

Workshop Manual Audi TT 2007 ➤

4-cylinder direct petrol injection engine (2.0 ltr. 4-valve turbo), mechanics

Engine ID	BWA	BPY							
-----------	-----	-----	--	--	--	--	--	--	--

Edition 11.2006

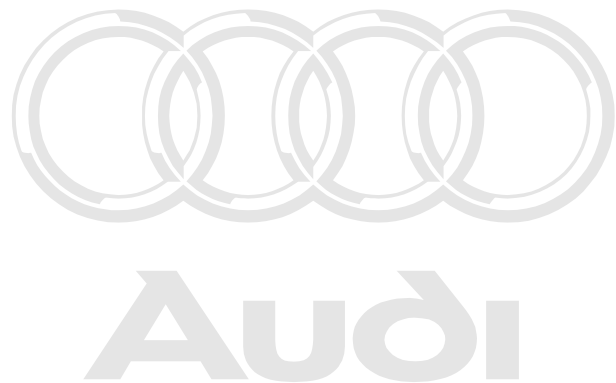

Protected by copyright. Copying for private or commercial purposes, in part or in whole, is not permitted unless authorised by AUDI AG. AUDI AG does not guarantee or accept any liability with respect to the correctness of information in this document. Copyright by AUDI AG.

List of Workshop Manual Repair Groups

Repair Group

- 00 - Technical data
- 10 - Removing and installing engine
- 13 - Crankshaft group
- 15 - Cylinder head, valve gear
- 17 - Lubrication
- 19 - Cooling
- 21 - Turbocharging/supercharging
- 26 - Exhaust system



Technical information should always be available to the foremen and mechanics, because their careful and constant adherence to the instructions is essential to ensure vehicle road-worthiness and safety. In addition, the normal basic safety precautions for working on motor vehicles must, as a matter of course, be observed.

Copyright by Audi AG. Audi AG does not guarantee or accept any liability with respect to the correctness of information in this document. Copyright by Audi AG.

All rights reserved.
No reproduction without prior agreement from publisher.

Contents

00 - Technical data	1
1 Engine number	1
2 Engine data	2
3 Safety precautions	3
4 Rules for cleanliness	4
10 - Removing and installing engine	5
1 Removing and installing engine, detaching from gearbox	5
1.1 Removing engine	5
1.2 Separating engine and gearbox	18
1.3 Securing engine to assembly stand	20
1.4 Installing engine	21
2 Assembly mountings	25
2.1 Assembly mountings - exploded view	25
2.2 Checking adjustment of assembly mountings (engine/gearbox mountings)	26
2.3 Adjusting assembly mountings	27
13 - Crankshaft group	32
1 Cylinder block (pulley end)	32
1.1 Poly V-belt, bracket for ancillaries - exploded view	32
1.2 Removing and installing poly V-belt	33
1.3 Removing and installing bracket for ancillaries	35
1.4 Removing and installing vibration damper	38
1.5 Front sealing flange - exploded view	40
1.6 Renewing crankshaft oil seal - pulley end	41
1.7 Removing and installing sealing flange (front)	44
2 Cylinder block (gearbox end)	48
2.1 Rear sealing flange and dual-mass flywheel - exploded view	48
2.2 Removing and installing dual-mass flywheel	49
2.3 Removing and installing sealing flange (rear)	50
3 Crankshaft	53
3.1 Crankshaft - exploded view	53
3.2 Crankshaft dimensions	55
3.3 Measuring axial clearance of crankshaft	55
3.4 Measuring radial clearance of crankshaft	56
3.5 Extracting and driving in needle bearing for crankshaft	57
3.6 Removing and installing chain sprocket	58
4 Pistons and conrods - exploded view	60
4.1 Piston and cylinder dimensions	62
15 - Cylinder head, valve gear	63
1 Toothed belt drive	63
1.1 Toothed belt drive - exploded view	63
1.2 Removing and installing toothed belt	66
2 Cylinder head	77
2.1 Cylinder head - exploded view	77
2.2 Removing and installing inlet camshaft control valve 1 N205	80
2.3 Removing and installing cylinder head cover	82
2.4 Removing and installing cylinder head	85
2.5 Checking compression	95
3 Valve gear	98



3.1	Valve gear - exploded view	98
3.2	Removing and installing camshaft adjuster	101
3.3	Removing and installing camshafts	103
3.4	Checking axial clearance of camshafts	107
3.5	Renewing valve stem oil seals	108
3.6	Checking valve guides	112
3.7	Renewing exhaust camshaft oil seal	114
17	- Lubrication	119
1	Oil pump and sump	119
1.1	Sump - exploded view	119
1.2	Removing and installing sump	120
1.3	Balance shaft assembly with oil pump - exploded view	125
1.4	Removing and installing balance shaft assembly with oil pump	127
2	Oil filter bracket and oil cooler	132
2.1	Oil filter bracket - exploded view	132
2.2	Draining oil filter housing	133
2.3	Removing and installing oil cooler	134
2.4	Removing and installing oil filter bracket	137
2.5	Checking oil pressure and oil pressure switch	141
19	- Cooling	143
1	Removing and installing parts of cooling system	143
1.1	Cooling system components (on engine) - exploded view	144
1.2	Continued coolant circulation pump V51 - exploded view	145
1.3	Diagram of coolant hose connections	146
1.4	Draining and filling cooling system	147
1.5	Checking cooling system for leaks	151
1.6	Removing and installing coolant pipes	152
1.7	Removing and installing coolant distributor housing with map-controlled engine cooling thermostat F265	155
1.8	Removing and installing coolant pump	155
1.9	Radiator and radiator fans - exploded view	158
1.10	Removing and installing radiator	158
1.11	Removing and installing radiator cowl	161
1.12	Removing and installing radiator fan V7 and radiator fan 2 V177	163
21	- Turbocharging/supercharging	164
1	Turbocharger	164
1.1	Fitting hose connections with plug-in connectors	164
1.2	Turbocharger - exploded view	165
1.3	Removing and installing turbocharger	170
1.4	Checking vacuum unit for turbocharger	177
1.5	Removing and installing vacuum unit for turbocharger	179
1.6	Adjusting vacuum unit for turbocharger	179
2	Charge air system	185
2.1	Charge air cooler - exploded view of components	185
2.2	Turbocharging diagram	186
2.3	Removing and installing charge air cooler	186
2.4	Checking charge air system for leaks	187
26	- Exhaust system	190
1	Parts of exhaust system	190
1.1	Exhaust system - exploded view	190
1.2	Removing and installing front exhaust pipe with catalytic converters and front silencer	191
1.3	Aligning exhaust system	194

1.4 Checking exhaust system for leaks 195

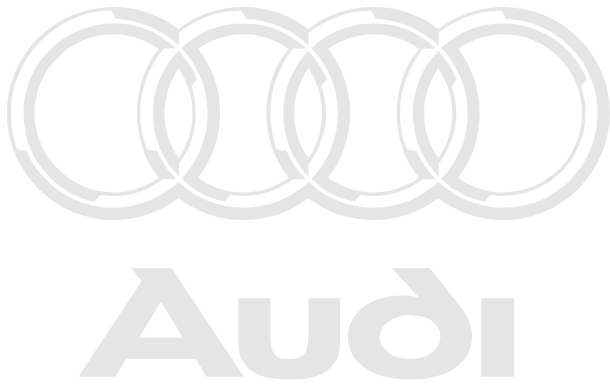

Protected by copyright. Copying for private or commercial purposes, in part or in whole, is not permitted unless authorised by AUDI AG. AUDI AG does not guarantee or accept any liability with respect to the correctness of information in this document. Copyright by AUDI AG.



Audi

Protected by copyright. Copying for private or commercial purposes, in part or in whole, is not permitted unless authorised by AUDI AG. AUDI AG does not guarantee or accept any liability with respect to the correctness of information in this document. Copyright by AUDI AG.

00 – Technical data

1 Engine number

The engine number (including “Engine code” and “Serial number”) can be found on the left of the joint between engine and gearbox.

The engine code is also stamped on the right of the cylinder head and on the cylinder block.

The engine number consists of up to nine characters (alphanumeric). The first part (up to 3 code letters) represents the “engine code letters”, the second part (6 digits) the “serial number”. If more than 999 999 engines were produced with the same code letters, the first of the 6 digits is replaced by a letter.

Additionally there is a sticker on the toothed belt cover showing the “engine code” and “serial number”.

The engine code is also to be found on the vehicle data sticker.

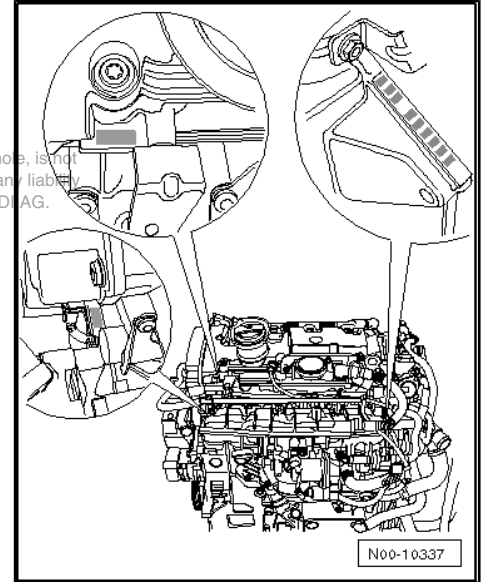



2 Engine data

Code letters		BWA	BPY
Capacity	ltr.	1.984	1.984
Power output	kW at rpm	147/5100	147/5700
Torque	Nm at rpm	280/1800	280/2000
Bore	∅ in mm	82.5	82.5
Stroke	mm	92.8	92.8
Compression ratio		10.3	10.5
RON		98 ¹⁾	98 ¹⁾
Injection/ignition system		FSI	FSI
Firing order		1-3-4-2	1-3-4-2
Knock control		yes	yes
Turbocharging/supercharging		yes	yes
Exhaust gas recirculation		no	no
Intake manifold change-over		no	no
Variable valve timing		yes	yes
Secondary air system		no	no

• ¹⁾ Unleaded petrol RON 95 can also be used, but results in reduced power



Audi

Protected by copyright. Copying for private or commercial purposes, in part or in whole, is not permitted unless authorised by AUDI AG. AUDI AG does not guarantee or accept any liability with respect to the correctness of information in this document. Copyright by AUDI AG.

3 Safety precautions

When working on the fuel system please note the following warnings:



WARNING

The fuel system is pressurised. Before opening the system place a clean cloth around the connection. Then release pressure by carefully loosening the connection.

Observe the following to avoid injuries to persons and/or damage to the injection and ignition system:

- ◆ Always switch off the ignition before connecting or disconnecting electrical wiring for the injection or ignition system or tester cables.
- ◆ Certain tests may lead to a fault being detected by the engine control unit and stored in the memory. You must therefore interrogate the fault memory and erase it if necessary after completion of all tests and repair work. If you erase the fault memory, you must then generate the readiness code in the engine control unit in "Guided Fault Finding" mode ⇒ Vehicle diagnosis, testing and information system VAS 5051.
- ◆ Always switch off the ignition before cleaning the engine.



Caution

- ◆ *Observe notes on procedure for disconnecting the battery ⇒ Rep. Gr. 27.*
- ◆ *Always switch off the ignition before connecting or disconnecting the battery, otherwise the engine control unit may be damaged.*

When working on the cooling system note the following warnings:



WARNING

Hot steam or hot coolant can escape when expansion tank is opened; cover filler cap with cloth and open carefully.

Note the following if testers and measuring instruments have to be used during a road test:



WARNING

- ◆ *Test equipment must always be secured on the rear seat and operated from that position by a second person.*
- ◆ *If test and measuring instruments are operated from front passenger's seat and the vehicle is involved in an accident, the person sitting in this seat could be seriously injured when the airbag is triggered.*



4 Rules for cleanliness

Injection system/fuel system

Even small amounts of dirt can cause faults in the injection system. When working on the fuel supply/injection system, please pay careful attention to the following basic rules:

- ◆ Carefully clean connection points and the surrounding area with engine cleaner or brake cleaner and dry thoroughly before opening.
- ◆ Plug open lines and connections with suitable protective caps immediately.
- ◆ Place parts that have been removed on a clean surface and cover them over. Use only lint-free cloths.
- ◆ Only install clean components; replacement parts should only be unpacked immediately prior to installation. Do not use parts that have been previously unpacked and stored away loose (e.g. in toolboxes, etc.).
- ◆ When the system is open: Do not work with compressed air. Do not move the vehicle unless absolutely necessary.
- ◆ Unplugged electrical connectors must be kept clean and dry. Make sure connections are dry when attaching.

Turbocharger

When working on the turbocharger, pay careful attention to the following "5 rules":

- ◆ Thoroughly clean all unions and surrounding areas before disconnecting.
- ◆ Place parts that have been removed on a clean surface and cover them over. Use only lint-free cloths.
- ◆ Carefully cover or seal open components if repairs cannot be carried out immediately.
- ◆ Only install clean components; replacement parts should only be unpacked immediately prior to installation. Do not use parts that have been stored loose (e.g. in tool boxes etc.).
- ◆ When the system is open: Do not work with compressed air if this can be avoided. Do not move the vehicle unless absolutely necessary.

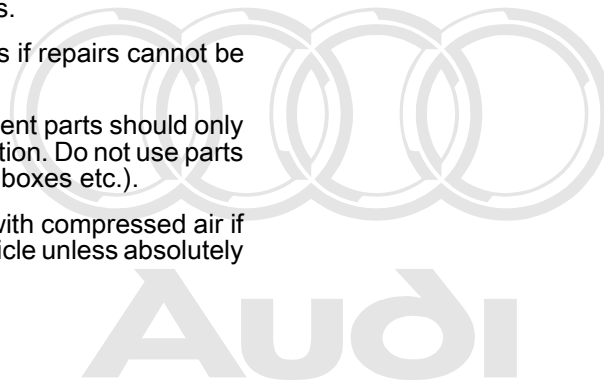

Protected by copyright. Copying for private or commercial purposes, in part or in whole, is not permitted unless authorised by AUDI AG. AUDI AG does not guarantee or accept any liability with respect to the correctness of information in this document. Copyright by AUDI AG.

10 – Removing and installing engine

1 Removing and installing engine, detaching from gearbox

1.1 Removing engine

Special tools and workshop equipment required

- ◆ Drip tray for workshop hoist -VAS 6208-
- ◆ Engine and gearbox jack - V.A.G 1383 A-
- ◆ Hose clip pliers -V.A.G 1921-
- ◆ Stepladder -VAS 5085-
- ◆ Engine bracket -T10012-
- ◆ Removal lever -80 - 200-

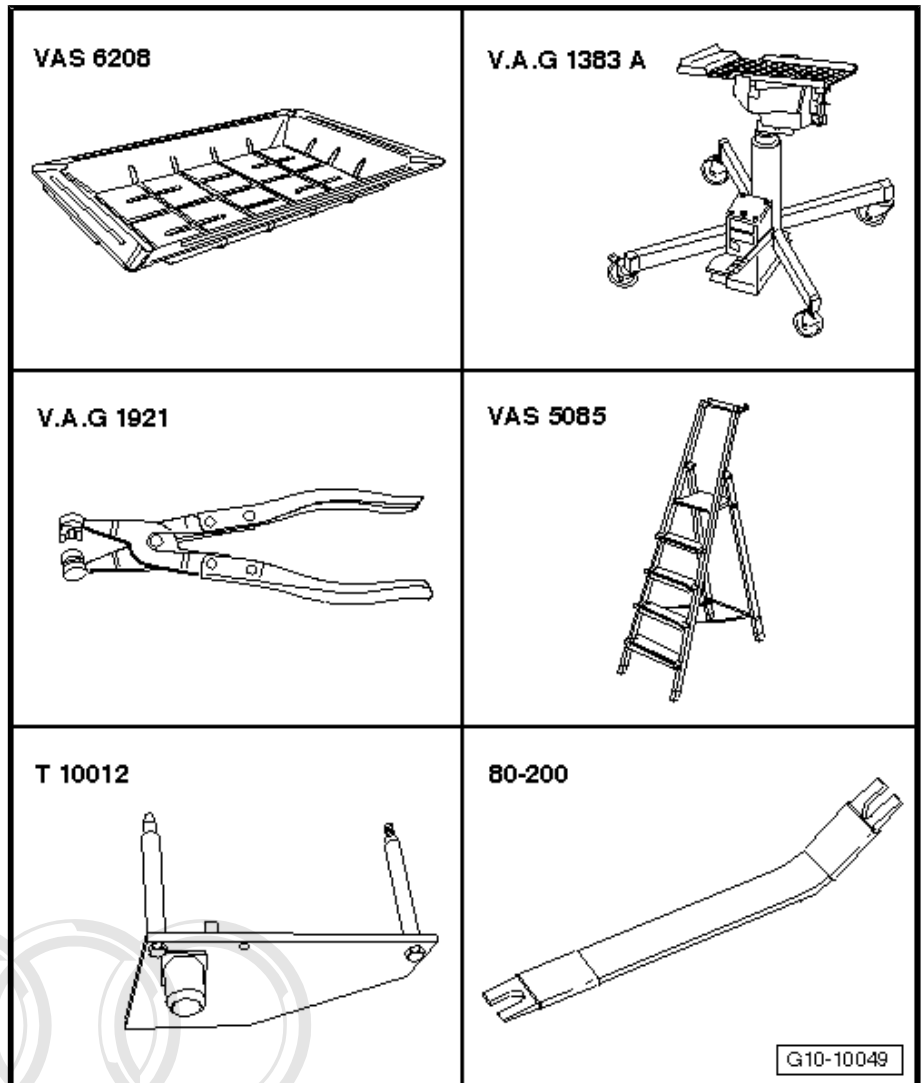



Lambda probe open ring spanner set -3337-

Engine bung set -VAS 6122-



Note

- ◆ *The engine is removed from underneath together with the gearbox.*
- ◆ *Renew all cable ties which are released or cut open when removing the engine. Refit in the same position when installing the engine.*
- ◆ *Heat insulation sleeves removed when taking out the engine are to be reinstalled in the original position.*
- ◆ *Collect drained coolant in a clean container for re-use or disposal.*

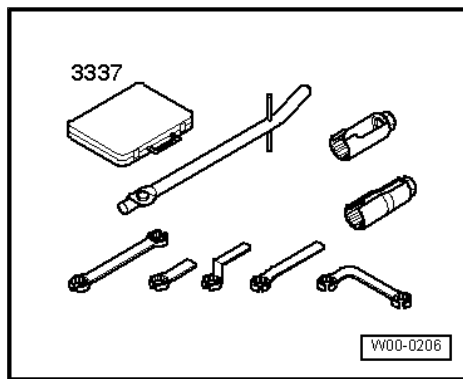

VW00-0206



WARNING

Observe notes on procedure for disconnecting the battery. => Electrical system; Rep. Gr. 27

- Remove luggage compartment floor covering.
- Release retaining clips -arrows- and detach cover for negative terminal.



Note

Remove rear cross panel trim if cover for negative terminal of battery is located under rear cross panel trim => Rep. Gr. 70 .

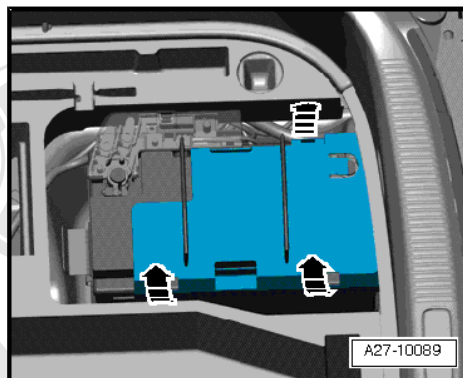

A27-10089

- With ignition switched off, disconnect earth wire -arrow- at battery.

Protected by copyright. Copying for private or commercial purposes is not permitted unless authorised by AUDI AG. AUDI AG does not guarantee with respect to the correctness of information in this document.



WARNING

Hot steam/hot coolant may escape when opening expansion tank. Cover cap with cloth and open carefully.

- Open filler cap on coolant expansion tank
- Remove both front wheels.

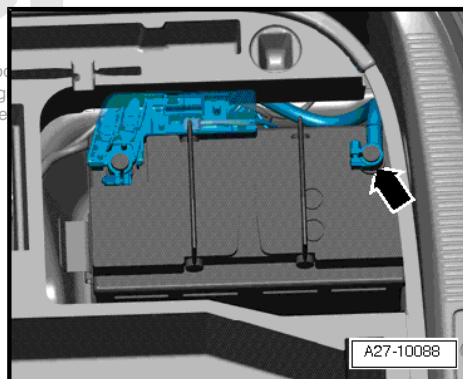

A27-10088

- Remove centre noise insulation -fasteners 1 ... 4-

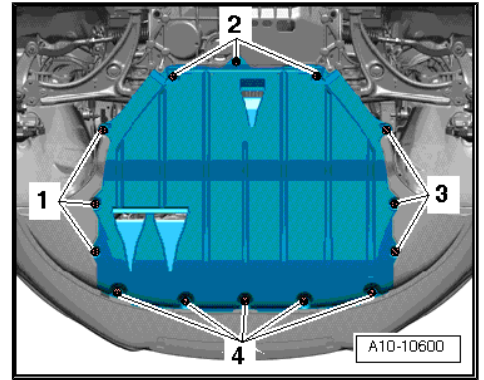

- Remove noise insulation panels (left and right) -arrows-

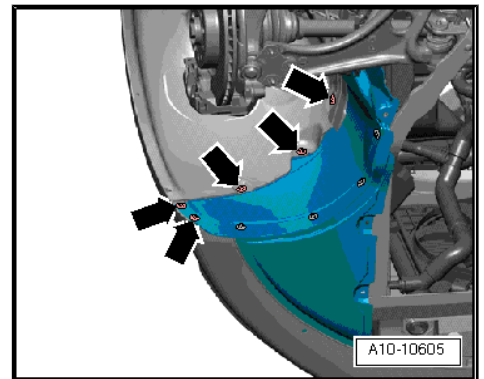

- Remove noise insulation frame -arrow-

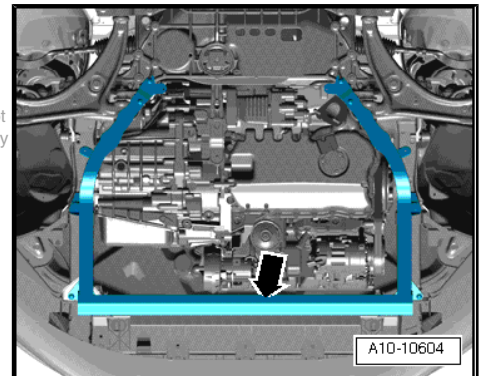

Protected by copyright. Copying for private or commercial purposes, in part or in whole, is not permitted unless authorised by AUDI AG. AUDI AG does not guarantee or accept any liability with respect to the correctness of information in this document. Copyright by AUDI AG.

- Unplug electrical connector at air mass meter -G70- -3-
- Open clamps -1 and 2- and disconnect air intake hose from air mass meter.
- Detach air intake connection at lock carrier -4-
- Pull off engine cover panel.

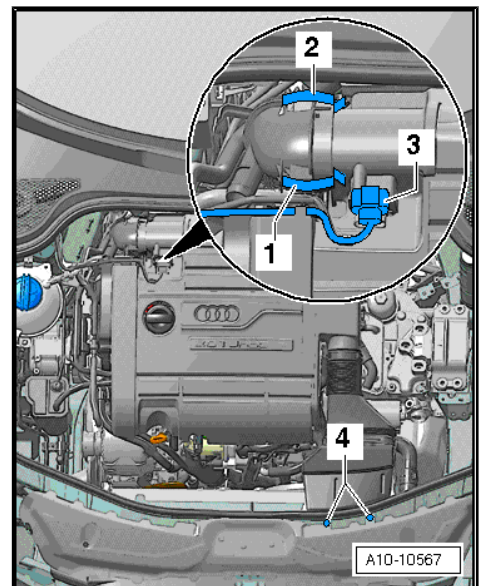



- Remove air intake hose -arrow- using hose clip pliers -V.A.G 1921- .

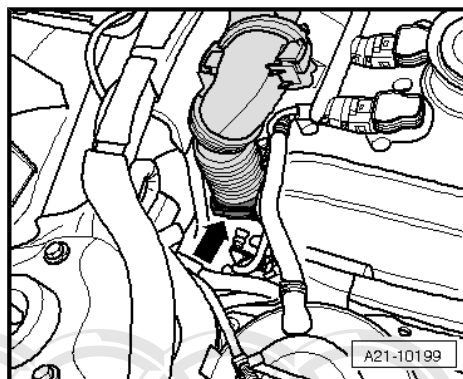

- Remove electrical connector -arrow- for Lambda probe (before catalytic converter) from bracket, unplug and move clear.

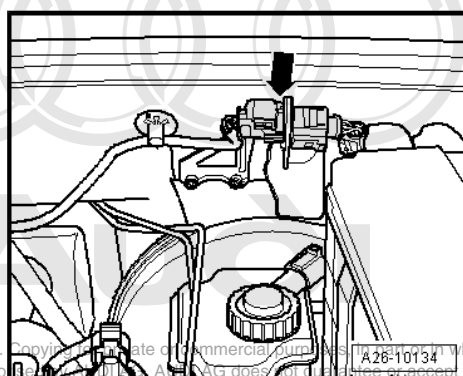

Protected by copyright. Copying for private or commercial purposes without the written permission of Audi AG is prohibited. Audi AG does not accept any liability with respect to the correctness of information in this document. Copyright by AUDI AG.

- Unscrew Lambda probe -G39- -arrow- using tool from Lambda probe open ring spanner set -3337- .
- Use screwdriver to pry off cover caps on wiper arms and unscrew hexagon nuts.
- Pull wiper arms off wiper shafts and remove.

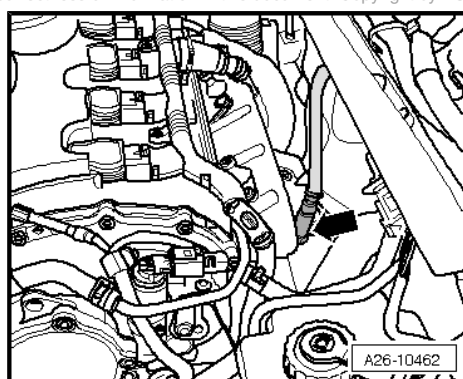

- Pull off rubber seal -1- on plenum chamber cover.
- Detach plenum chamber cover -2-.
- Move engine wiring harness in plenum chamber clear.
- Remove engine control unit. => Rep. Gr. 24

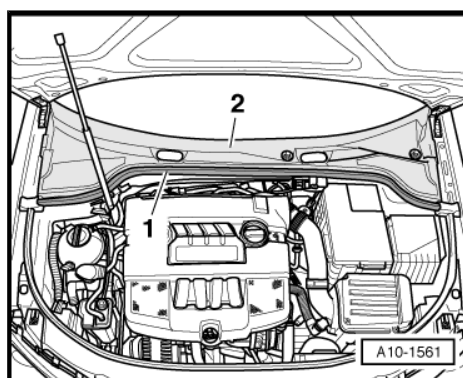

- Unplug engine wiring harness connector -1-.

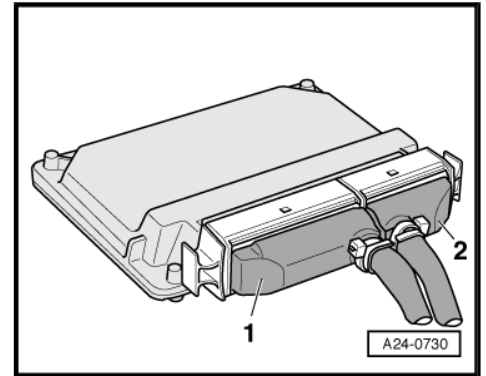

- Release wiring protector for engine wiring harness -arrow- and lift off.

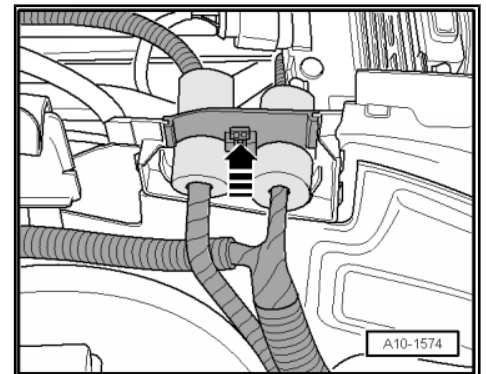

- Open wiring duct brackets -arrows-.

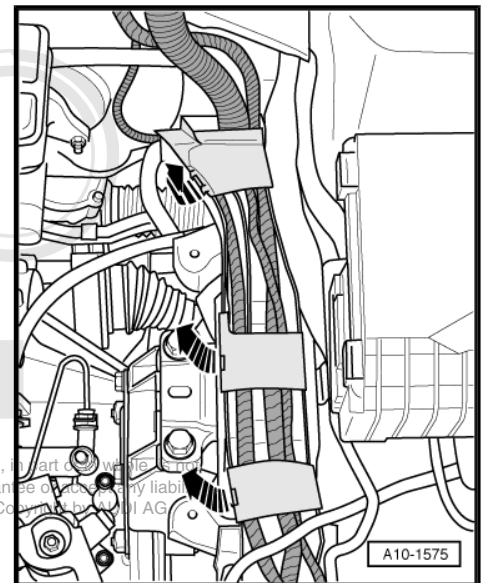

- Move electrical connector -1- clear and unplug connector.
- Open wiring duct bracket located below -2-.
- Open wiring duct bracket -3-.
- Remove engine control unit wiring harness from wiring duct.

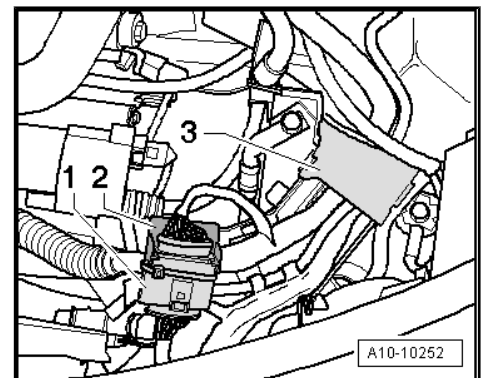

Protected by copyright. Copying for private or commercial purposes, in part or whole, is not permitted unless authorised by AUDI AG. AUDI AG does not guarantee of any liability with respect to the correctness of information in this document. Copyright © AUDI AG

**Note**

Use removal lever -80 - 200- to lever out the wiring clips.

- Unplug electrical connector -1- for reversing light switch.
- Disconnect earth cable -2-.
- Unplug electrical connector -3-.
- Slide cover -4- to rear.

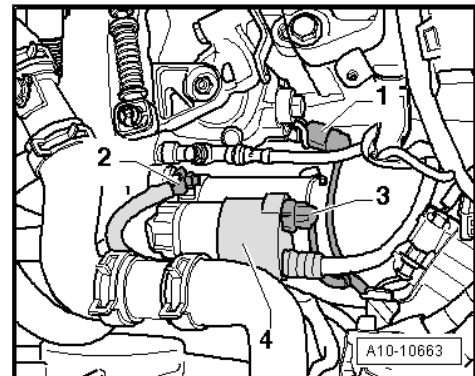
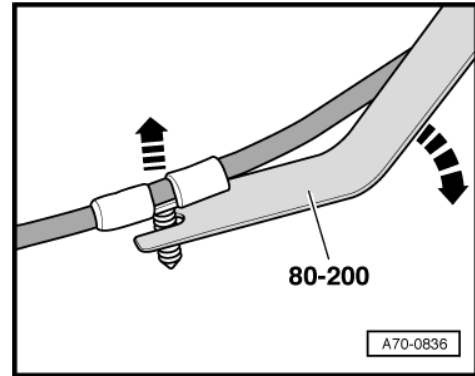

- Detach wire -arrow- at starter and move clear.

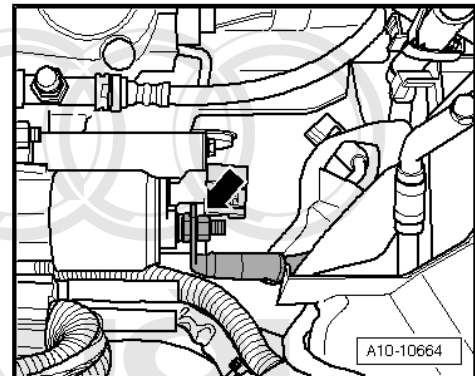

- Press the two clips in direction of the -arrows- and remove cover from electronics box in engine compartment.

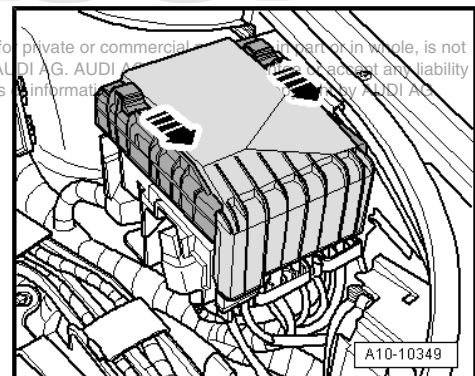

Copyright © 2006 Audi AG. All rights reserved. Copying for private or commercial use, in part or in whole, is not permitted unless authorised by AUDI AG. AUDI AG does not accept any liability with respect to the correctness of information provided by AUDI AG.

- Unscrew electrical wire -1- and move clear up to engine.
- Unplug electrical connector -2-.

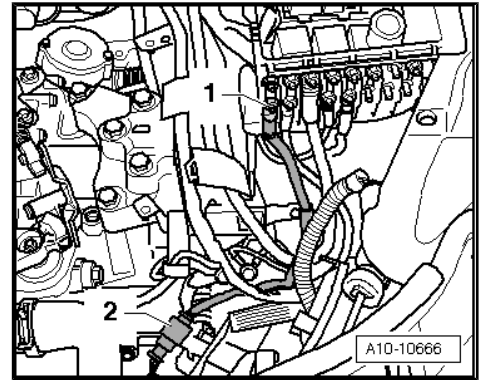

- Unscrew bolts -1- from above.

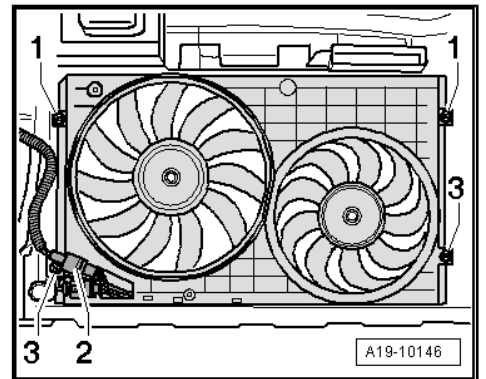

- Place drip tray for workshop hoist -VAS 6208- beneath engine.
- To drain off coolant, detach bottom coolant hose -arrow-.

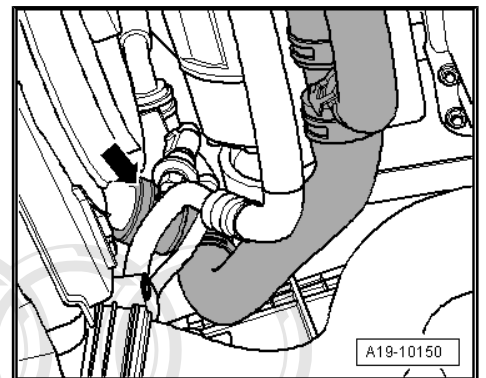

- Remove air pipe -1 and 2- for charge air cooler.

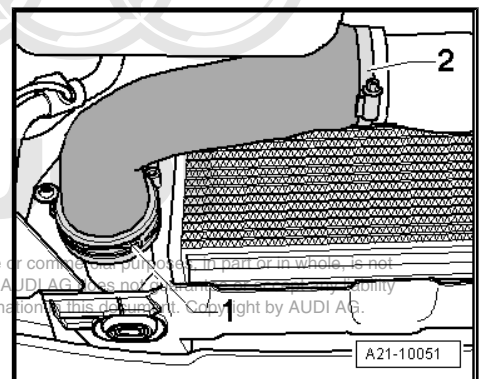

Protected by copyright. Copying for private or confidential purposes, in part or in whole, is not permitted unless authorised by AUDI AG. AUDI AG does not accept any liability with respect to the correctness of information in this document. Copyright by AUDI AG.



- Unplug electrical connector -2-.
- Unscrew the bolts -3- and remove radiator cowl from below.

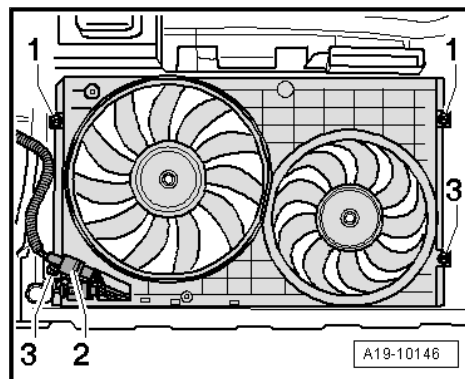

- Detach top coolant hose from radiator -arrow-.

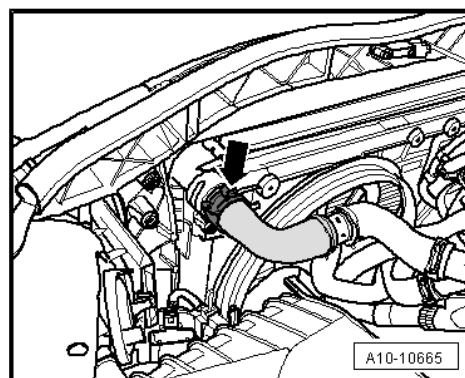

- Detach coolant hoses going to heat exchanger -arrows-.

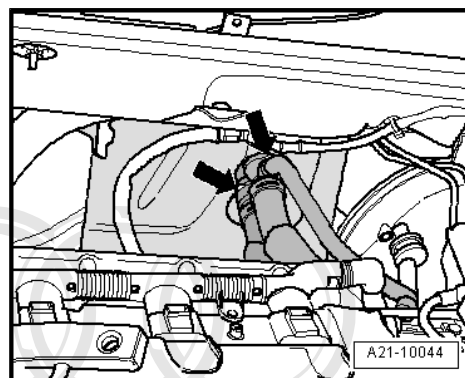

- Unscrew securing bolts -arrows- for front exhaust pipe/turbo-charger accessible from above.

i Note

Shown in illustration from rear with engine removed.

Protected by copyright. Copying for private use is permitted unless authorised by AUDI AG. No liability with respect to the correctness of illustrations.

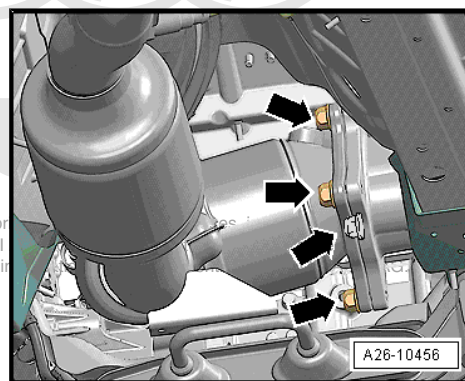

- Disconnect vacuum hose -arrow- leading to brake servo.

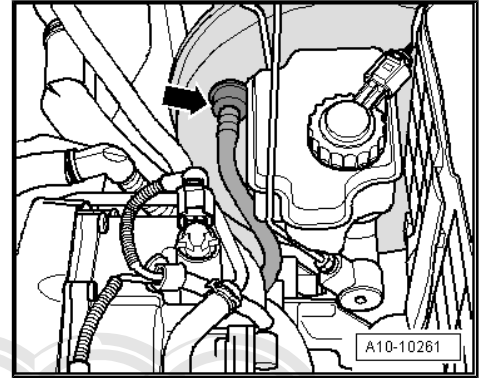

- Unclip securing clips -1- and -2- on both selector cables.
- Pull off selector cable end-pieces from gearbox selector lever and relay lever.
- Detach cable support bracket from gearbox -arrows- and place to one side.

**WARNING**

Do not press clutch pedal after disconnecting hose leading to slave cylinder.

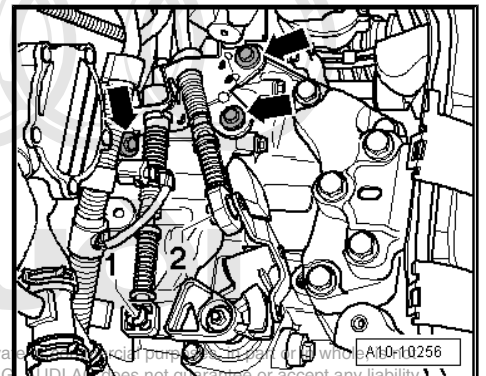

- Pull out clip -2- as far a stop in -direction of arrow- and detach hose -1-.

**WARNING**

Fuel supply line is pressurised. Wear safety goggles and protective clothing to avoid possible injury and skin contact. Before removing from hose connection wrap a cloth around the connection. Then release pressure by carefully pulling hose off connection.

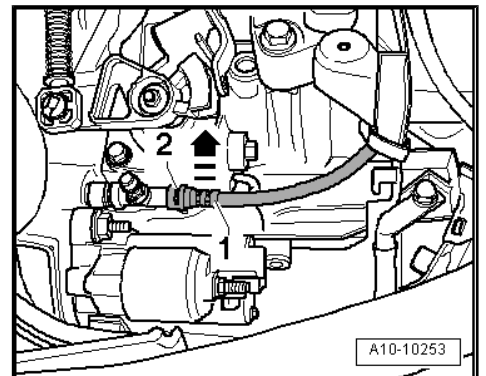

- Mark fuel line -2- and line going to ACF -1-.
- Disconnect fuel line -2- and move clear.
- Disconnect ACF line -1- and move clear.
- Disconnect vacuum line -3- going to activated charcoal filter (press release tabs).
- Lift out ACF.

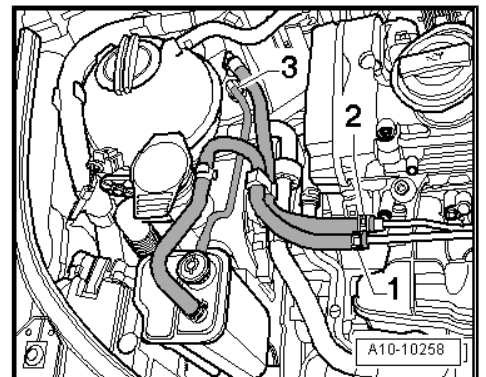



- Detach coolant hoses -1 and 2-.
- Discharge the refrigerant system => Rep. Gr. 87 ; Air conditioner system with refrigerant R134a .

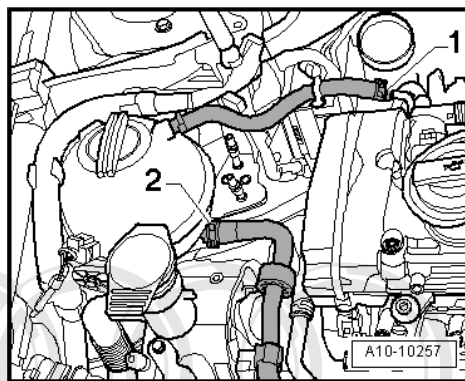

- Disconnect air conditioner pipes -arrows- at compressor.
- Plug the openings with sealing plugs from engine bung set -VAS 6122- .

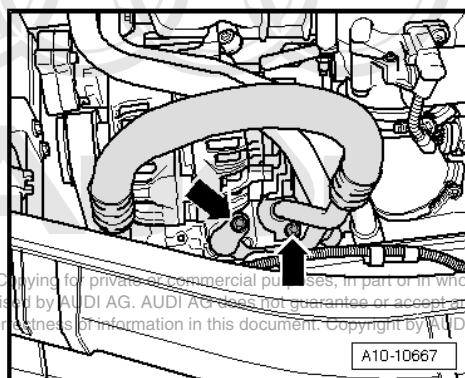

Protected by copyright. Copying for private or commercial purposes, in part or in whole, is not permitted unless authorized by AUDI AG. AUDI AG does not guarantee or accept any liability with respect to the correctness of information in this document. Copyright by AUDI AG.

- Loosen bolts -arrows- of assembly mounting for engine approx. 2 turns.

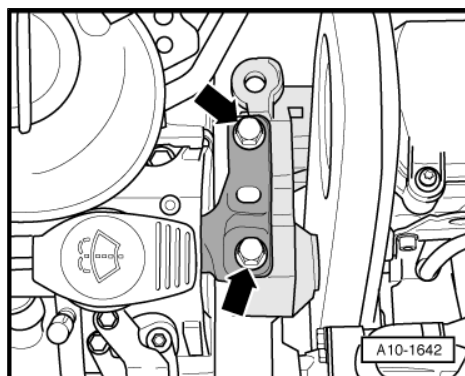

- Loosen bolts -arrows- of assembly mounting for gearbox approx. 2 turns.

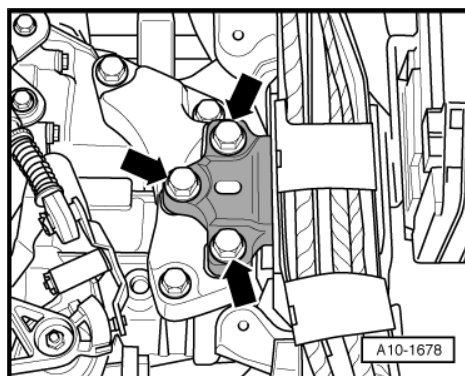

- Unplug electrical connector -arrow-.

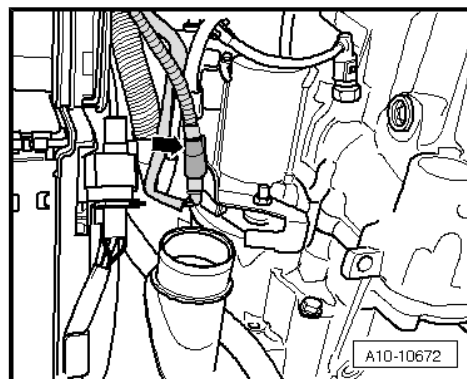

- Remove air pipe -arrows-.

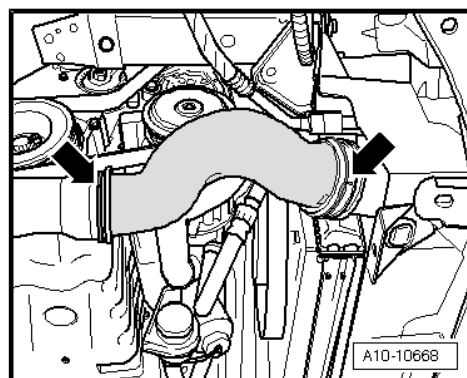

- Unplug electrical connector -1- for high-pressure sender - G65- .
- Detach air conditioner pipe from condenser -2-.

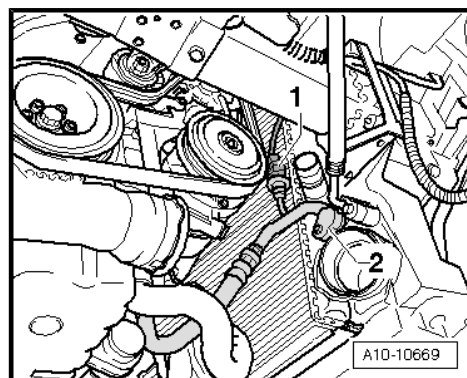

- Unplug electrical connector at oil level sender -1-.
- Unclip bracket -2-.

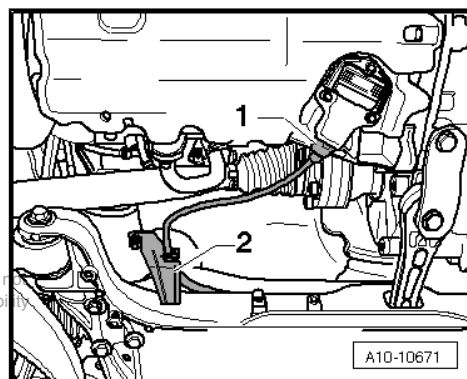

Protected by copyright. Copying for private or commercial purposes, in part or in whole, is not permitted unless authorised by AUDI AG. AUDI AG does not guarantee or accept any liability with respect to the correctness of information in this document. Copyright by AUDI AG.



- Unbolt heat shield for drive shaft (right-side) -arrows-.
- Remove drive shafts (left and right) => Rep. Gr. 40 .

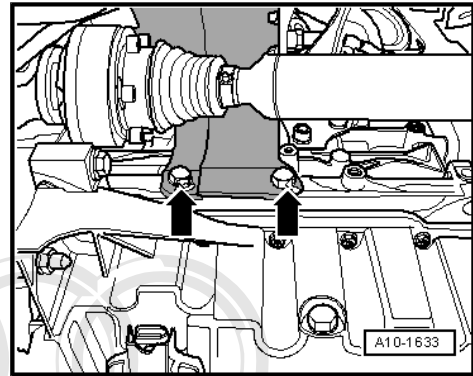

- Remove nuts -1- and -2- on bracket for electrical connector for Lambda probe on underside of vehicle and remove cover.
- Unscrew bolt -3- and move electrical wire for Lambda probe clear.

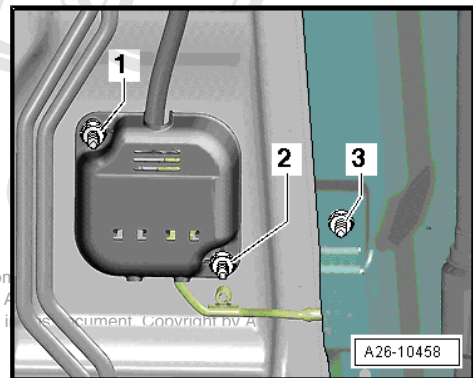

- Detach plug connector from bracket -arrow-.
- Unplug connector for Lambda probe after catalytic converter -G130- .

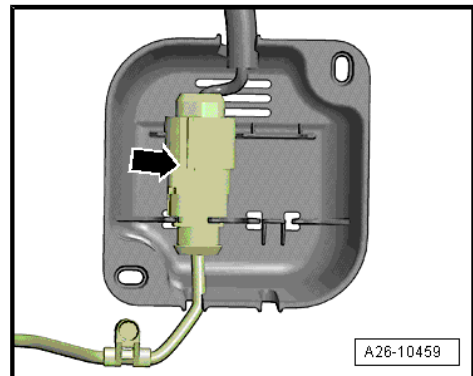

- Unscrew remaining securing nuts -arrows- for front exhaust pipe/turbocharger from below.

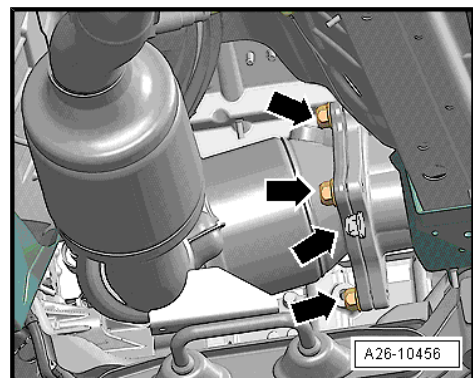

Protected by copyright. Copying for private or commercial use is not permitted unless authorised by AUDI AG. AUDI AG is not responsible with respect to the correctness of information in this document. Copyright by Audi AG.

- Unbolt bracket for exhaust system and tunnel brace -arrows-.

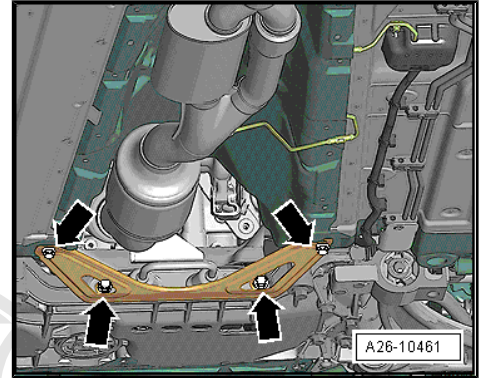

 Note

To avoid any damage, the flexible joint in the front exhaust pipe must not be bent more than 10°.

- Separate exhaust system at clamp -arrows-.
- Remove front exhaust pipe with catalytic converter and front silencer.

Protected by copyright. Copying for private or commercial purposes is not permitted unless authorised by AUDI AG. AUDI AG does not accept any liability with respect to the correctness of information in this document.

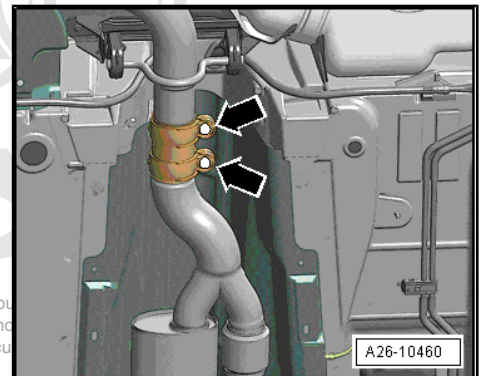

- Remove bolts -1 ... 3- and take out pendulum support.

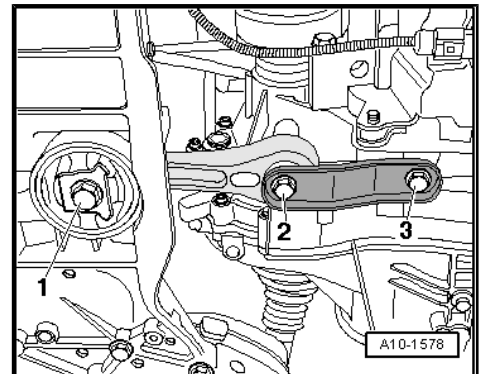

- Unscrew the additional coolant pump -arrows-.

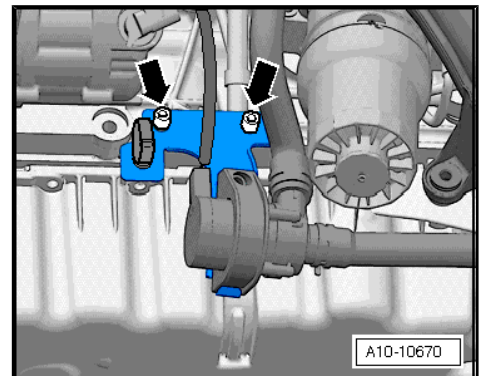



- Bolt engine bracket -T10012- with securing bolt -1- and nut -2- to cylinder block (tightening torque: approx. 20 Nm).
- Insert engine and gearbox jack -V.A.G 1383 A- in engine bracket -T10012- and raise engine slightly.



Note

To unscrew bolts for assembly mounting use stepladder -VAS 5085- .

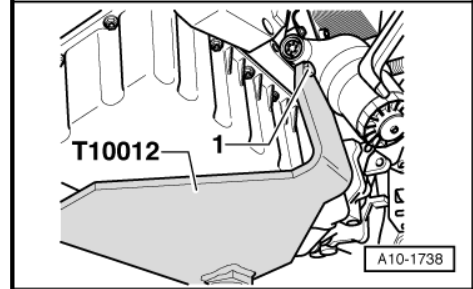
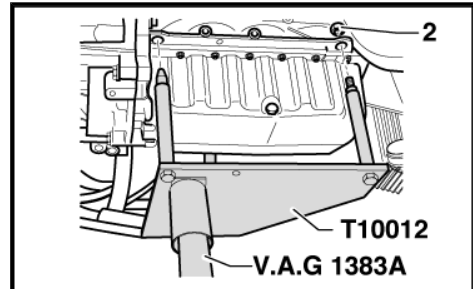

- Remove bolts -arrows- of assembly mounting on engine.

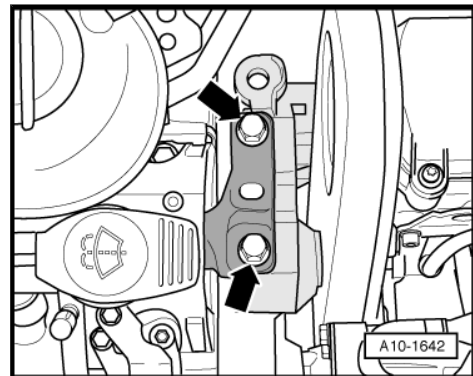

- Remove bolts -arrows- of assembly mounting for gearbox.



Note

- ◆ Check that all hoses, pipes and wiring connections between engine, gearbox and body have been detached.
- ◆ Carefully guide engine/gearbox assembly when lowering to avoid damage.

- Pull engine/gearbox assembly as far forward as possible, and lower gradually.

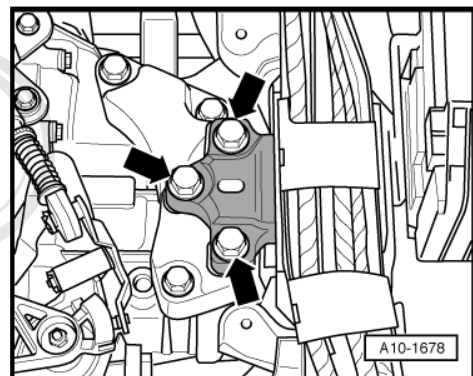

1.2 Separating engine and gearbox

- Engine/gearbox assembly removed and attached to engine bracket -T10012- with respect to the correctness of information in this document. Copyright by AUDI AG.

- Unscrew bolt -1- with gearbox installed.
- Pull up cover plate -2- and remove.

 **Note**

Shown in illustration with gearbox removed.

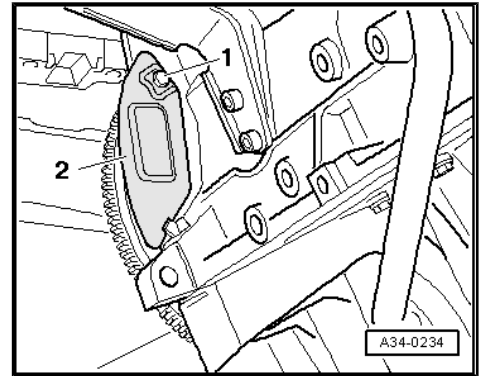

- Remove bolts -1 ... 8- on engine/gearbox flange.
- Detach starter.

 **Note**

The manual gearbox can be detached from the engine without a workshop hoist, a 2nd mechanic is required for this purpose.

- Separate gearbox from engine.

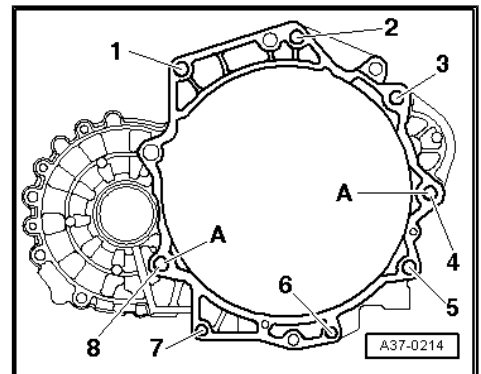

Protected by copyright. Copying for private or commercial purposes, in part or in whole, is not permitted unless authorised by AUDI AG. AUDI AG does not guarantee or accept any liability with respect to the correctness of information in this document. Copyright by AUDI AG.



1.3 Securing engine to assembly stand

Special tools and workshop equipment required

- ◆ Lifting tackle -2024 A-
- ◆ Workshop hoist -VAS 6100-
- ◆ Engine and gearbox support -VAS 6095-

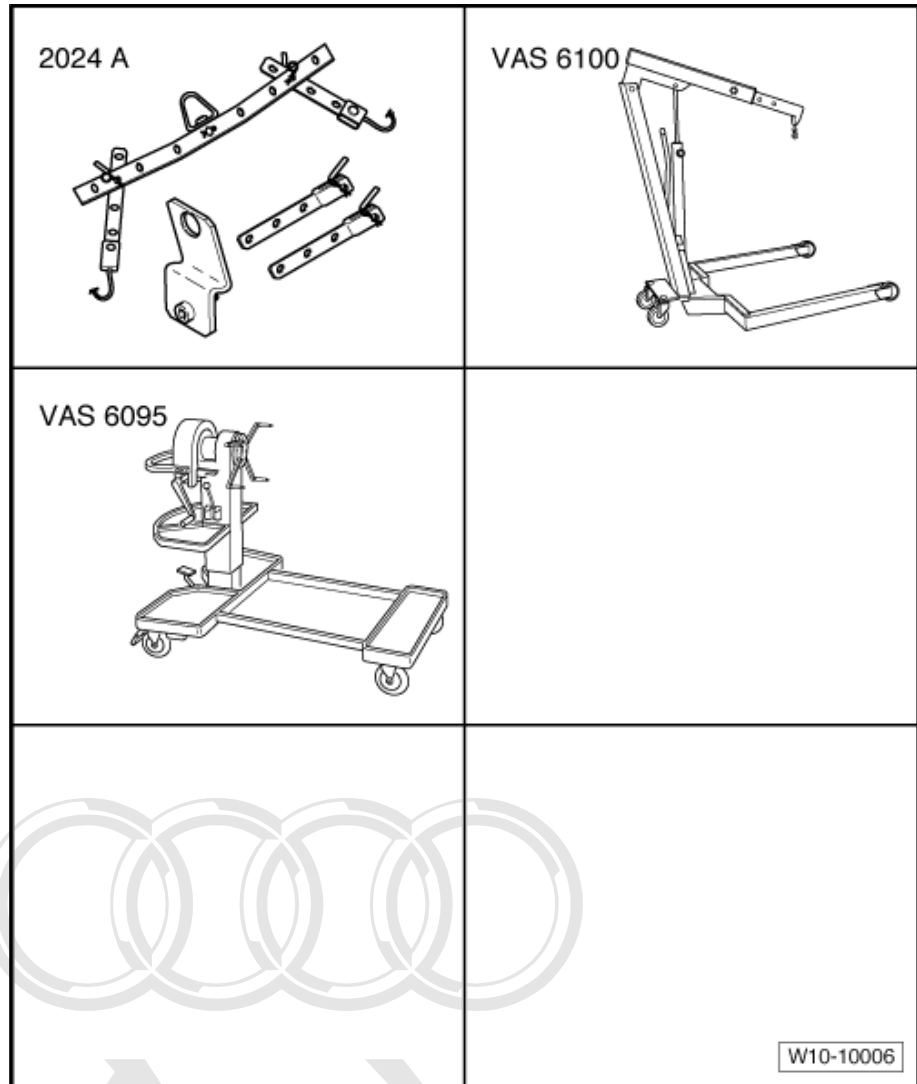

- Gearbox detached from engine.

Protected by copyright. Copying for private or commercial purposes, in part or in whole, is not permitted unless authorised by AUDI AG. AUDI AG does not guarantee or accept any liability with respect to the correctness of information in this document. Copyright by AUDI AG.

- Engage lifting tackle -2024 A- on engine and workshop hoist -VAS 6100- .

 **Note**

To adjust to the centre of gravity of the assembly, the perforated rails of the support hooks must be positioned as shown.



WARNING

The support hooks and locating pins on the lifting tackle must be secured with locking pins (arrows in illustration).

- Lift engine off engine bracket -T10012- using workshop hoist -VAS 6100- .

Secure engine to engine and gearbox support -VAS 6095- when dismantling/assembling engine.

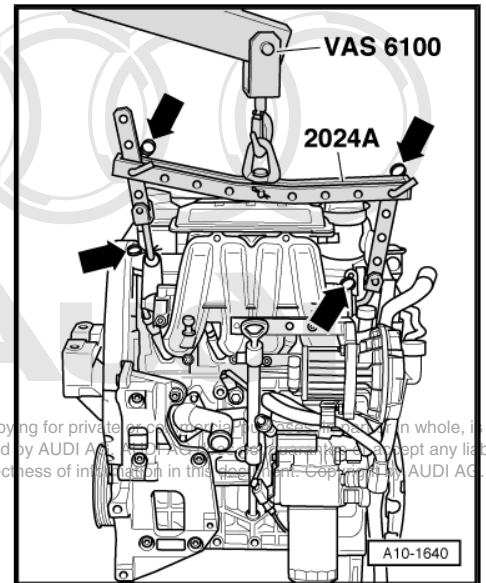

1.4 Installing engine

- Engine installed on engine bracket -T10012- .

Installation is carried out in the reverse order; note the following:

 **Note**

- ◆ *Reinstall all cable ties in the same locations when assembling.*
 - ◆ *Secure all hose connections with the correct type of hose clips (same as original equipment): => Parts catalogue*
 - ◆ *Renew self-locking nuts and bolts when performing assembly work.*
 - ◆ *Renew bolts which are tightened to a specified angle as well as oil seals and gaskets.*
 - ◆ *Clean input shaft splines and (in the case of used clutch plates) the hub splines. Remove corrosion and apply only a very thin coating of grease (=> Parts catalogue) to the splines. Then move clutch plate back and forth on input shaft until the hub moves smoothly on the shaft. Remove any excess grease.*
- Check whether dowel sleeves for centring the engine/gearbox assembly are fitted in the cylinder block; install dowel sleeves if necessary.



- Ensure that the intermediate plate is engaged on the sealing flange and pushed onto the dowel sleeves -arrows-.
- Check clutch release bearing for wear; renew if necessary.
- Bolt gearbox to engine.

**Note**

- ◆ *Tightening torques apply only to lightly greased, oiled, phosphated or black-finished nuts and bolts.*
- ◆ *Additional lubricant such as engine oil or gearbox oil may be used, but do not use lubricant containing graphite.*
- ◆ *Do not use degreased parts.*
- ◆ *Tolerance for tightening torques: 15%.*

Securing engine to gearbox

Item	Bolt	Nm
1, 2	M12×65	80
3 1), 4 1)	M12×135	80
5 ... 7	M10×60	40
8	M12×90	65

• 1) Bolt with M8 stud

A: Centring sleeves

- Push in splash plate -2- in such a way that the lower lug engages into the cylinder block and secure on top with bolt -1-.

**Note**

Shown in illustration with gearbox removed.

- Guide engine/gearbox assembly into the body.
- Tighten bolts -arrows- of assembly mounting for engine initially hand-tight.

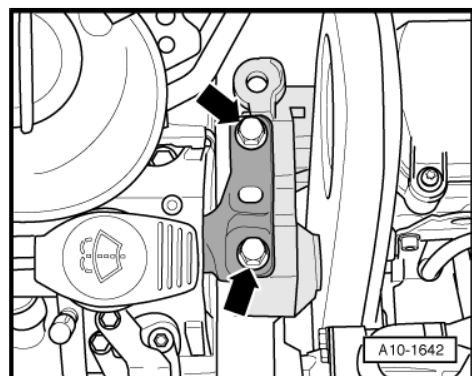
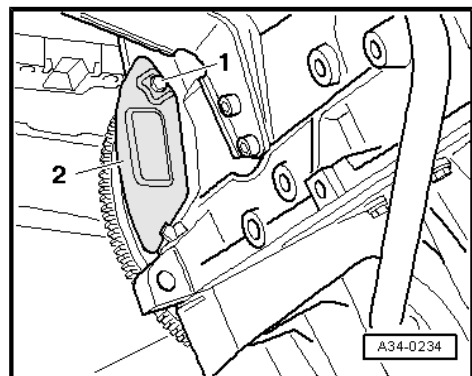
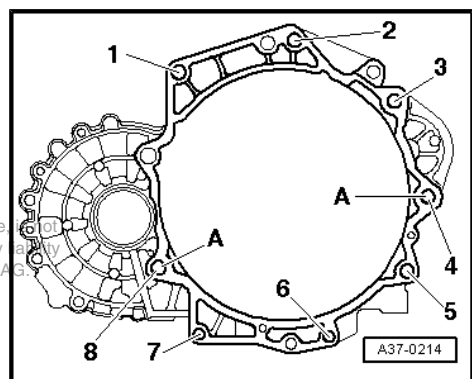
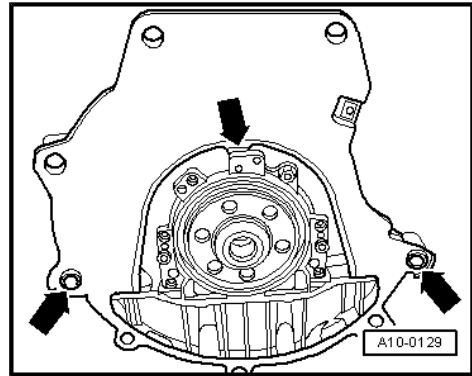

- Tighten bolts of assembly mounting for gearbox -arrows- initially hand-tight.

 Note

- ◆ Use new securing bolts.
- ◆ The bolts are tightened to final torque only after adjusting the engine mountings ⇒ [page 25](#).
- Remove engine bracket -T10012- from engine.

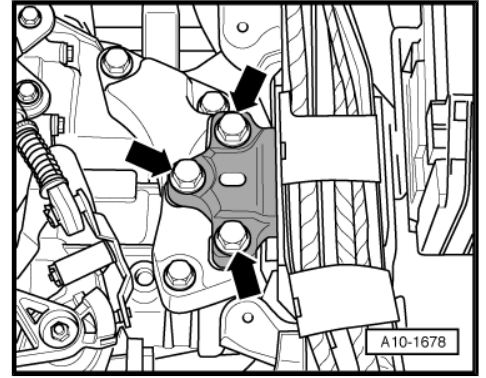

Protected by copyright. Copying for private or commercial purposes, in part or in whole, is not permitted unless authorised by AUDI AG. AUDI AG does not guarantee or accept any liability with respect to the correctness of information in this document. Copyright by AUDI AG.



- Secure pendulum support to gearbox and subframe -1 ... 3-
- Install drive shafts ⇒ Running gear, front-wheel drive and four-wheel drive; Repair group 40
- Install exhaust system and align it free of stress
⇒ [page 194](#) .
- Install Lambda probe -G39- ⇒ Rep. Gr. 24 .
- Charge refrigerant circuit ⇒ Air conditioning system; Repair group 87
- Attach and adjust selector mechanism at gearbox: ⇒ Rep. Gr. 34 .
- Adjust engine mountings ⇒ [page 27](#) .
- Electrical connections and routing: ⇒ Current flow diagrams, Electrical fault finding and Fitting locations
- Bleed fuel system ⇒ Motronic direct injection and ignition system (4-cylinder); Repair group 24; Servicing fuel injection system
- Check oil level ⇒ Maintenance ; Booklet 810 .
- Connect battery ⇒ Electrical system; Rep. Gr. 27 .
- Fill up with coolant ⇒ [page 147](#) .
- Installing air pipes with connectors ⇒ [page 164](#)

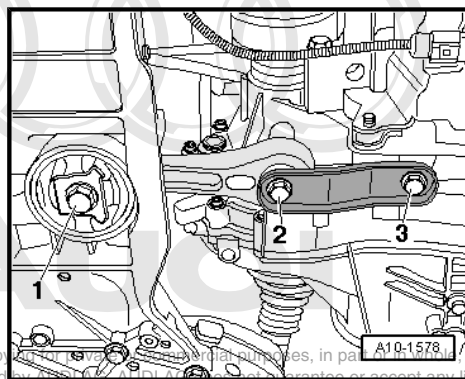

Protected by copyright. Copying or reproduction in any form is not permitted unless authorised in writing by Audi AG. The copyright holder is not liable with respect to the correctness of information in this document. Copyright by AUDI AG.

**Note**

- ◆ *Drained-off coolant may only be used again if the original cylinder head and cylinder block are re-installed.*
- ◆ *Contaminated or dirty coolant must not be used again.*

**WARNING**

Never use battery charging equipment for boost starting. There is danger of damaging the vehicle's control units.

Tightening torque

Component		Nm
Bolts/nuts	M6	10
	M8	20
	M10	45
	M12	65
Except for the following:		
Pendulum support to gearbox		40 + 90° 1)2)
Pendulum support to subframe		100 + 90° 1)2)
Terminal B+ to starter		16
Earth wire to gearbox		23
<ul style="list-style-type: none"> • 1) Renew bolt • 2) 90° = one quarter turn. 		

2 Assembly mountings

2.1 Assembly mountings - exploded view

1 - Bolt

- Gearbox support to gearbox
- Tightening torque => Rep. Gr. 34

2 - Bolts

- Pendulum support to gearbox
- Renew
- 40 Nm + 90° (1/4 turn further).

3 - Engine support

- With support arm

4 - Bolt

- Engine support to engine
- 45 Nm

5 - Engine mounting

6 - Bolt

- Engine mounting to body
- Renew
- 40 Nm + 90° (1/4 turn further).

7 - Connecting bracket

8 - Bolt

- Connecting bracket to engine mounting
- Renew
- 20 Nm + 90° (1/4 turn further).

9 - Bolt

- Connecting bracket to body
- Renew
- 20 Nm + 90° (1/4 turn further).

10 - Bolt

- Engine mounting to body
- Renew
- 40 Nm + 90° (1/4 turn further).

11 - Bolts

- Engine mounting to engine support
- Renew
- 60 Nm + 90° (1/4 turn further).

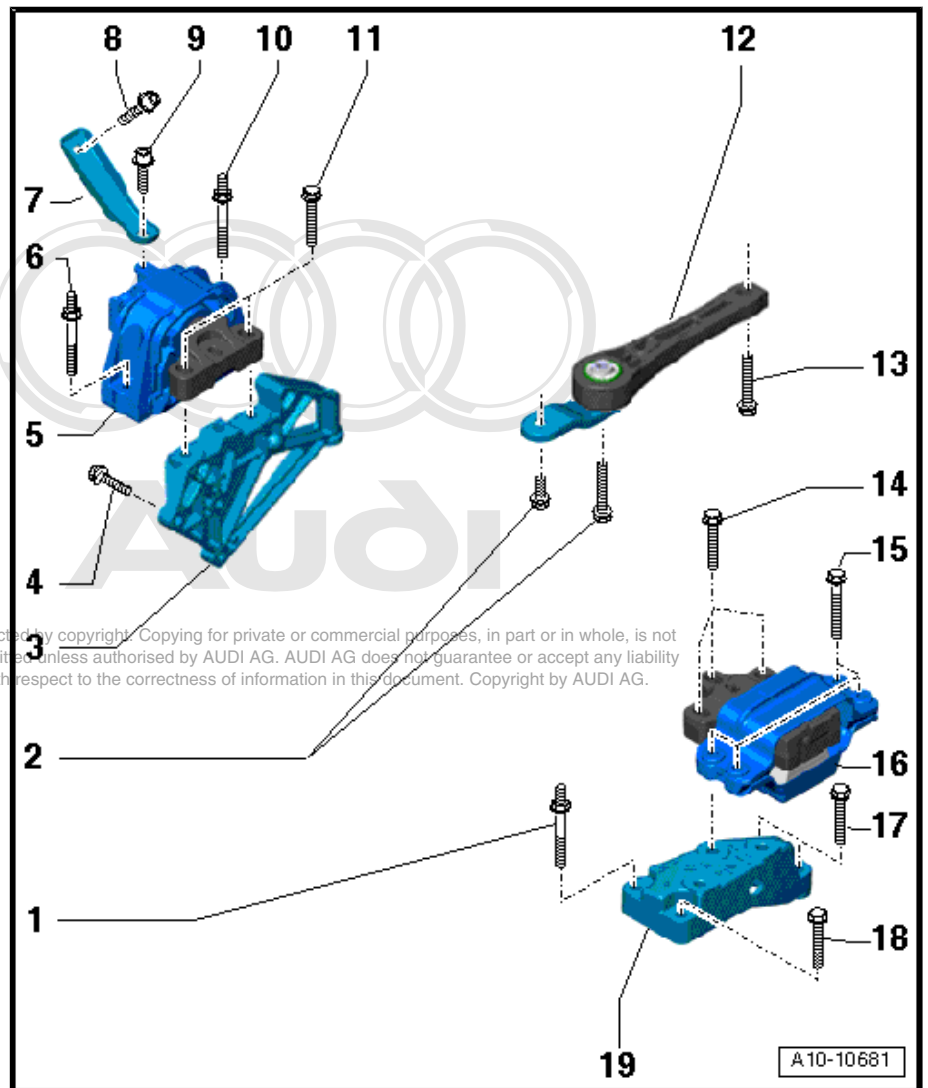



12 - Pendulum support

13 - Bolt

- Pendulum support to subframe
- Renew
- 100 Nm + 90° (1/4 turn further).

14 - Bolt

- Gearbox mounting to gearbox support
- Tightening torque ⇒ Rep. Gr. 34

15 - Bolt

- Gearbox mounting to body
- Tightening torque ⇒ Rep. Gr. 34

16 - Gearbox mounting

- With support arm

17 - Bolt

- Gearbox support to gearbox
- Tightening torque ⇒ Rep. Gr. 34

18 - Bolt

- Gearbox support to gearbox
- Tightening torque ⇒ Rep. Gr. 34

19 - Gearbox support

2.2 Checking adjustment of assembly mountings (engine/gearbox mountings)

Procedure

- Lift out activated charcoal filter from retainer
-in direction of arrow- with pipes connected and lay aside.

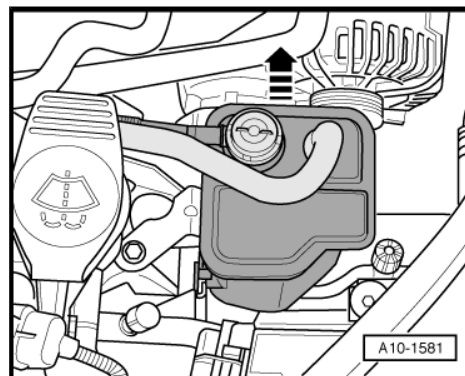

Proceed as follows:

- Check distances at mounting (right-side) for engine and gear-box:
- The two bolt heads -2- must be parallel with edge of support arm -3- for engine mounting.
- There must be a distance of -x- = 16 mm between engine mounting -1- and engine support -4-.

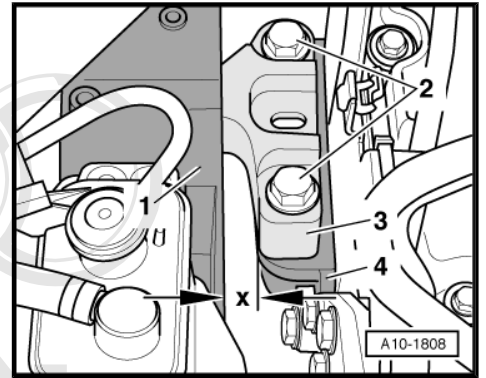

 **Note**

Distance -x- = 16 mm can also be checked with a metal rod of suitable size, or similar.

- If the distance measured is too large or small, the assembly mountings must be adjusted => [page 27](#)

Protected by copyright. Copying for private or commercial purposes, in part or in whole, is not permitted unless authorised by AUDI AG. AUDI AG does not guarantee or accept any liability with respect to the correctness of information in this document. Copyright by AUDI AG.

2.3 Adjusting assembly mountings

Special tools and workshop equipment required

- ◆ Support bracket -10 - 222 A-
- ◆ 2x spindle -10 - 222 A /11-
- ◆ Adapter -10 - 222 A /20-(2x)
- ◆ Hooks -10 - 222 A /2-
- ◆ Engine support bracket (basic set) -T40091-
- ◆ Engine support bracket (supplementary set) -T40093- with -T40093/3-2- and -T40093/3-3-

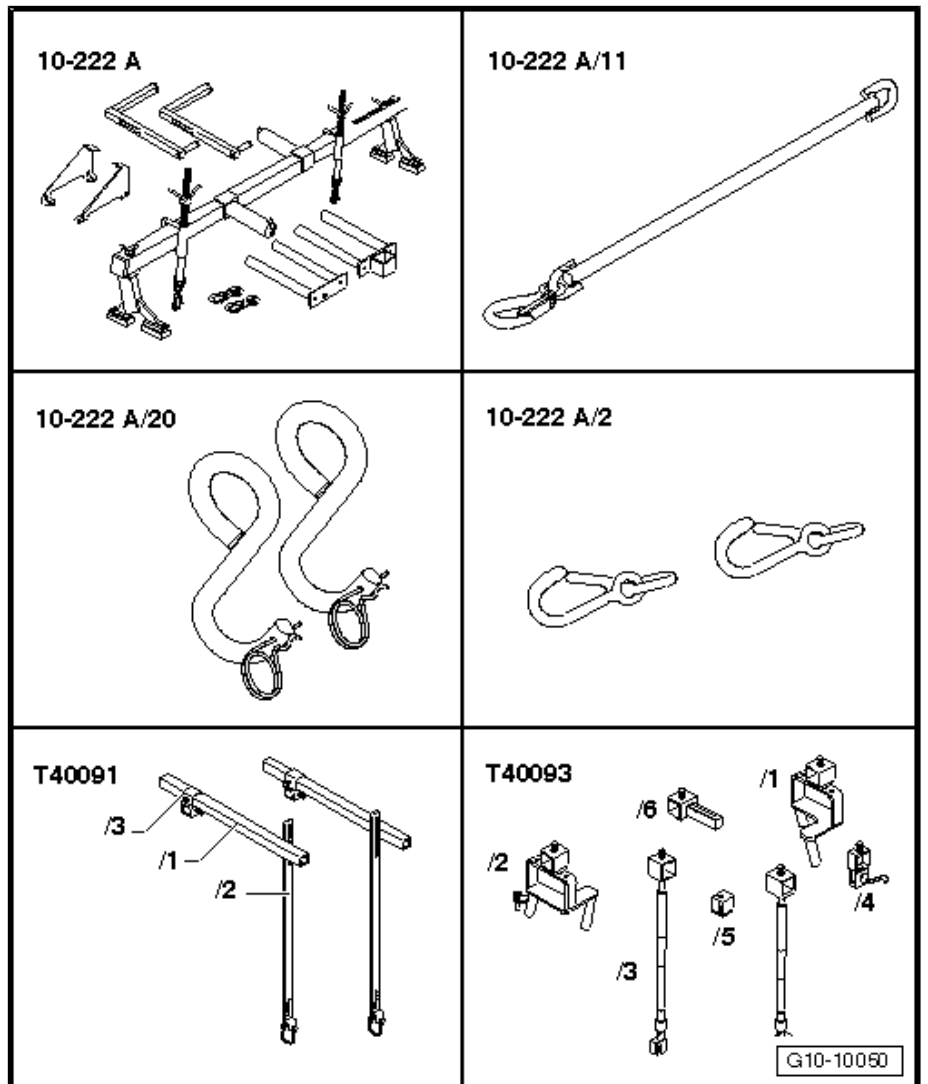

Proceed as follows:

- Tightening torques => [page 25](#) .



- Unplug electrical connector at air mass meter -G70- -3-.
- Open clamps -1 and 2- and disconnect air intake hose from air mass meter.
- Detach air intake connection at lock carrier -4-.
- Pull off engine cover panel.

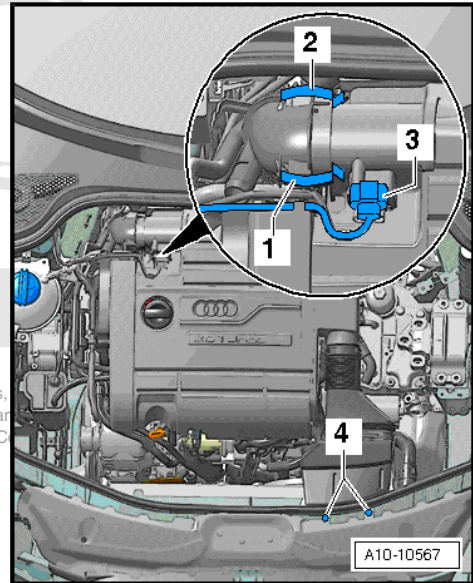

Protected by copyright. Copying for private or commercial purposes, permitted unless authorised by AUDI AG. AUDI AG does not guarantee with respect to the correctness of information in this document. C

- Pull activated charcoal filter with hoses attached upwards out of the retainer -arrow- and place to side.
- Remove bracket for activated charcoal filter.

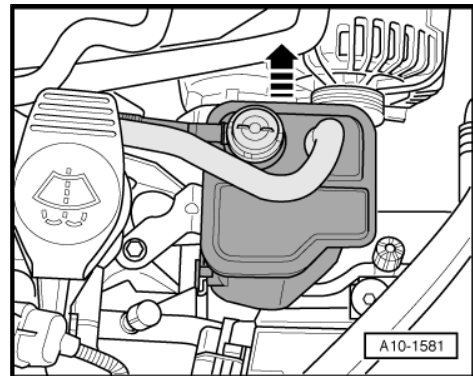

- Disconnect coolant pipe -arrows-.

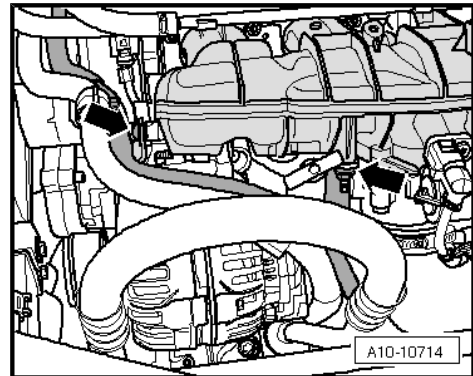

- Detach gear selector cable -arrow-.

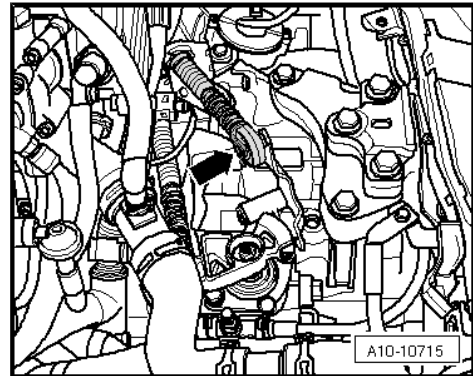

– Position support bracket -10 - 222 A- on bolted flanges of wing panels using the following tools:

- ◆ 2x Rack -10 - 222 A /1-
- ◆ Support bracket -10 - 222 A-
- ◆ Spindle -10 - 222 A /11- (spindle faces front)
- ◆ Hooks -10 - 222 A /2-
- ◆ Adapter -10 - 222 A /20-
- ◆ Connecting piece -T40091/3- (2x)

– Attach spindle 10 - 222 A /11- with hook 10 - 222 A /2- and adapter -10 - 222 A /20- to gearbox lifting eye.

– Tighten spindle slightly to take up weight of engine/gearbox assembly.

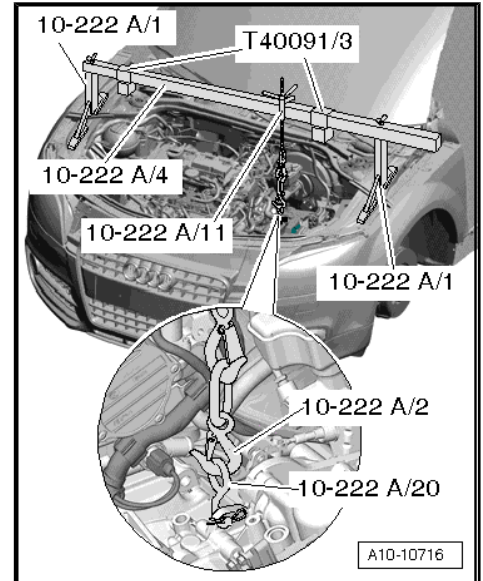

– Fit adapter -T40092/3-2- (left-side) and -T40093/3-3- (right-side) to supports -T40093/3- .

– Unbolt earth wire from longitudinal member (left-side).

– Remove connecting bolt for front section of longitudinal member on left and right.

– Secure adapter -T40092/3-2- (left-side) and -T40093/3-3- (right-side) to longitudinal members using the removed bolts -arrow-.



Note

The illustration shows the left side of the vehicle.

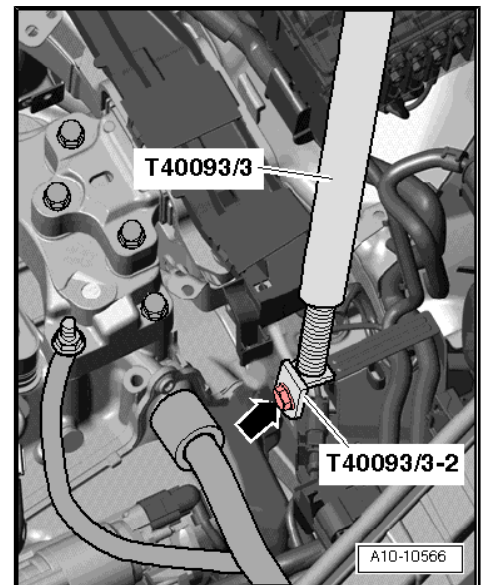

– Fit square-section pipes -T40091/1- with connecting pieces -T40093/4- into connecting pieces -T40091/3- and supports -T40093/3-- as shown in illustration.

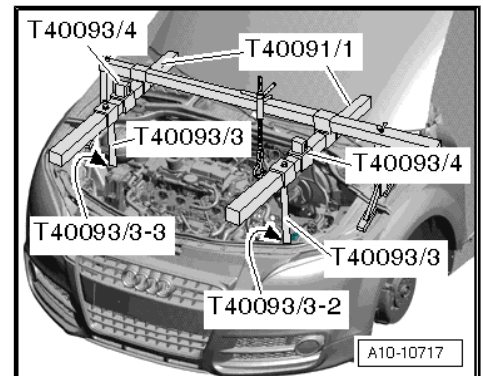



- Push support -T40091/2- with sliding support -T40093/5- into the two connecting pieces -T40093/4- .



WARNING

Accident risk from loose components of support bracket.

- ◆ *Secure support -T10091/2- with pins and split pins of connecting pieces -T40093/4- .*
- ◆ *Secure connecting pieces and supports with clamping bolts.*

- Fit spindle -10 - 222 A /11- with adapter -10 - 222 A /20- onto sliding support and onto engine lifting eye.
- Take up weight of engine/gearbox assembly by evenly tightening two spindles.

- Unscrew bolts -arrows- on engine assembly mounting one after the other, renew them (if not already renewed when engine was installed) and screw in loosely.

- Unscrew bolts -arrows- on gearbox assembly mounting one after the other, renew them (if not already renewed when engine was installed) and screw in loosely.
- Slacken bolts on left and right-hand support arms by about two turns each.

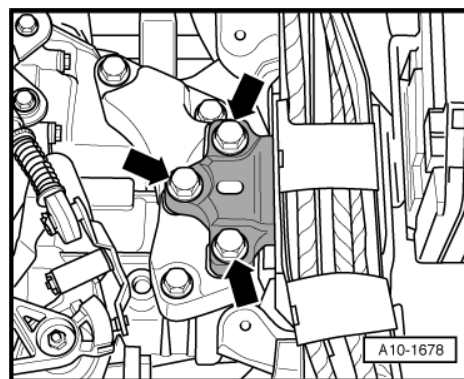
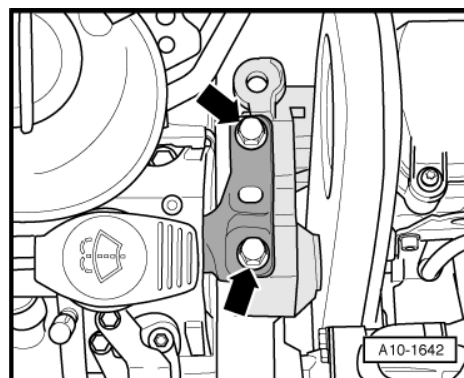
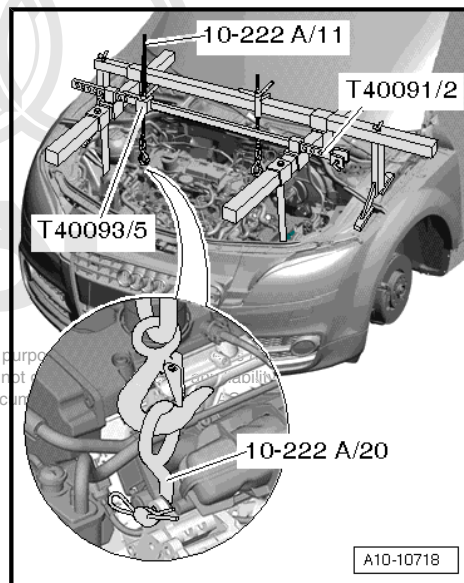

- Using a tyre iron, adjust engine/gearbox assembly between engine mounting -1- and engine support -4- until the specifications listed below are obtained:
- The two bolt heads -2- must be parallel with the edge of the support arm -3-.
- There must be a distance of $-x- = 16 \text{ mm}$ between engine mounting -1- and engine support -4-.

 **Note**

Distance $-x- = 16 \text{ mm}$ can also be checked with a metal rod of suitable size, or similar.

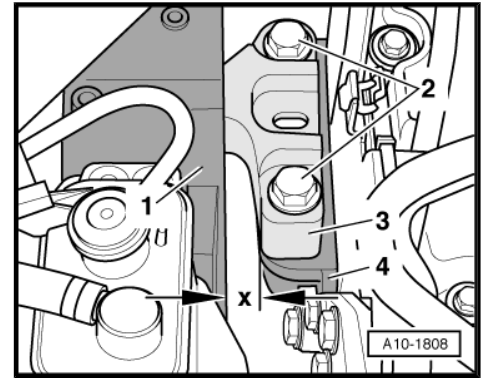

- Tighten bolts of assembly mounting at gearbox.
- Ensure that the edges of the support arm (on the gearbox assembly mounting) -1- and gearbox mounting -2- are parallel.
- Dimension $-x-$ must be identical on both sides of mounting.

Protected by copyright. Copying for private or commercial purposes, in part or in whole, is not permitted without the prior written consent or acceptance of any liability with respect to the correctness of information in this document. Copyright by AUDI AG.

Tighten bolts for assembly mounting

Remaining installation steps are carried out in reverse sequence; note the following:

- Tighten bolts for front section of longitudinal member \Rightarrow Rep. Gr. 50 .

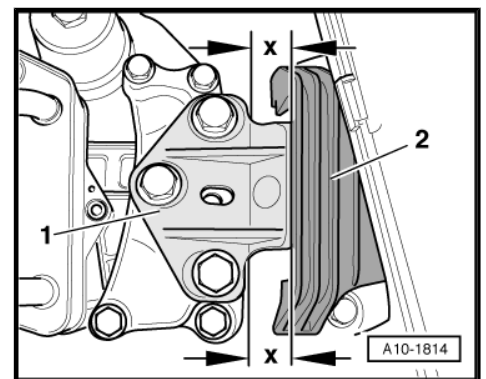

13 – Crankshaft group

1 Cylinder block (pulley end)

1.1 Poly V-belt, bracket for ancillaries - exploded view

i Note

Before removing, mark direction of rotation of poly V-belt with chalk or felt-tipped pen. If the belt runs in the opposite direction when it is refitted, this can cause breakage. Ensure that the belt is properly seated in the pulleys when installing.

1 - Vibration damper

- For poly V-belt
- Removing and installing
⇒ [page 38](#)

2 - Bolt

- 10 Nm + 90°

Renew ⇒ Parts catalogue

3 - Bolt

- 23 Nm

4 - Tensioner for poly V-belt

- Pivot with open-end spanner to slacken poly V-belt
- Secure tensioner in position using locking pin - T10060A-

5 - Bracket for ancillaries

- Removing and installing
⇒ [page 35](#)
- Tightening sequence
⇒ [page 33](#)

6 - Bolt

- 23 Nm

7 - Nut

- 23 Nm

8 - Alternator

- Removing and installing
⇒ Electrical system; Repair group 27
- To facilitate attachment of alternator, knock back threaded bushes for alternator securing bolts slightly

9 - Bolt

- Apply locking fluid when fitting
- Locking fluid ⇒ Parts catalogue

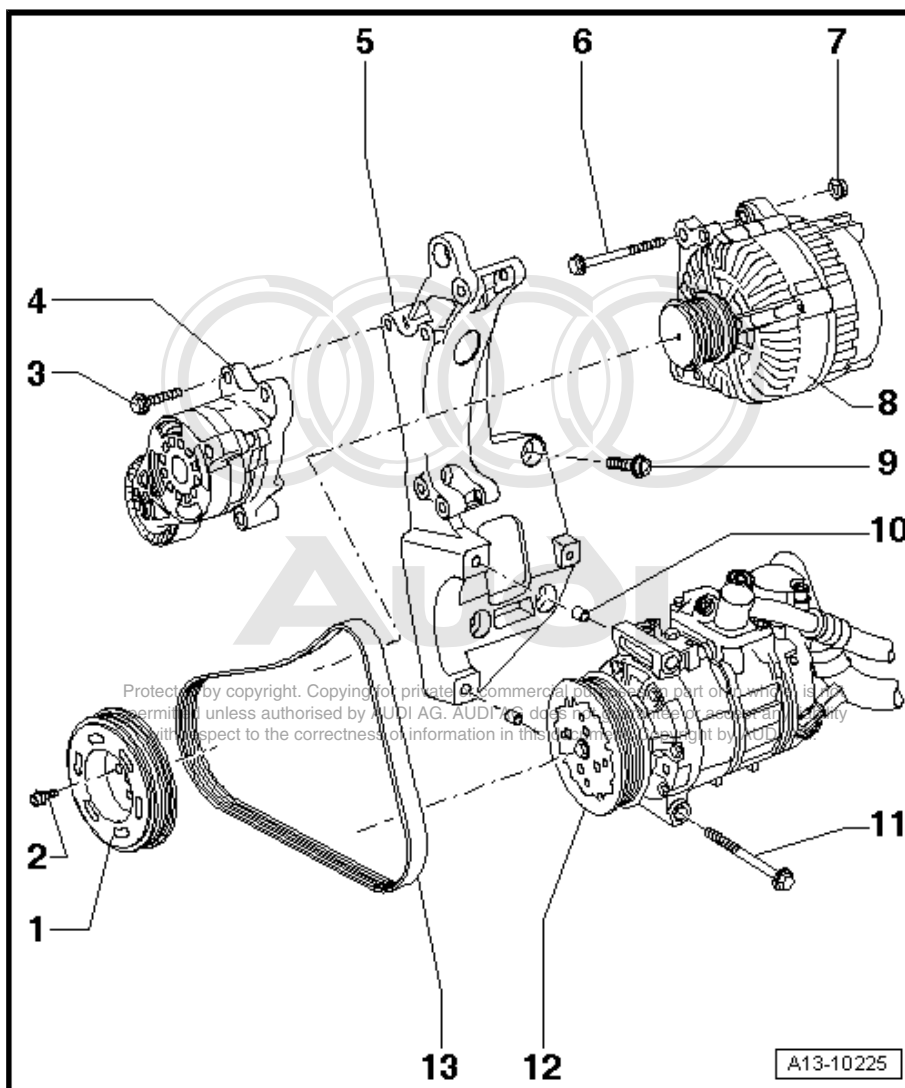

- ❑ Tightening sequence ⇒ [page 33](#)

10 - Bush

- ❑ 2 x

11 - Bolt

- ❑ 25 Nm

12 - Air conditioner compressor

- ❑ Removing and installing ⇒ Air conditioning; Repair group 87

13 - Poly V-belt

- ❑ Routing of poly V-belt ⇒ [page 33](#)
- ❑ Check for wear
- ❑ Do not kink
- ❑ Removing and installing ⇒ [page 33](#)

Routing of poly V-belt

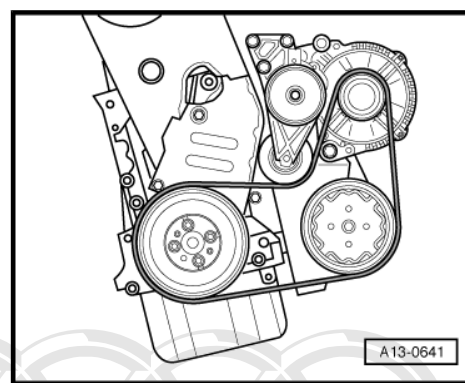

Tightening sequence on bracket for ancillaries

– Proceed as follows:

1. Screw in bolts -1 ... 6- hand-tight.
2. Tighten bolts -1 ... 6- to 45 Nm.

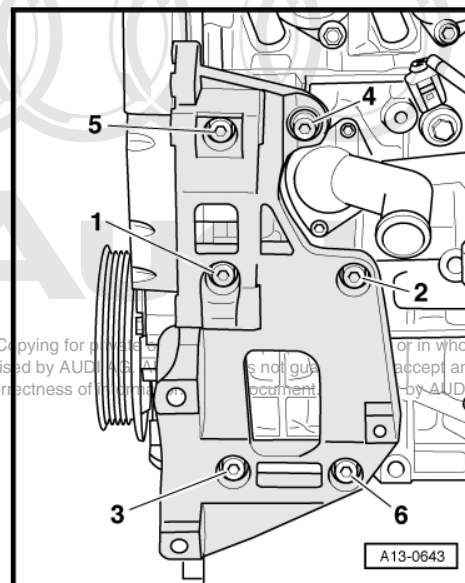

Protected by copyright. Copying for private use, or in whole, is not permitted unless authorised by AUDI AG. This document is not guaranteed to be correct and AUDI AG is not liable for any damage or liability with respect to the correctness of the information.

1.2 Removing and installing poly V-belt

Special tools and workshop equipment required



◆ Locking pin -T10060A-

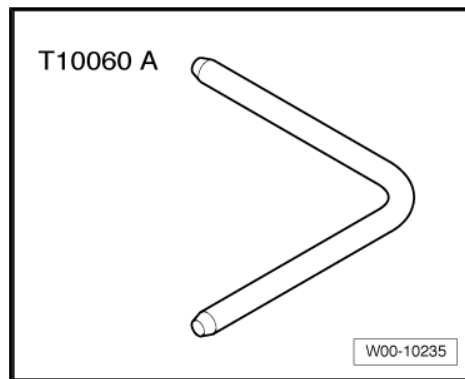

Removing

- Unplug electrical connector at air mass meter -G70- -3-.
- Open clamps -1 and 2- and disconnect air intake hose from air mass meter.
- Detach air intake connection at lock carrier -4-.
- Pull off engine cover panel.

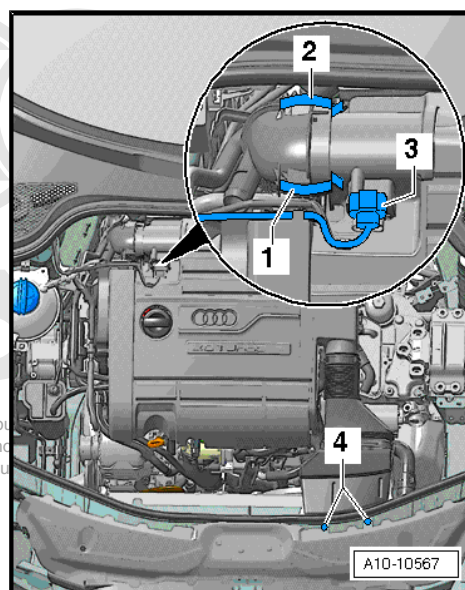

Protected by copyright. Copying for private or commercial purposes is not permitted unless authorised by AUDI AG. AUDI AG does not accept any liability with respect to the correctness of information in this document.

- Lift out activated charcoal filter from retainer with pipes connected -arrow- and lay aside.

i Note

Before removing, mark direction of rotation of poly V-belt with chalk or felt-tipped pen. If the belt runs in the opposite direction when it is refitted, this can cause breakage.

- Mark direction of rotation of poly V-belt.
- To slacken poly V-belt, turn tensioner in -direction of arrow-.

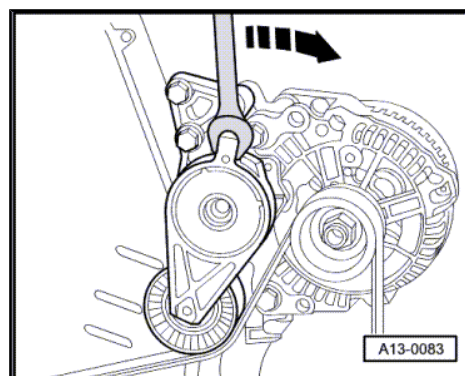
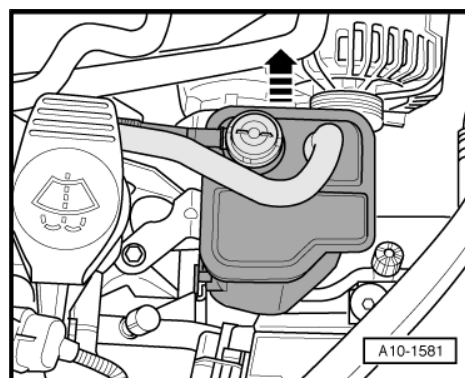

- Lock tensioner in position with locking pin -T10060A- .
- Remove poly V-belt.

Installing

Installation is carried out in the reverse order; note the following:

 **Note**

Before fitting poly V-belt, make sure all ancillary units (alternator and air-conditioner compressor) are firmly secured.

- Fit the poly V-belt onto the crankshaft and air conditioner compressor pulleys.
- Then position poly V-belt on alternator pulley and release tensioner.
- Check that poly V-belt is properly seated.
- Start engine and check that belt runs properly.

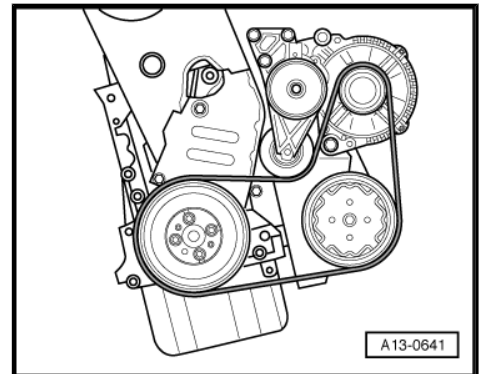
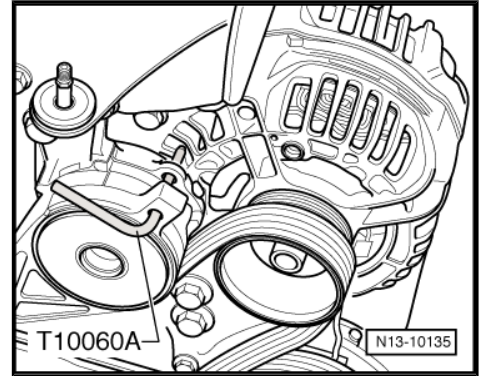

1.3 Removing and installing bracket for ancillaries

Special tools and workshop equipment required

- ◆ Locking pin -T10060A-



Protected by copyright. Copying for private or commercial purposes, in part or in whole, is not permitted unless authorised by AUDI AG. AUDI AG does not guarantee or accept any liability with respect to the correctness of information in this document. Copyright by AUDI AG.

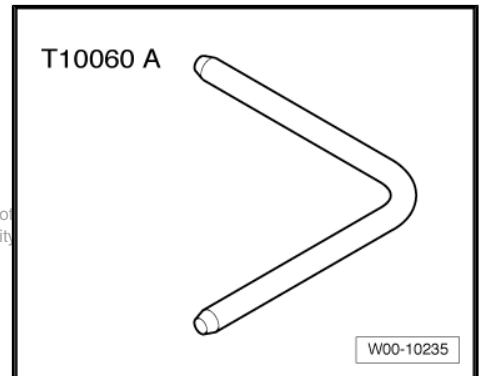



Removing

- Unplug electrical connector at air mass meter -G70- -3-.
- Open clamps -1 and 2- and disconnect air intake hose from air mass meter.
- Detach air intake connection at lock carrier -4-.
- Pull off engine cover panel.

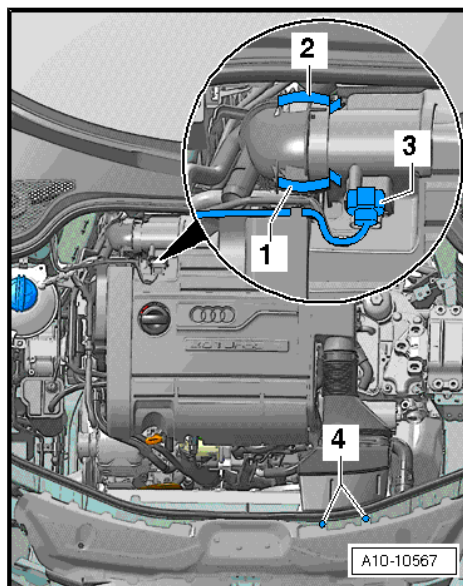

- Lift out activated charcoal filter from retainer with pipes connected -arrow- and lay aside.



Note

Before removing, mark direction of rotation of poly V-belt with chalk or felt-tipped pen. If the belt runs in the opposite direction when it is refitted, this can cause breakage.

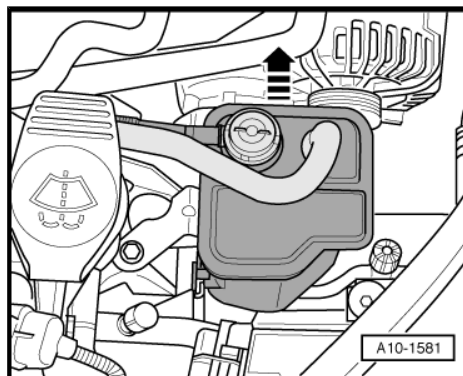

- To slacken poly V-belt, turn tensioner in -direction of arrow-.

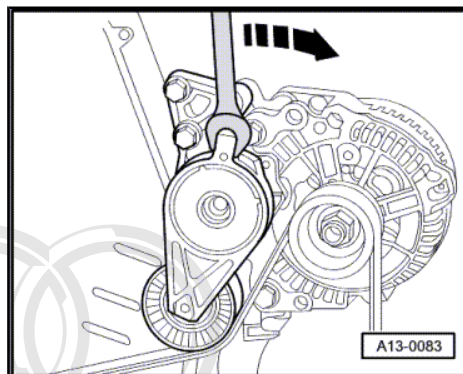

- Lock tensioner in position with locking pin -T10060A-.
- Take off poly V-belt.

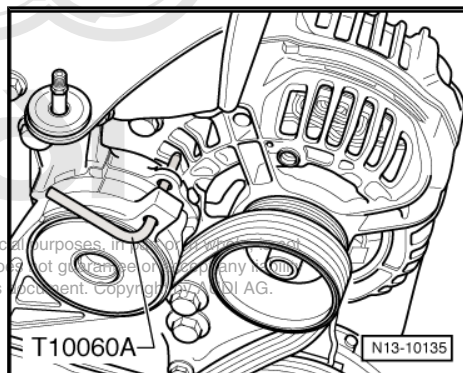

Protected by copyright. Copying for private or commercial purposes, in whole or in part, is not permitted unless authorised by AUDI AG. AUDI AG does not give any warranty or liability with respect to the correctness of information in this document. Copyright © AUDI AG.

- Remove tensioner for poly V-belt -arrows-.
- Discharge the refrigerant system => Rep. Gr. 87 ; Air conditioner system with refrigerant R134a .
- Remove alternator => Electrical system; Repair group 27 .

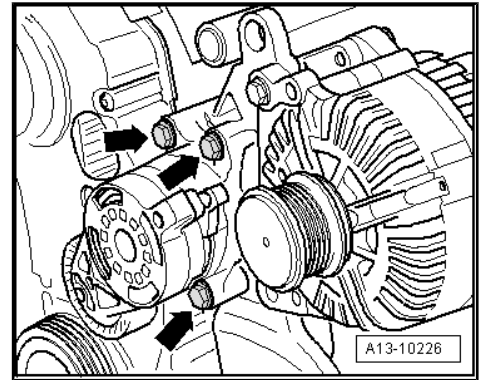

- Remove centre noise insulation -fasteners 1 ... 4-.

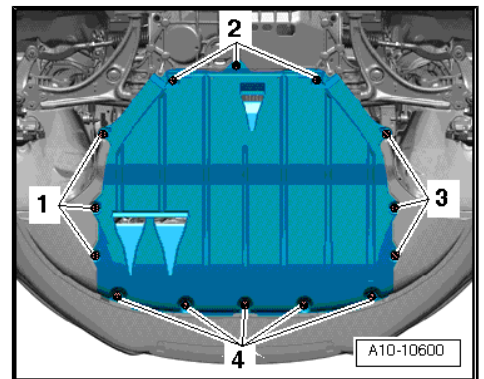

- Remove right noise insulation -arrows-.

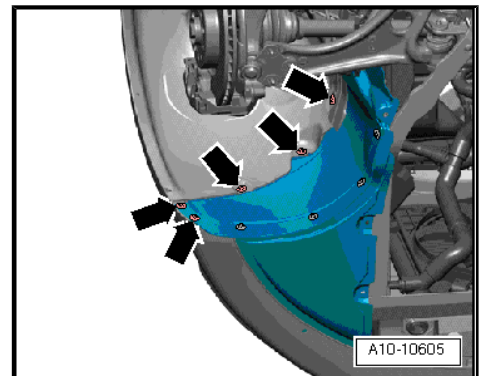

- Remove noise insulation frame -arrow-.
- Remove air conditioner compressor => Rep. Gr. 87 ; Heating, air conditioning system .

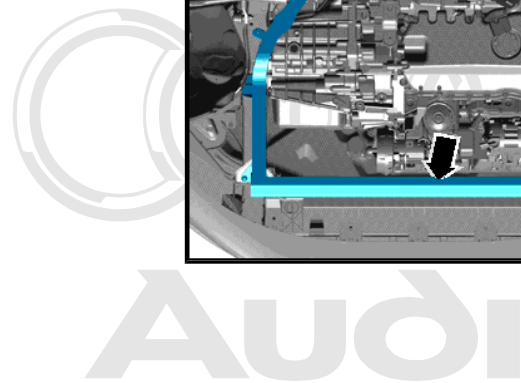
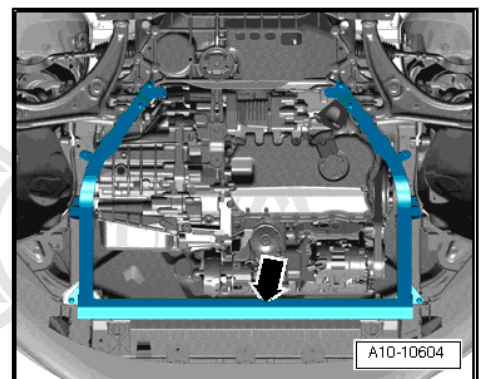

Protected by copyright. Copying for private or commercial purposes, in part or in whole, is not permitted unless authorised by AUDI AG. AUDI AG does not guarantee or accept any liability with respect to the correctness of information in this document. Copyright by AUDI AG.



- Detach bracket for ancillaries: bolts -1 ... 6-

Installing

Installation is carried out in the reverse order; note the following:

- Tightening torques ⇒ [page 32](#)

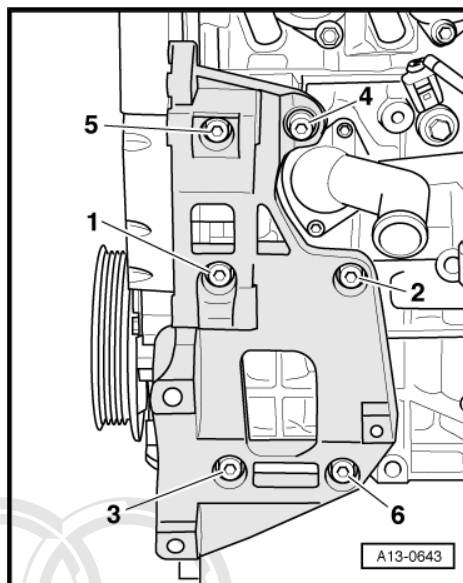

- Tighten bolts in the sequence -1 ... 6-.
- Install alternator ⇒ Electrical system; Repair group 27 .
- Install air conditioner compressor ⇒ Rep. Gr. 87 ; Heating, air conditioning system .
- Install poly V-belt ⇒ [page 33](#) .
- Connect battery. Procedures required ⇒ Electrical system; Repair group 27 .

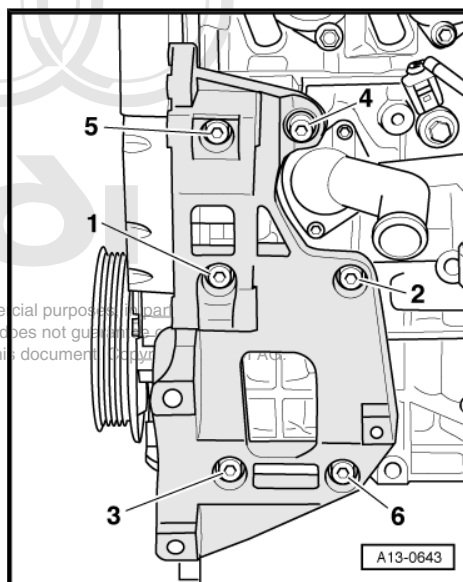

Protected by copyright. Copying for private or commercial purposes is not permitted unless authorised by AUDI AG. AUDI AG does not guarantee the accuracy with respect to the correctness of information in this document.

1.4 Removing and installing vibration damper

Removing

- Poly V-belt must be removed ⇒ [page 33](#) .
- Remove centre noise insulation -fasteners 1 ... 4-

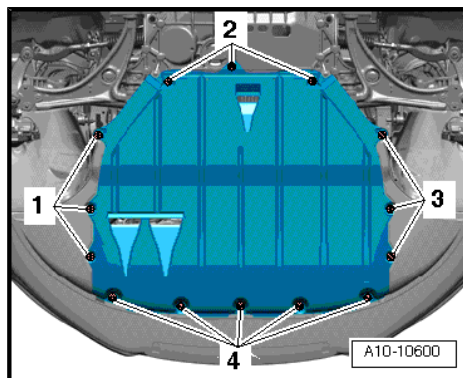

- Remove right noise insulation -arrows-.

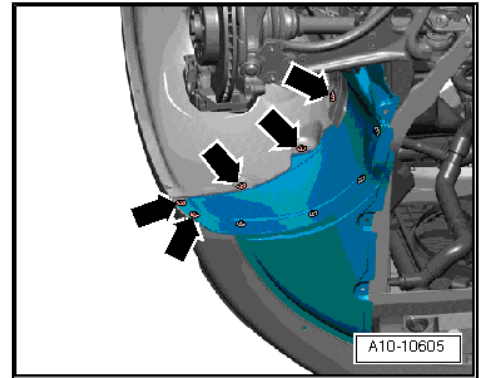

- Remove noise insulation frame -arrow-.

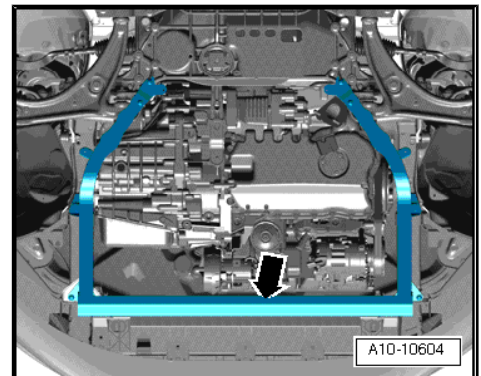

- Unscrew vibration damper and remove.

i Note

To loosen and tighten the vibration damper, counterhold with ring spanner on centre bolt.

Installing

Installation is carried out in the reverse order; note the following:

- Tightening torques ⇒ [page 32](#)

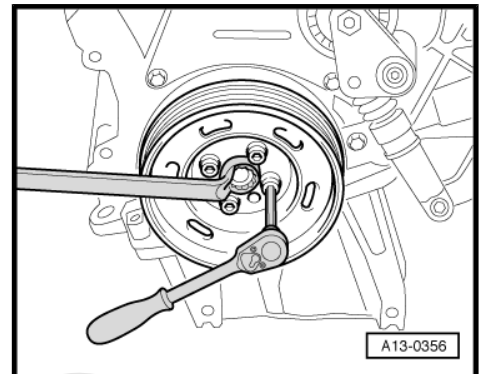

- When installing the vibration damper, use only genuine bolts (same as original equipment): ⇒ Parts catalogue .
- ◆ The vibration damper can only be installed in one position. The hole -arrow- in the crankshaft vibration damper must be located over the projection on the toothed belt sprocket.

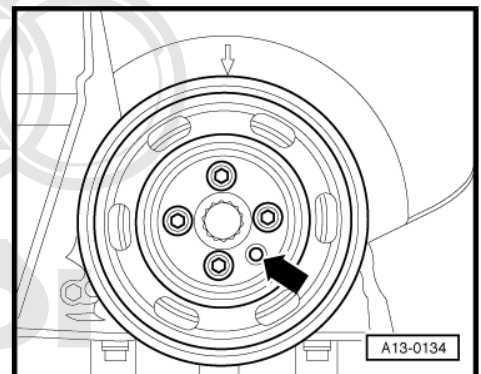

Protected by copyright. Copying for private or commercial purposes, in part or in whole, is not permitted unless authorised by AUDI AG. AUDI AG does not guarantee or accept any liability with respect to the correctness of information in this document. Copyright by AUDI AG.

1.5 Front sealing flange - exploded view

1 - Bolt

- 90 Nm + 90° (1/4 turn) further
- Renew
- Do not lubricate with oil
- Attaching counterhold tool 3415 ⇒ [page 65](#)

2 - Crankshaft sprocket

- Contact surface between sprocket and crankshaft must be free of oil
- Can only be installed in one position

3 - Bolt

- Tightening sequence ⇒ [page 40](#)

4 - Oil seal

- Renewing ⇒ [page 41](#)
- Do not lubricate with oil

5 - Sealing flange (front)

- Must be positioned on dowel pins
- Removing and installing ⇒ [page 44](#)

6 - Dowel pins

7 - Diamond-coated washer for toothed belt sprocket

- Renew washer if toothed belt sprocket is removed

8 - Bolt

- Tightening sequence ⇒ [page 40](#)

9 - Cylinder block

- Removing and installing crankshaft ⇒ [page 53](#)
- Dismantling and assembling pistons and conrods ⇒ [page 60](#)

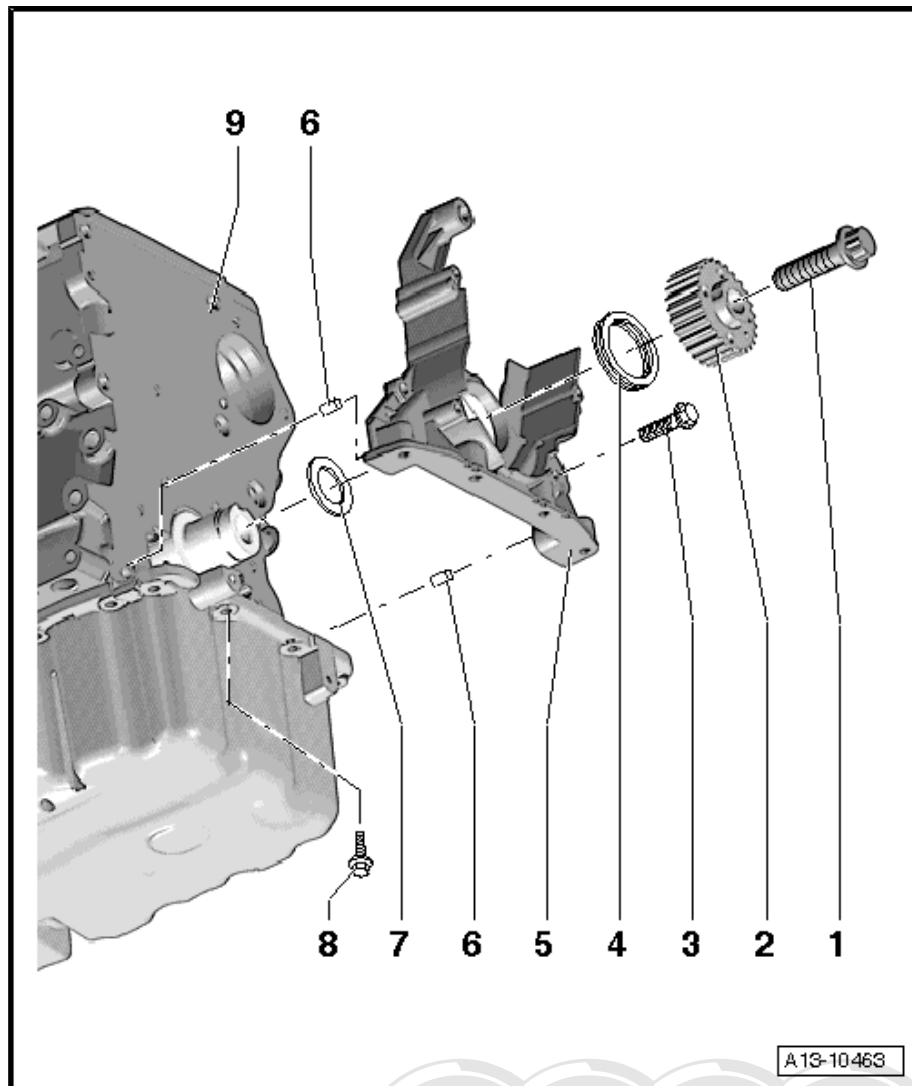

Tightening sequence for front sealing flange

– Proceed as follows:

1. Screw in bolts -1 ... 10- hand-tight.
2. Tighten bolts -1 ... 6- in diagonal sequence and in stages to 15 Nm.
3. Tighten bolts -7 ... 10- to 15 Nm.

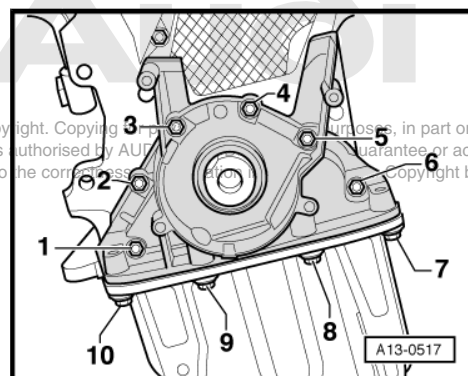

Protected by copyright. Copying or reproduction in part or in whole, is not permitted unless authorised by AUDI AG. AUDI AG does not guarantee or accept any liability with respect to the correctness of this information. Copyright by AUDI AG.

1.6 Renewing crankshaft oil seal - pulley end

Special tools and workshop equipment required

- ◆ Oil seal extractor -3203-
- ◆ Counterhold tool -3415-
- ◆ Assembly tool -T10053-
- ◆ Torque wrench -V.A.G 1331-
- ◆ Torque wrench -V.A.G 1332-

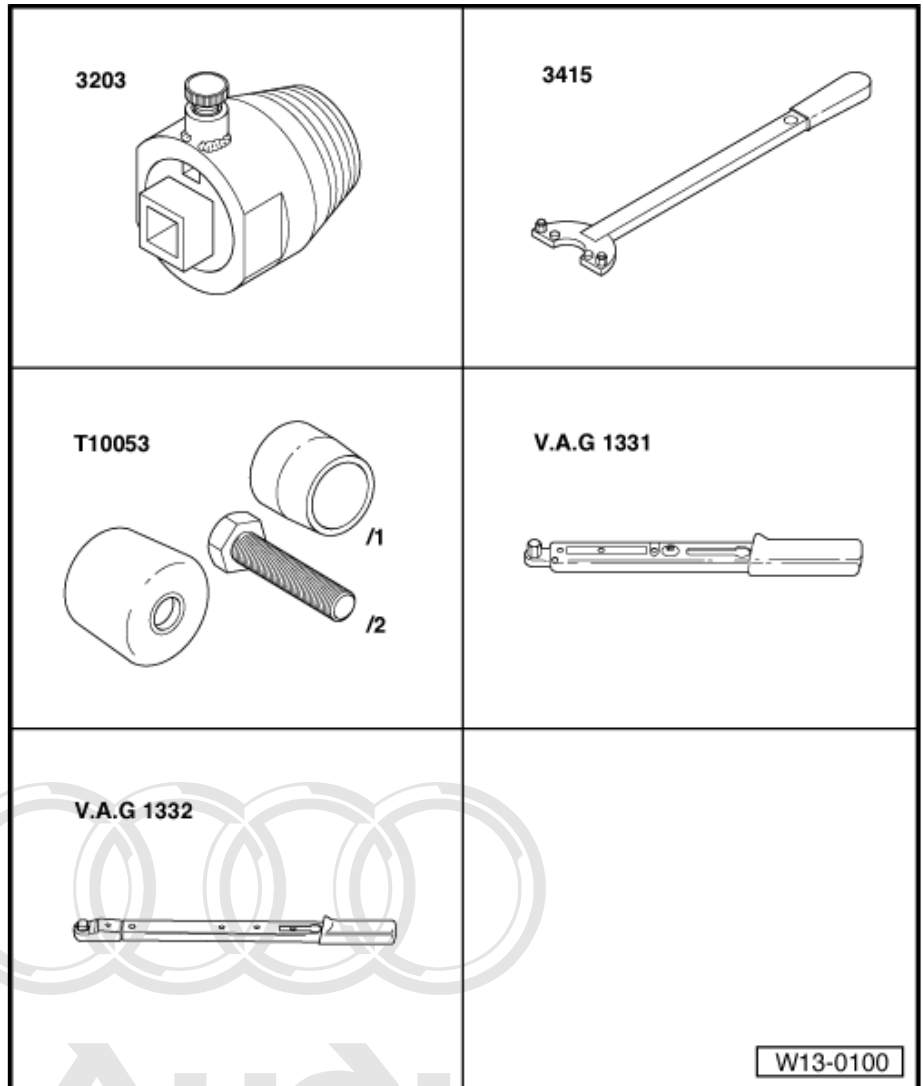

Removing

- Remove poly V-belt ⇒ [page 33](#)
- Remove toothed belt ⇒ [page 63](#)
- Remove crankshaft toothed belt sprocket. To do this, counterhold sprocket with special tool -3415- .

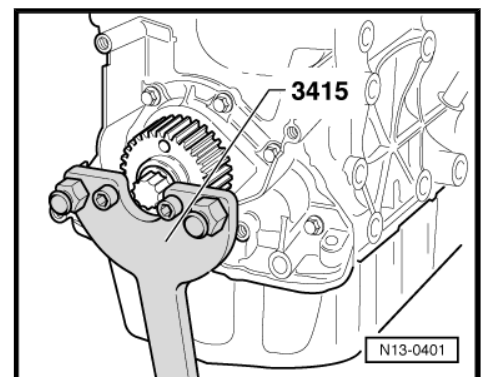



- Unscrew central bolt -1- for crankshaft toothed belt sprocket -2- and remove sprocket.
- Remove diamond-coated washer -3- from toothed belt sprocket.
- To guide oil seal extractor, screw central bolt into crankshaft onto stop by hand.
- Unscrew inner part of oil seal extractor -3203- nine turns (approx. 20 mm) from the outer part and lock in position with the knurled screw.

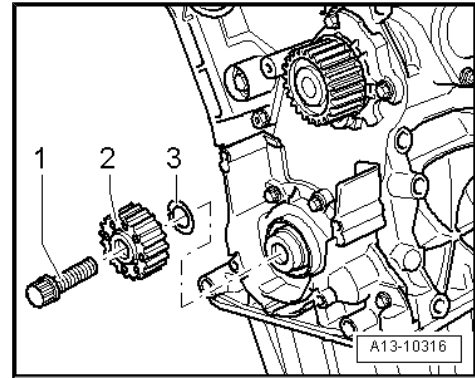

- Lubricate threaded head of oil seal extractor -3203-, place it in position and, while exerting firm pressure, screw it into oil seal as far as possible.
- Loosen knurled screw and turn inner part against crankshaft until oil seal is pulled out.
- Clamp flats of oil seal extractor in vice. Remove oil seal with pliers.

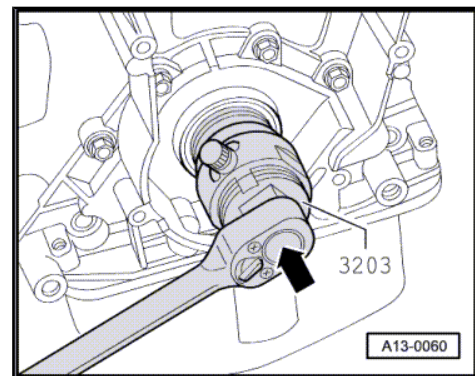

Installing

- Tightening torques ⇒ [page 40](#)
- Clean contact surface and sealing surface.
- Remove oil residue from crankshaft journal with a clean cloth.
- Position guide sleeve T10053/1 from assembly tool -T10053- on crankshaft journal.
- Push oil seal over guide sleeve onto crankshaft journal.

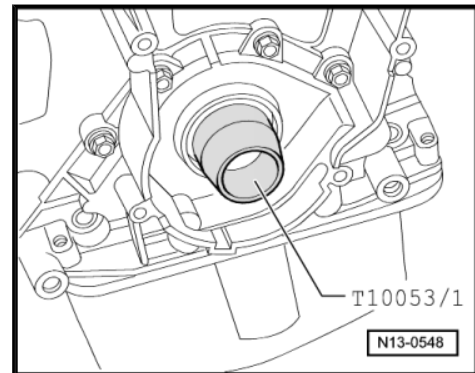

- Press in oil seal with central bolt of toothed belt sprocket and thrust sleeve of assembly tool -T10053- until flush.

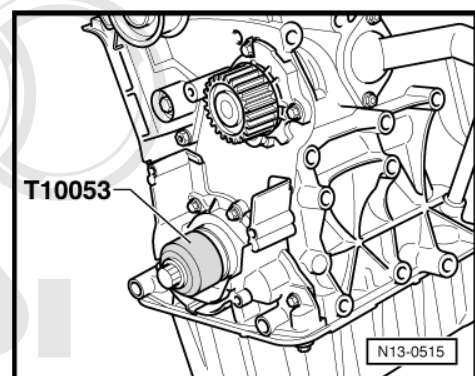

Protected by copyright. Copying for private or commercial purposes, in part or in whole, is not permitted unless authorised by AUDI AG. AUDI AG does not guarantee or accept any liability with respect to the correctness of information in this document. Copyright by AUDI AG.

- Install crankshaft toothed belt sprocket -2- with new diamond-coated washer -3- and new central bolt -1-.

 **Note**

- ◆ *Contact surfaces between toothed belt sprocket, diamond-coated washer and crankshaft must be free of oil.*
- ◆ *Do not lubricate bolt for crankshaft sprocket.*

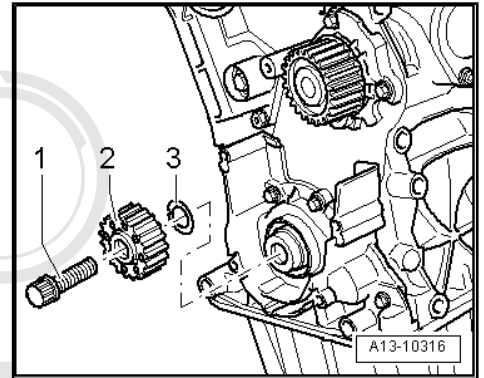

- Use counterhold tool -3415- to tighten crankshaft toothed belt sprocket.

Fit toothed belt (adjust valve timing) ⇒ [page 66](#)

- Install poly V-belt ⇒ [page 33](#).

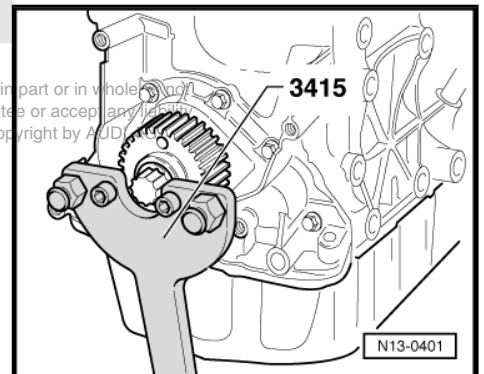





1.7 Removing and installing sealing flange (front)

Special tools and workshop equipment required

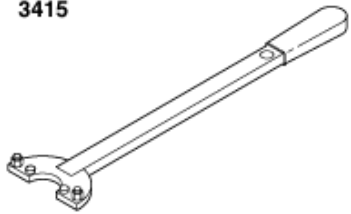
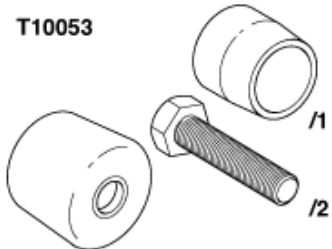
- ◆ Counterhold tool -3415-
- ◆ Assembly tool -T10053-
- ◆ Torque wrench -V.A.G 1331-
- ◆ Torque wrench -V.A.G 1332-
- ◆ Electric drill with plastic brush attachment
- ◆ Safety goggles
- ◆ Sealant ⇒ Parts catalogue

<p>3415</p> 	<p>T10053</p> 
<p>V.A.G 1331</p> 	<p>V.A.G 1332</p> 
<p>W13-0101</p>	

Removing

- Remove poly V-belt ⇒ [page 33](#) .
- Remove toothed belt ⇒ [page 63](#) .
- Remove crankshaft toothed belt sprocket. To do this, counterhold sprocket with special tool -3415- .

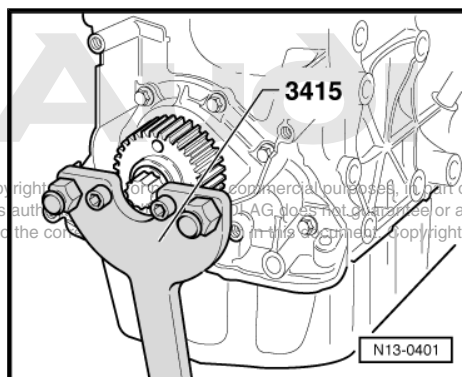

Protected by copyright. No part of this publication may be reproduced, stored in a retrieval system, or transmitted in any form or by any means, electronic, mechanical, photocopying, recording, or otherwise, without the prior written permission of Audi AG. Audi AG does not guarantee or accept any liability with respect to the content of this document. Copyright by AUDI AG.

- Unscrew central bolt -1- for crankshaft toothed belt sprocket -2- and remove sprocket.
- Remove diamond-coated washer -3- from toothed belt sprocket.

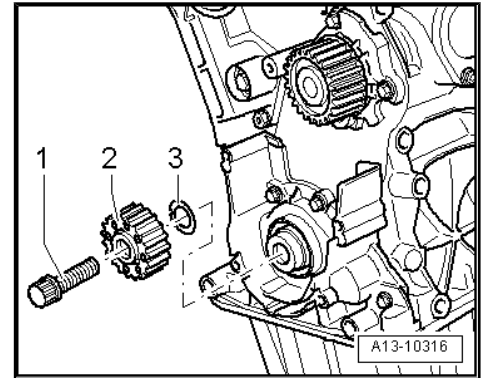

- Remove bolts -1 ... 10-.
- Lever off front sealing flange and remove.
- Drive out oil seal with flange removed.

Installing

- Tightening torque ⇒ [page 40](#)



Note

Place a cloth over the exposed section of the sump.

- Carefully remove any sealant residue on the cylinder block and sump.

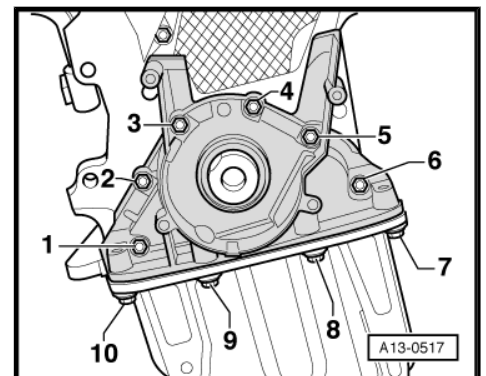

WARNING

Wear safety goggles.

- Remove sealant residue from sealing flange with rotating plastic brush or similar.
- Clean sealing surfaces; they must be free of oil and grease.

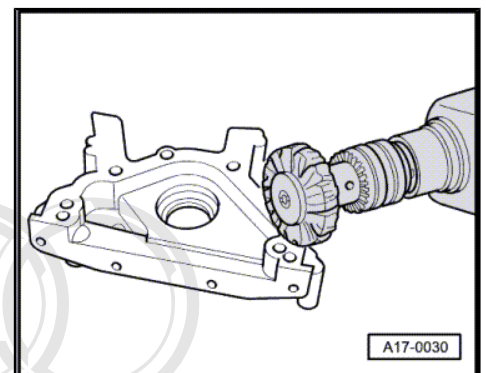

- Cut off tube nozzle at front marking (nozzle approx. 2 mm Ø).

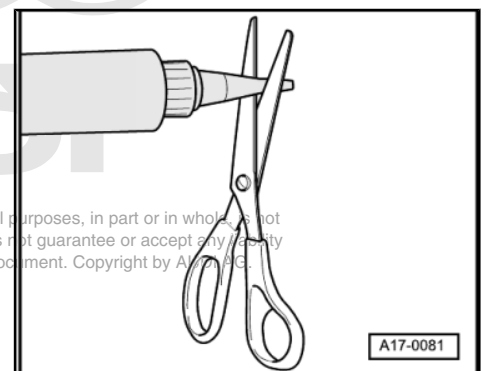

Protected by copyright. Copying for private or commercial purposes, in part or in whole, is not permitted unless authorised by AUDI AG. AUDI AG does not guarantee or accept any liability with respect to the correctness of information in this document. Copyright by AUDI AG.



- Apply a thin bead of sealant at the edge of the joint between the cylinder block and the sump -arrows-.

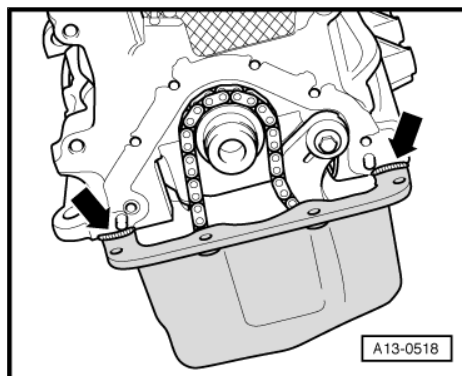

- Apply the bead of sealant onto the clean sealing surface of the sealing flange as illustrated -arrow-.
- Thickness of sealant bead: 2 ... 3 mm

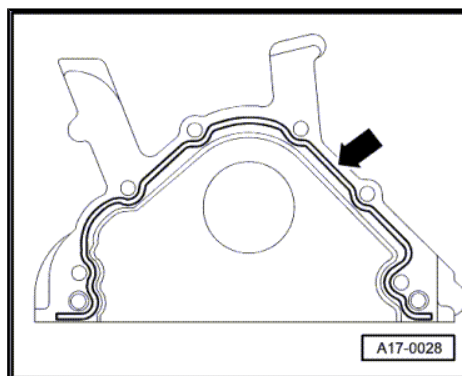

Caution

Make sure oil strainer is not clogged by excess sealant.

◆ *The bead of sealant must not be thicker than specified.*

Note

Sealant bead must not be wider than 3 mm, otherwise excess sealant could ingress into sump and clog strainer in oil intake pipe.

- Coat the lower sealing surface on the sealing flange lightly with sealant -hatched area-.

Note

The sealing flange must be installed within 5 minutes after applying sealant.

- Push the sealing flange carefully onto the dowel sleeves on the cylinder block.

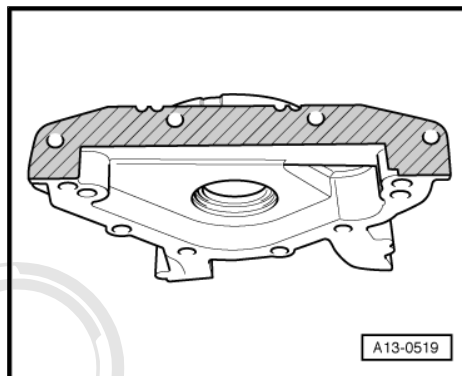

Note

Use guide sleeve -T10053/1- to attach sealing flange with oil seal fitted.

- Tighten sealing flange bolts in three stages as follows:

1. Screw in bolts -1 ... 10- hand-tight.
2. Tighten bolts -1 ... 6- in diagonal sequence and in stages.
3. Tighten bolts -7 ... 10-

- Install crankshaft oil seal (pulley end) => [page 42](#) .

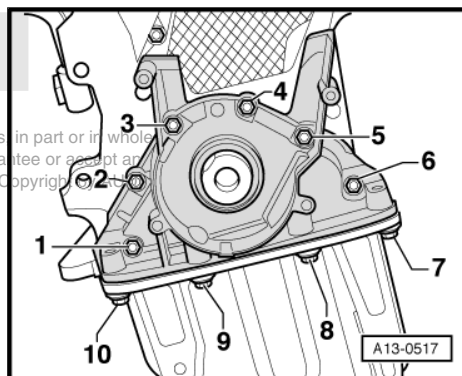

- Install crankshaft toothed belt sprocket -2- with new diamond-coated washer -3- and new central bolt -1-.

 **Note**

- ◆ *Contact surfaces between toothed belt sprocket, diamond-coated washer and crankshaft must be free of oil.*
- ◆ *Do not lubricate bolt for crankshaft sprocket.*

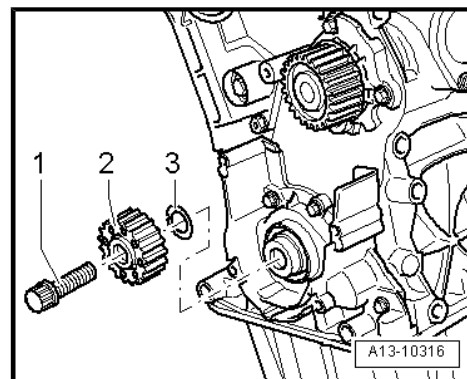

- Use counterhold tool -3415- to tighten crankshaft toothed belt sprocket.

Remaining installation steps are carried out in reverse sequence; note the following:

Installing toothed belt and adjusting valve timing ⇒ [page 66](#) .

- Install vibration damper ⇒ [page 38](#) .
- Install poly V-belt ⇒ [page 33](#) .

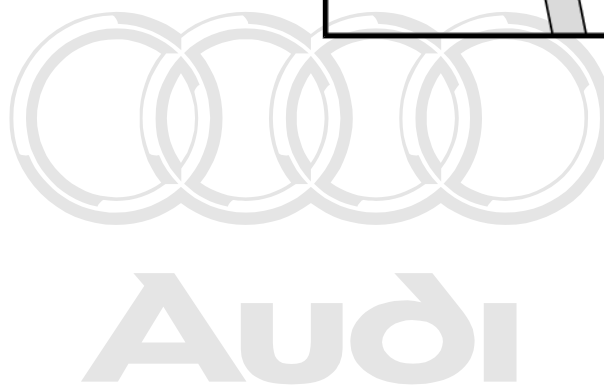
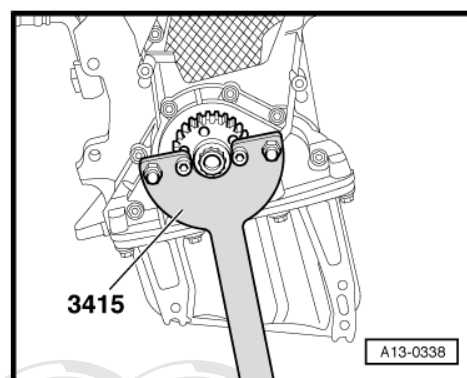

Protected by copyright. Copying for private or commercial purposes, in part or in whole, is not permitted unless authorised by AUDI AG. AUDI AG does not guarantee or accept any liability with respect to the correctness of information in this document. Copyright by AUDI AG.

2 Cylinder block (gearbox end)

2.1 Rear sealing flange and dual-mass flywheel - exploded view



Note

Servicing clutch:⇒ Rep. Gr. 30

1 - Bolt

- For dual-mass flywheel/ drive plate
- 60 + 90° (60 Nm + 90° (1/4 turn) further
- Renew

2 - Dual-mass flywheel

- Removing and installing dual-mass flywheel ⇒ [page 49](#)
- Can only be installed in one position. Holes are off-set

3 - Intermediate plate

- Must be positioned on dowel sleeves
- Do not damage/bend when assembling
- Is fitted on sealing flange ⇒ [page 49](#)

4 - Bolt

- Tightening sequence ⇒ [page 49](#)

5 - Sealing flange with oil seal (rear)

- Renew only as complete unit
- Use guide sleeve provided when fitting
- Removing and installing ⇒ [page 50](#)
- Do not lubricate/grease sealing lip of oil seal
- Before installing, remove oil residue from crankshaft journal with a clean cloth.
- Guide sleeve is not to be removed until sealing flange has been slipped onto crankshaft journal

6 - Dowel pin

7 - Cylinder block

- Removing and installing crankshaft ⇒ [page 53](#)
- Dismantling and assembling pistons and conrods ⇒ [page 60](#)

8 - Bolt

- Tightening sequence ⇒ [page 49](#)

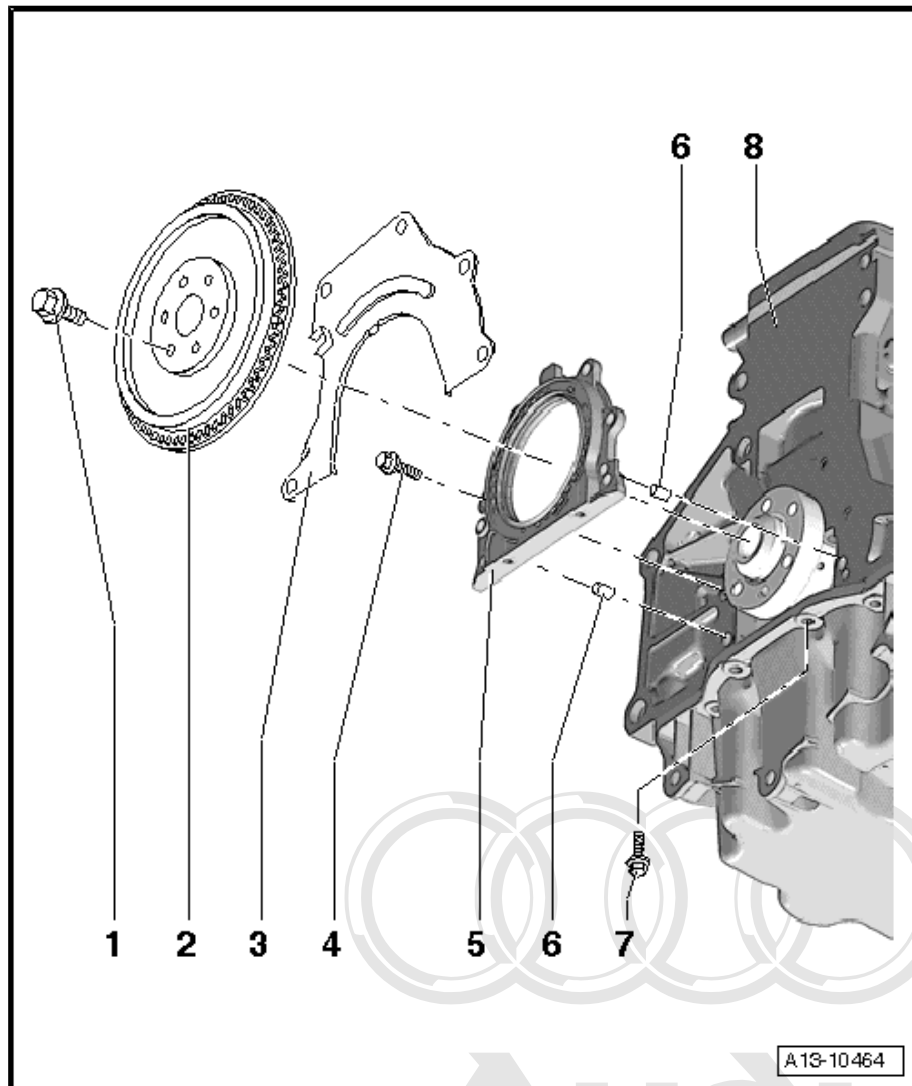

Protected by copyright. Copying for private or commercial purposes, in part or in whole, is not permitted unless authorised by AUDI AG. AUDI AG does not guarantee or accept any liability with respect to the correctness of information in this document. Copyright by AUDI AG.

Tightening sequence (gearbox end)

– Proceed as follows:

1. Screw in bolts -1 ... 8- hand-tight.
2. Tighten bolts -1 ... 6- in diagonal sequence and in stages to 15 Nm.
3. Tighten bolts -7 ... 8- to 15 Nm.

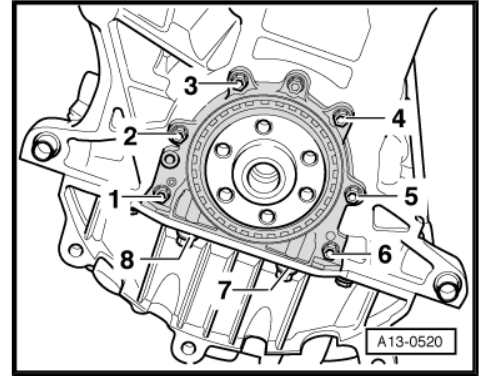
**Installing intermediate plate**

– Fit intermediate plate on sealing flange and push onto dowel sleeves -arrows-.

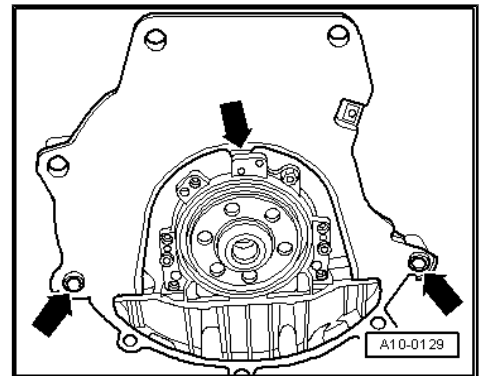

2.2 Removing and installing dual-mass flywheel

Special tools and workshop equipment required

- ◆ Counterhold tool -3067-

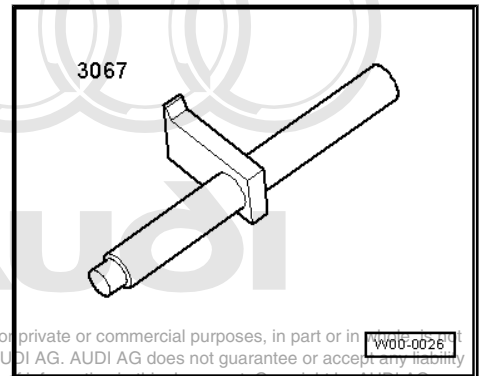

Protected by copyright. Copying for private or commercial purposes, in part or in whole, is not permitted unless authorised by AUDI AG. AUDI AG does not guarantee or accept any liability with respect to the correctness of information in this document. Copyright by AUDI AG.

Removing**Caution**

To prevent damage to the dual-mass flywheel when removing, the bolts -B- must not be removed with an impact wrench or similar. The bolts may only be removed by hand using conventional tools.

– Mark position of dual-mass flywheel in relation to engine.



- Rotate the dual-mass flywheel -A- so that the bolts -B- align centrally with the holes -arrows-.
- When unscrewing bolts -B-, ensure that none of the bolt heads come into contact with the dual-mass flywheel -arrows-. The flywheel will otherwise be damaged as the bolts are screwed out further.

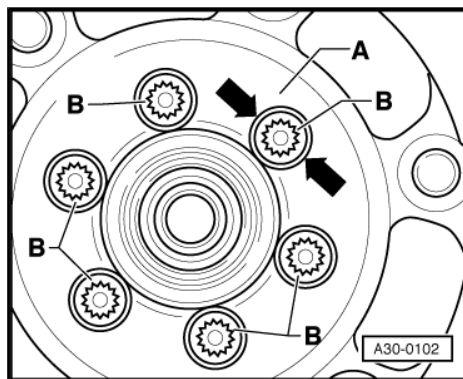

- Insert counterhold -3067- in hole on cylinder block -B-.
- Unbolt dual-mass flywheel.

Installing

Installation is carried out in the reverse order; note the following:

- Tightening torque ⇒ [page 48](#)
- Use new securing bolts.

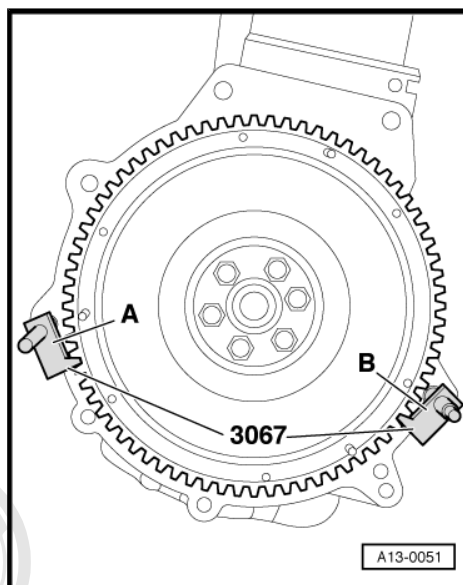

- Insert counterhold -3067- in hole on cylinder block -A-.

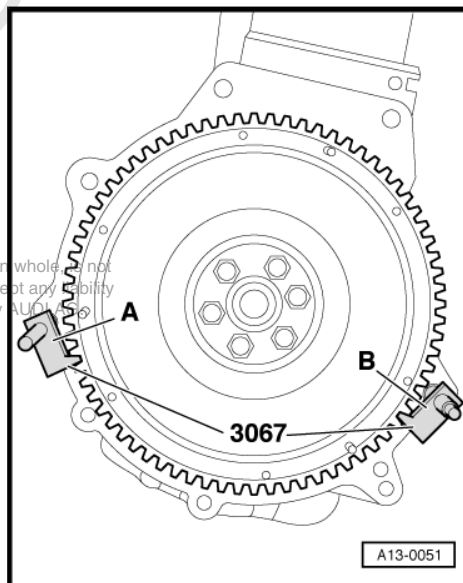

Protected by copyright. Copying for private or commercial purposes, in part or in whole, is not permitted unless authorised by AUDI AG. AUDI AG does not guarantee or accept any liability with respect to the correctness of information in this document. Copyright by AUDI AG.

2.3 Removing and installing sealing flange (rear)

Special tools and workshop equipment required

- ◆ Electric drill with plastic brush attachment
- ◆ Safety goggles

◆ Sealant ⇒ Parts catalogue

Removing

- Gearbox removed.
- Remove dual-mass flywheel ⇒ [page 49](#).
- Detach intermediate plate at sealing flange and dowel sleeves -arrows-.

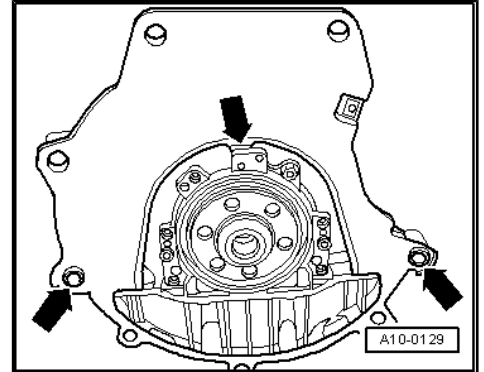

- Remove bolts -1 ... 8-.
- Pull off sealing flange (rear).

Installing

- Tightening torques ⇒ [page 48](#)



Note

Place a cloth over the exposed section of the sump.

- Carefully remove any sealant residue on the cylinder block and sump.
- Clean sealing surfaces; they must be free of oil and grease.

- Cut off tube nozzle at front marking (nozzle approx. 2 mm Ø).

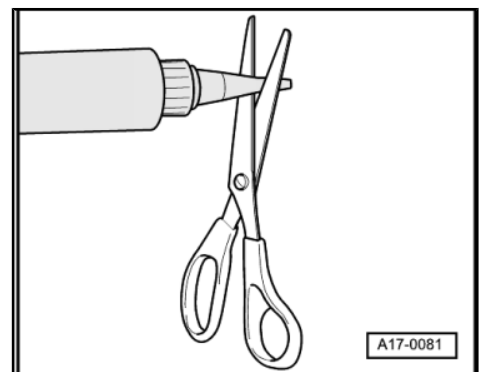
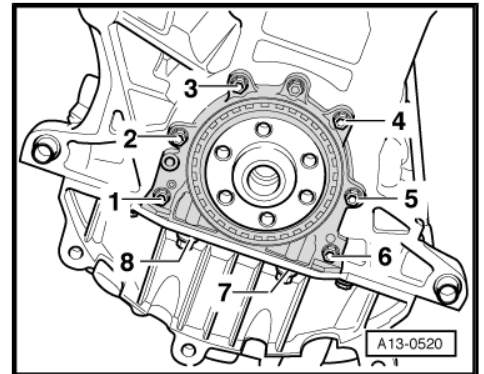

- Apply a thin bead of sealant at the edge of the joint between the cylinder block and the sump -arrows-.

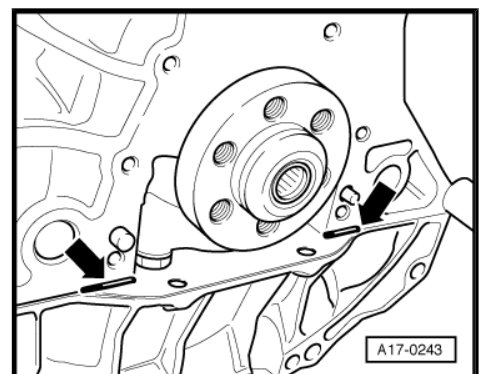

- Coat the lower sealing surface on the sealing flange lightly with sealant -hatched area-

**Caution**

Make sure oil strainer is not clogged by excess sealant.

- ◆ *The bead of sealant must not be thicker than specified.*

**Note**

The sealing flange must be installed within 5 minutes after applying sealant.

- Carefully push sealing flange -2- together with guide sleeve -1- (fitted on replacement part) onto crankshaft when installing.
- Push the sealing flange carefully onto the dowel sleeves on the cylinder block.

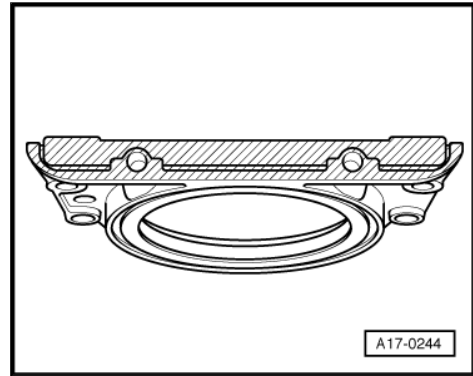

- Tighten bolts in the specified sequence:

1. Screw in bolts -1 ... 8- hand-tight.
2. Tighten bolts -1 ... 6- in diagonal sequence and in stages.
3. Tighten bolts -7 ... 8-

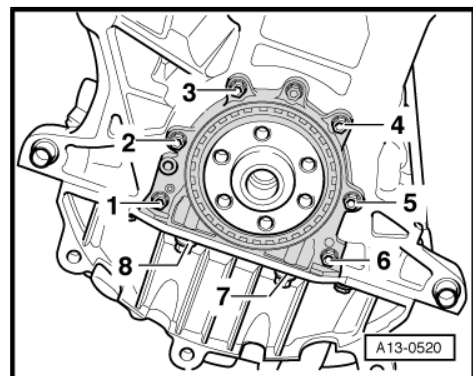
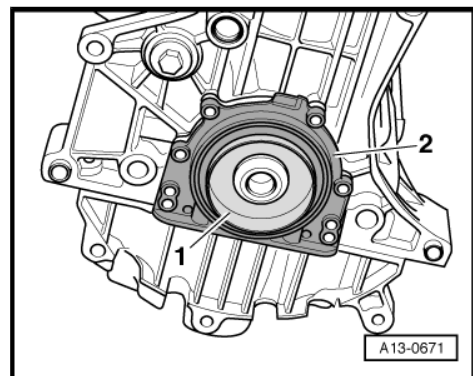
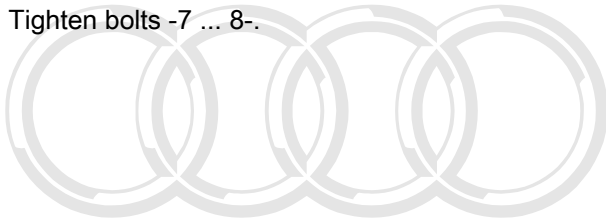

Remaining installation steps are carried out in reverse sequence; note the following:

- Fit intermediate plate on sealing flange and push onto dowel sleeves -arrows-

- **Install dual-mass flywheel ⇒ page 49.** Publication and distribution of this or any other part of this document, in part or in whole, is not permitted unless authorised by AUDI AG. AUDI AG does not guarantee or accept any liability with respect to the correctness of information in this document. Copyright by AUDI AG.

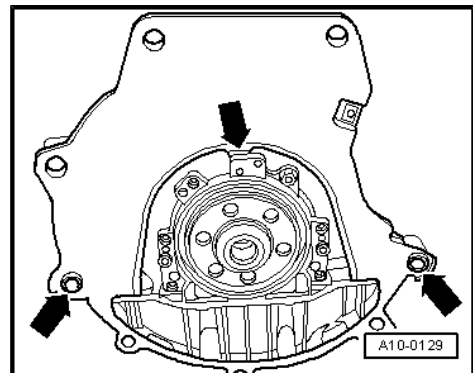

3 Crankshaft

3.1 Crankshaft - exploded view



Note

Secure engine to repair stand using engine and gearbox support
-VAS 6095- when dismantling/assembling engine ⇒ [page 20](#).

1 - Bolt

- 65 Nm + 1/4 turn (90 °) further
- Renew

2 - Bearing cap

- Bearing cap 1: Pulley end
- Bearing shell retaining lugs (cylinder block/bearing cap) must be on the same side

3 - Bolt

- 10 Nm + 1/4 turn (90 °) further
- Renew
- Sender wheel must be renewed if bolts are loosened ⇒ [page 54](#)

4 - Needle bearing

- For vehicles with manual gearbox
- Extracting and driving in ⇒ [page 57](#)

5 - Sender wheel

- For engine speed sender -G28-
- Can only be installed in one position. Holes are off-set
- Sender wheel must be renewed if bolts are loosened
- Removing and installing ⇒ [page 54](#)

6 - Crankshaft

- After removing, place it down so that the sender wheel -item 5- is not damaged and the crankshaft does not rest on the sender wheel
- Axial clearance ⇒ [page 55](#)
- Radial clearance ⇒ [page 56](#)
- Do not rotate the crankshaft when checking the radial clearance
- Crankshaft dimensions ⇒ [page 55](#)

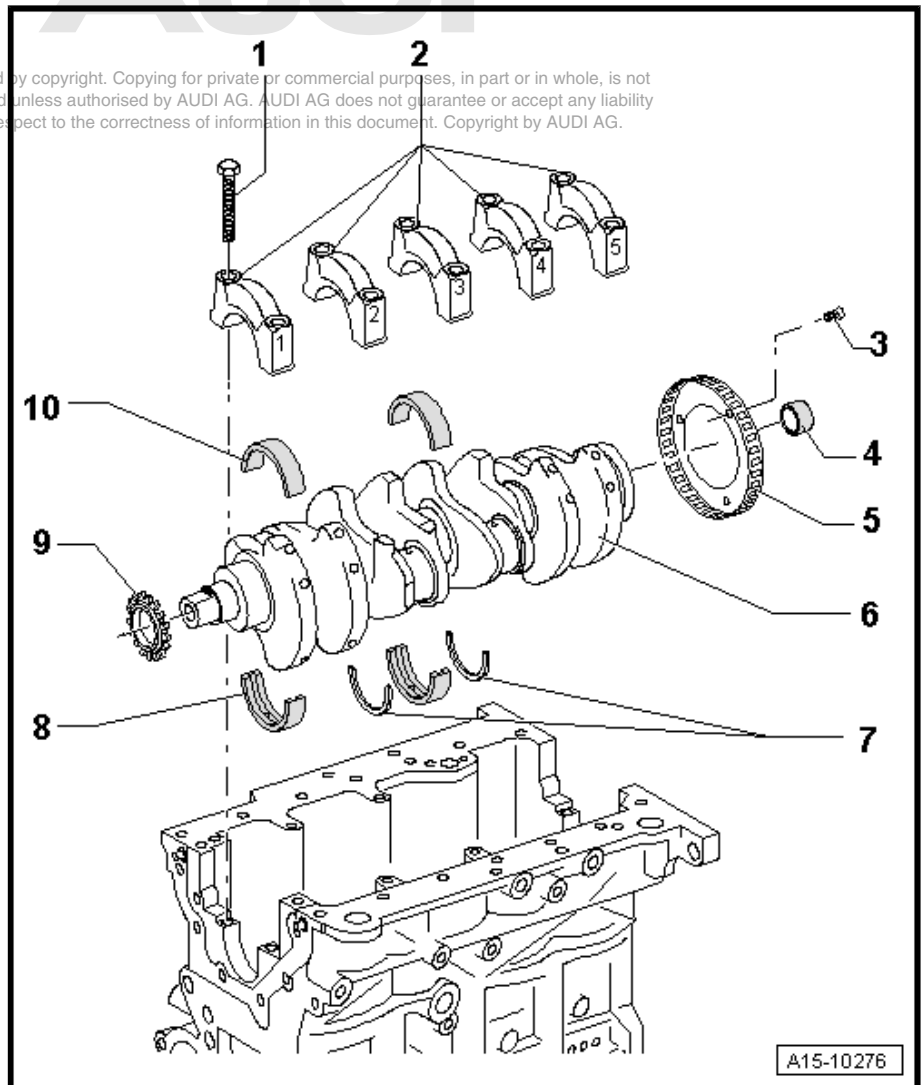

7 - Thrust washers

- For bearing No. 3

8 - Bearing shell for cylinder block

- With oil groove
- Do not interchange used bearing shells (mark positions)
- Classification for replacement parts ⇒ [page 57](#)

9 - Chain sprocket

- For oil pump chain
- Renewing ⇒ [page 58](#)

10 - Bearing shell

- Without oil groove
- Do not interchange used bearing shells (mark positions)
- The crankshaft bearing shells in the bearing caps are only supplied as spare parts with "yellow" colour-coding.

Removing and installing sender wheel

- Sender wheel -2- must always be renewed after slackening off bolts -1-.



Note

- ◆ *If the countersunk bolts are tightened a second time, the seats for the bolt heads in the sender wheel will be deformed to such an extent that the bolt heads make contact with the crankshaft -3- -arrows- and the sender wheel beneath the bolts will be loose.*

- ◆ *Sender wheel can only be fitted in one position because holes are offset.*

- Tightening torque ⇒ [page 53](#)

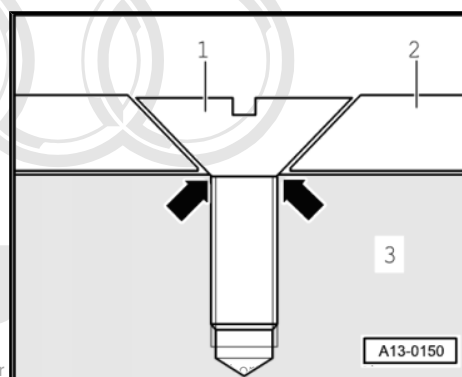

Protected by copyright. Copying for private or internal use only. Audi AG does not guarantee or accept any liability with respect to the correctness of information in this document. Copyright by AUDI AG.

Identification of top crankshaft bearings

 **Note**

Arrow points in direction of travel.

Top bearing shells of the correct thickness are allocated to the cylinder block at the factory. Coloured dots are used to identify the thickness of the bearing shells.

Letter codes on the lower sealing surface of the cylinder block indicate the thickness of the bearing shell to be fitted at each location.

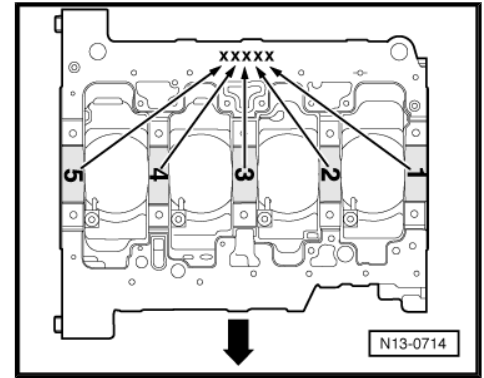

G	=	Yellow
B	=	Blue
W	=	White

 **Note**

- ◆ *Use blue bearing shells if the identification is no longer visible.*
- ◆ *The bottom crankshaft bearing shells are only supplied as replacement parts with "yellow" marking.*

3.2 Crankshaft dimensions

(in mm)

Honing dimension	Crankshaft main bearing journal Ø	Conrod journal Ø
Basic dimension	-0.017	-0.022
	54.00	47.80
1st undersize	-0.037	-0.042
	53.75	47.55
2nd undersize	-0.017	-0.022
	53.50	47.30
3rd undersize	-0.037	-0.042
	53.25	47.05
	-0.017	-0.022
	-0.037	-0.042

3.3 Measuring axial clearance of crankshaft

Special tools and workshop equipment required



Protected by copyright. Copying for private or commercial purposes, in part or in whole, is not permitted unless authorised by AUDI AG. AUDI AG does not guarantee or accept any liability with respect to the correctness of information in this document. Copyright by AUDI AG.



- ◆ Universal dial gauge bracket -VW 387-

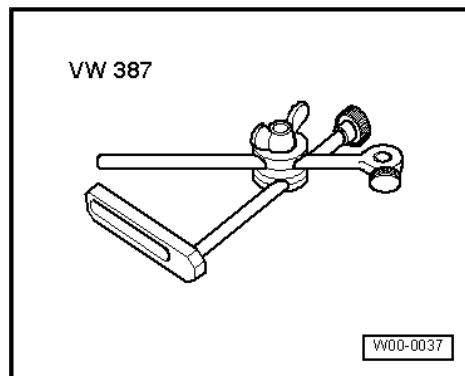

- ◆ Dial gauge -VAS 6079-

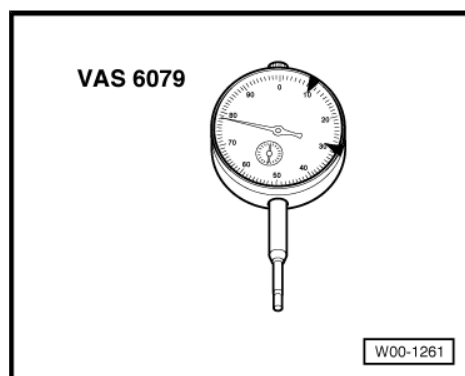

Procedure

- Bolt dial gauge -VAS 6079- with dial gauge bracket -VW 387- onto cylinder block and set it against crank web.
- Push crankshaft against dial gauge by hand and set gauge to "0".
- Push crankshaft away from dial gauge and read off value.

Axial clearance:

- New: 0.07 ... 0.23 mm.
- Wear limit: 0.30 mm.

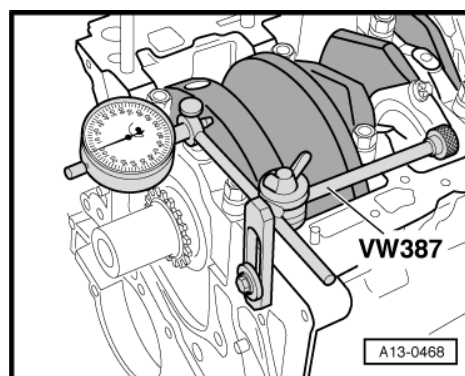

3.4 Measuring radial clearance of crankshaft

Special tools and workshop equipment required

- ◆ Plastigage

Procedure

 **Note**

- ◆ *Do not interchange used bearings.*
- ◆ *Bearing shells worn down to nickel layer must be renewed.*
- Remove main bearing caps and clean bearing caps and journals.
- Place Plastigage onto bearing journal or into bearing shells (length of Plastigage should correspond to width of bearing).
- The Plastigage must be positioned in the centre of the bearing shell.

Protected by copyright. Copying for private or commercial purposes, in part or in whole, is not permitted unless authorised by AUDI AG. AUDI AG does not guarantee or accept any liability for errors or omissions in this document. Copyright by AUDI AG.

- Fit main bearing caps and tighten to 65 Nm without rotating crankshaft.
- Remove main bearing caps once more.
- Compare width of Plastigage with measurement scale:

Radial clearance:

- New: 0.017 ... 0.037 mm.
- Wear limit: 0.15 mm.

3.5 Extracting and driving in needle bearing for crankshaft

Special tools and workshop equipment required

- ◆ Puller -T10055-

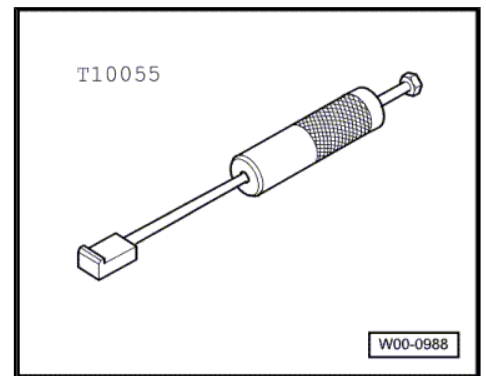

- ◆ With adapter -T10055/3- Protected by copyright. Copying for private or commercial purposes, in part or in whole, is not permitted without the written permission of AUDI AG. AUDI AG does not guarantee or accept any liability with respect to the correctness of information in this document. Copyright by AUDI AG.
- ◆ Centring mandrel -3176-

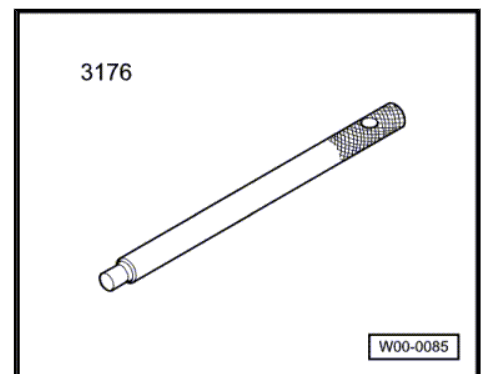

- ◆ Or drift -VW 207 C-
- ◆ Puller e.g. Kukko -21/2-

Removing

- Extract with commercially available puller e.g. Kukko -21/2-arrow-, adapter -T10055/3- and puller -T10055- .

Installing



Note

The lettering on the needle bearing must be visible when installed.

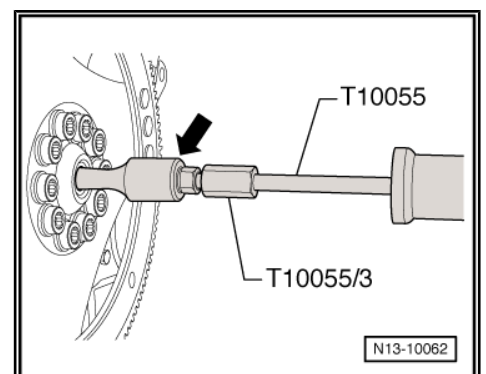



- Drive in with drift -VW 207 C- or centring mandrel -3176- .

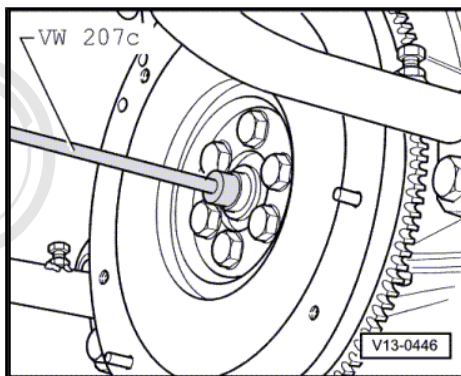

Installation depth of -a- = 2 mm

Protected by copyright. Copying for private or commercial purposes, in part or in whole, is not permitted unless authorised by AUDI AG. AUDI AG does not guarantee or accept any liability with respect to the correctness of information in this document. Copyright by AUDI AG.

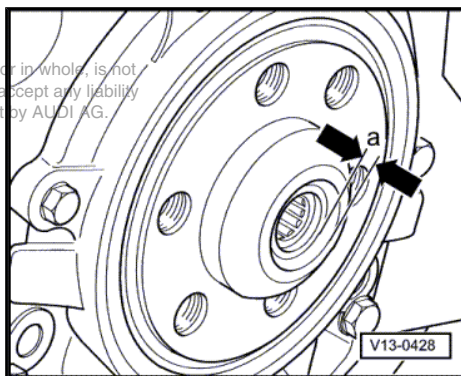

3.6 Removing and installing chain sprocket

Special tools and workshop equipment required

- ◆ Drift sleeve -30 - 100-

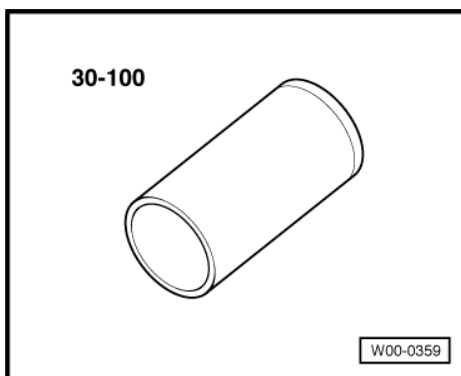

- ◆ Thrust plate -40 - 105-

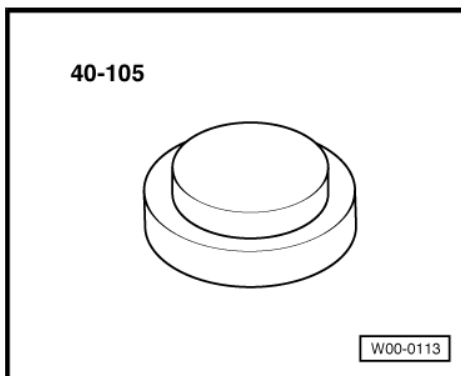

- ◆ Two-arm puller, commercially available
- ◆ Protective gloves

Removing

- Remove sump with oil pump ⇒ [page 120](#) .
- Remove front sealing flange ⇒ [page 44](#) .
- Pull chain sprocket off crankshaft with puller -2- (Kukko 44-1 or similar). Use special tool 40-105 to protect end of crankshaft.

Installing

Installation is carried out in the reverse order; note the following:



WARNING

Wear protective gloves.

- Heat chain sprocket in oven for approx. 15 minutes to 220°C.



Note

Installation position: wide collar on sprocket facing towards engine,

- Fit chain sprocket on end of crankshaft using pliers, and press onto crankshaft as far as the stop using drift sleeve -30 - 100- .
- Install sump with oil pump ⇒ [page 120](#) .

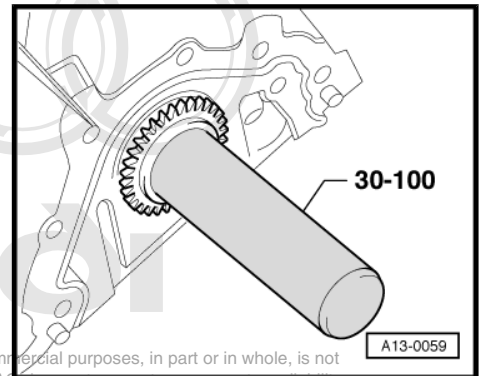
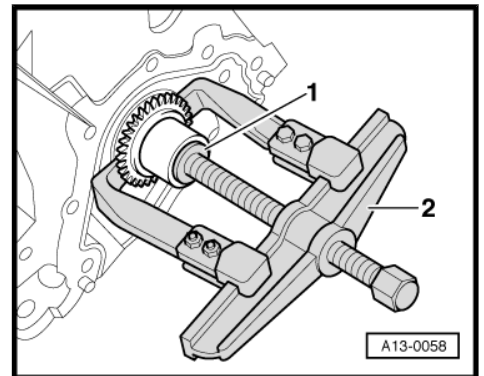

Protected by copyright. Copying for private or commercial purposes, in part or in whole, is not permitted unless authorised by AUDI AG. AUDI AG does not guarantee or accept any liability with respect to the correctness of information in this document. Copyright by AUDI AG.



4 Pistons and conrods - exploded view

1 - Conrod bolt

- 30 Nm + 1/4 turn (90°) further
- Renew
- Lubricate threads and contact surface
- Use old bolts when measuring radial clearance
- To measure radial clearance, tighten to 30 Nm but do not turn further

2 - Pressure relief valve

27 Nm

- Opening pressure: 1.6 ... 1.9 bar

3 - Oil spray jet

- For piston cooling

4 - Conrod bearing cap

- Note installation position
- Due to the cracking method used to separate the bearing cap from the conrod in manufacture, the caps only fit in one position and only on the appropriate conrod.
- Mark cylinder number -B-
- Installation position: Markings -A- face towards pulley end

5 - Bearing shells

- Upper bearing shell with oil hole for piston pin lubrication
- Installation position => [page 62](#)
- Do not interchange used bearing shells (mark positions)
- Axial clearance when new: 0.10...0.35 mm; wear limit: 0.40 mm
- Check radial clearance with Plastigage - (new): 0.02 ... 0.06 mm; wear limit: 0.09 mm. Do not turn crankshaft when measuring radial clearance

6 - Conrod

- Only renew as a complete set
- Mark cylinder number -B-
- Installation position: Markings -A- face towards pulley end
- With oil drilling for piston pin lubrication

7 - Circlip

8 - Piston pin

- If difficult to move, heat piston to approx. 60 °C
- Remove and install using drift -VW 222 A-

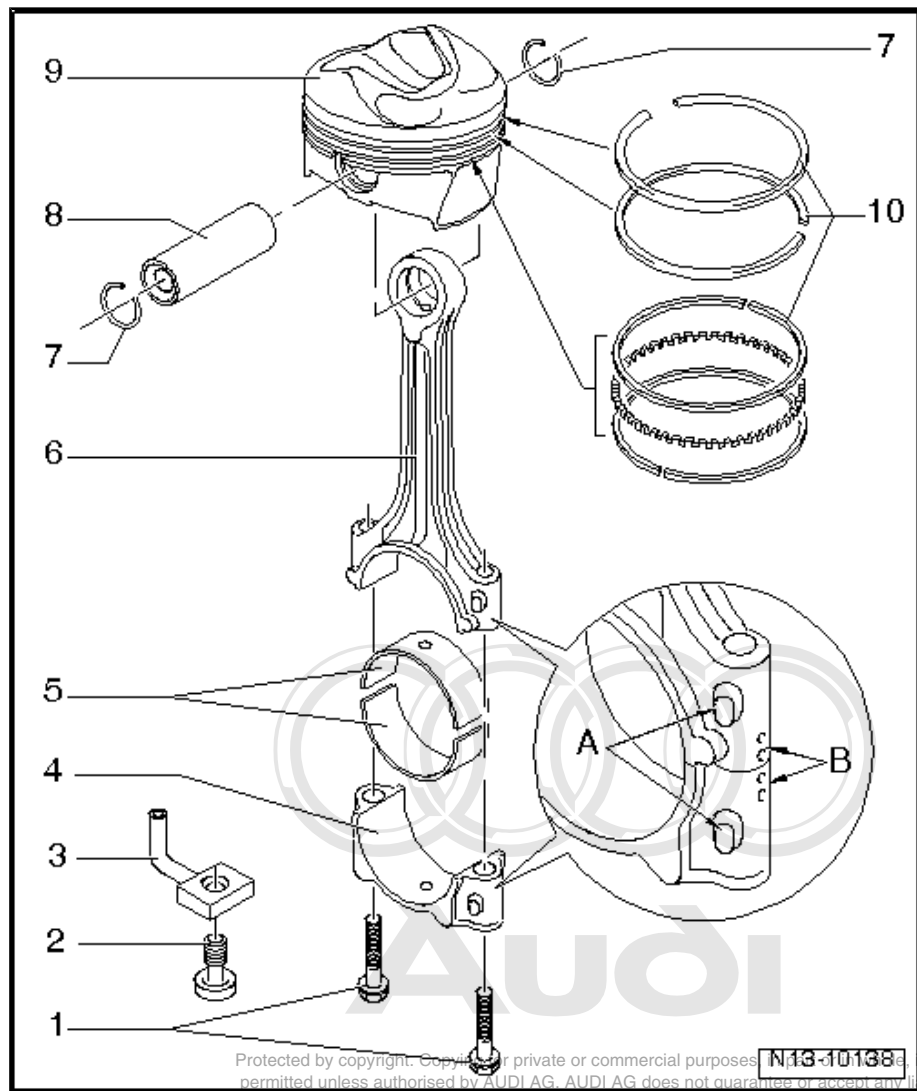

Protected by copyright. Copying for private or commercial purposes is not permitted unless authorised by AUDI AG. AUDI AG does not guarantee or accept any liability with respect to the correctness of information in this document. Copyright by AUDI AG.

9 - Piston

- Checking ⇒ [page 61](#)
- Mark installation position and cylinder number
- Arrow on piston crown points to pulley end
- Install using piston ring clamp
- Piston and cylinder dimensions ⇒ [page 62](#)
- Checking cylinder bore ⇒ [page 62](#)

10 - Piston rings

- Offset gaps by 120 °
- Use piston ring pliers to remove and install
- "TOP" must face towards piston crown
- Checking ring gap ⇒ [page 61](#)
- Checking ring-to-groove clearance ⇒ [page 61](#)

Checking piston ring gap

- Insert ring at right angle to cylinder wall from above and push down into lower cylinder opening approx. 15 mm from bottom of cylinder. Use a piston without rings to push ring into bore.

Piston ring Dimensions in mm	New	Wear limit
Compression ring	0.20...0.40	0.8
Oil scraper ring	0.25...0.50	0.8

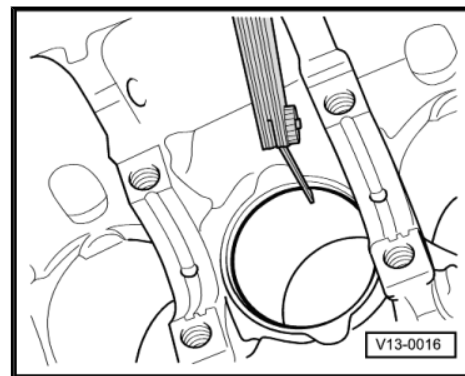

Checking ring-to-groove clearance

- Clean groove in piston before checking clearance.

Piston ring Dimensions in mm	New	Wear limit
Compression ring	0.06...0.09	0.20
Oil scraper ring	0.03...0.06	0.15

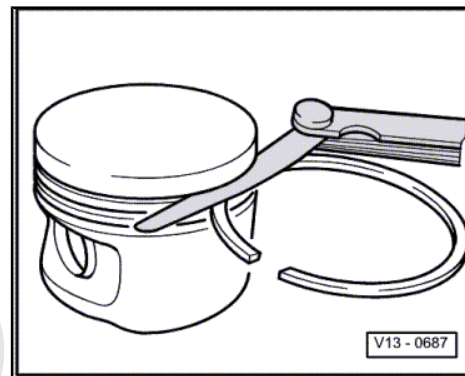

Checking piston

- Measure approx. 10 mm from the bottom edge, perpendicular to the piston pin axis.
- ◆ Deviation from nominal dimension: max. 0.04 mm

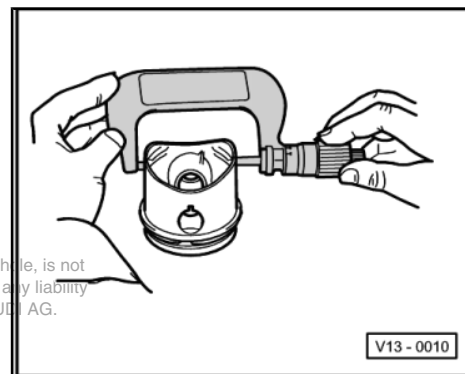

Protected by copyright. Copying for private or commercial purposes, in part or in whole, is not permitted unless authorised by AUDI AG. AUDI AG does not guarantee or accept any liability with respect to the correctness of information in this document. Copyright by AUDI AG.



Checking cylinder bore

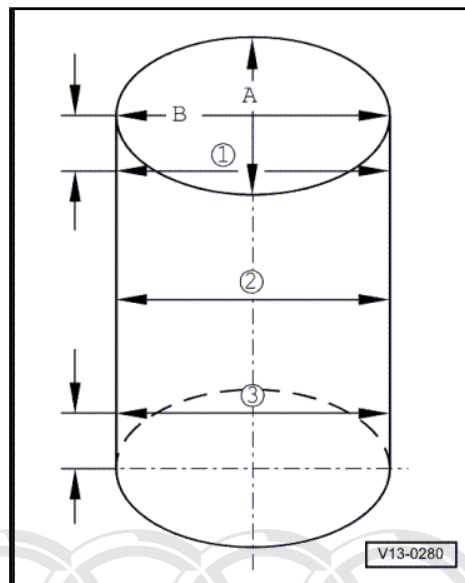

Special tools and workshop equipment required

- ◆ Cylinder dial gauge 50...100 mm
- Take measurements at 3 positions in both lateral direction -A- and longitudinal direction -B-.
- ◆ Deviation from nominal dimension: max. 0.08 mm

Installation position of bearing shell

Bearing shell -1- with oil drilling -arrow- for conrod.

Bearing shell -2- without oil drilling for conrod bearing cap.

- Position bearing shells in centre of conrod and conrod bearing cap when fitting.

Dimension -a- must be identical on both sides.

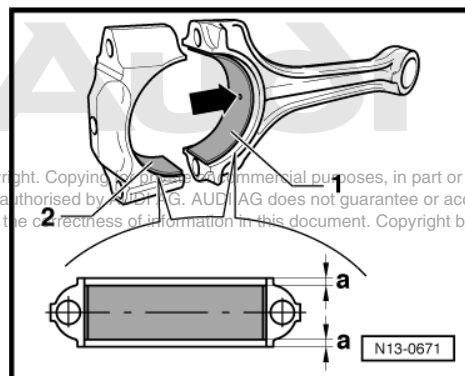

Protected by copyright. Copying or distribution for commercial purposes, in part or in whole, is not permitted unless authorised by Audi AG. Audi AG does not guarantee or accept any liability with respect to the correctness of information in this document. Copyright by Audi AG.

4.1 Piston and cylinder dimensions

Honing dimension	Piston Ø	Cylinder bore Ø
Basic dimension mm	82.465 ¹⁾	82.51
<ul style="list-style-type: none"> • ¹⁾ Dimension not including graphite coating (thickness 0.02 mm). The graphite coating wears down in service. 		

15 – Cylinder head, valve gear

1 Toothed belt drive

1.1 Toothed belt drive - exploded view

Mark the rotation direction of the toothed belt with chalk or felt-tip pen before removing. If the belt runs in the opposite direction when it is refitted, this can cause breakage.

1 - Bolt

- 10 Nm
- Apply locking fluid when fitting
- Locking fluid ⇒ Parts catalogue

2 - Toothed belt cover (top)

3 - Bolt

- 50 Nm + turn 180° further
- Renew
- Use counterhold tool -3036- when loosening and tightening ⇒ [page 64](#)

4 - Camshaft sprocket

- Remove toothed belt prior to removing and installing ⇒ [page 66](#)
- Installation position fixed by Woodruff key ⇒ [Item 7 \(page 63\)](#)
- Detaching camshaft sprocket ⇒ [page 65](#)

5 - Bolt

- 10 Nm
- Apply locking fluid when fitting
- Locking fluid ⇒ Parts catalogue

6 - Toothed belt cover (rear)

7 - Woodruff key

- Check for firm attachment

8 - Nut

- 25 Nm

9 - Semi-automatic tensioning roller

10 - Coolant pump

- Removing and installing ⇒ [page 155](#)

11 - O-ring

- Renew

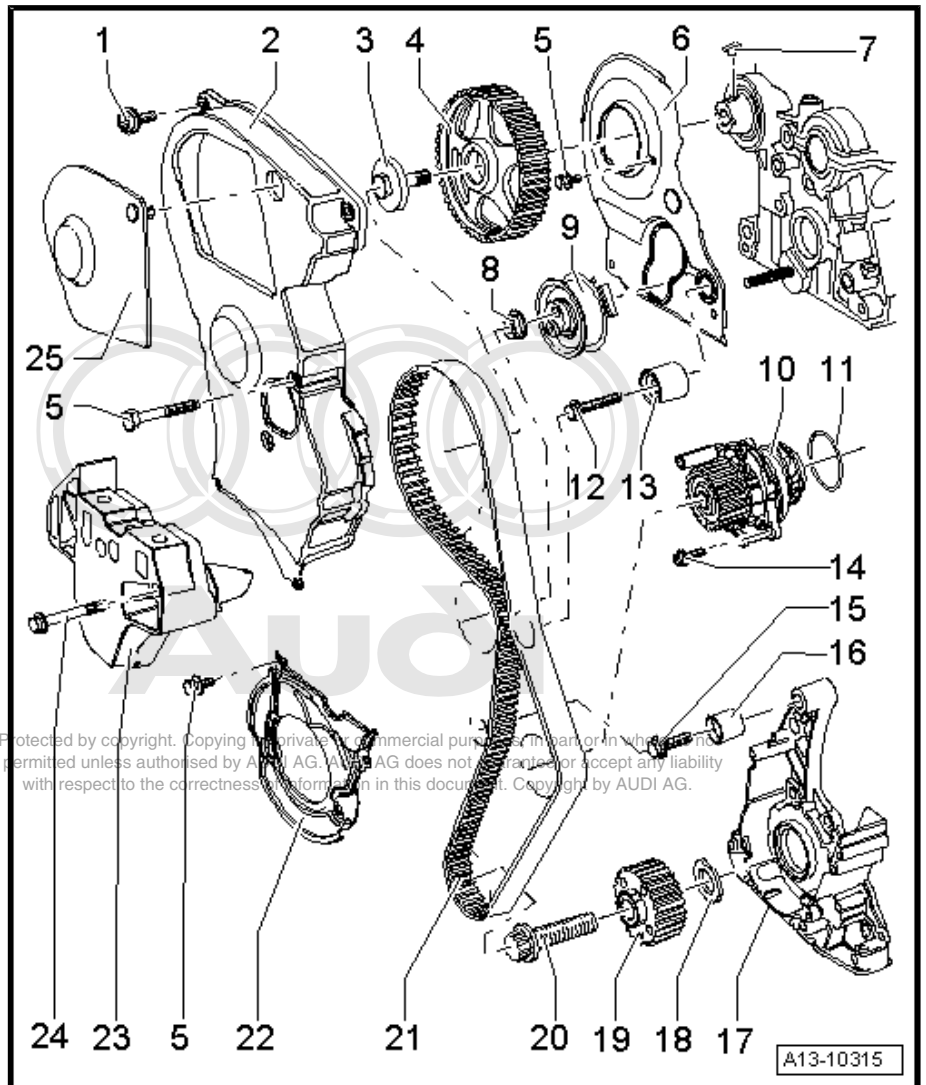



12 - Bolt

- 25 Nm

13 - Damper wheel

14 - Bolt

- 15 Nm

15 - Bolt

- 35 Nm

16 - Damper wheel

17 - Sealing flange

- Removing and installing ⇒ [page 44](#)

18 - Diamond-coated washer for toothed belt sprocket

- Renew washer if toothed belt sprocket is removed

19 - Crankshaft sprocket

- Contact surface between sprocket and crankshaft must be free of oil
- Can only be installed in one position

20 - Bolt

- 90 Nm + 90° (1/4 turn) further
- Renew
- Do not lubricate with oil
- Attaching counterhold tool 3415 ⇒ [page 65](#)

21 - Toothed belt

- Before removing, mark direction of rotation with chalk or felt-tipped pen
- Check for wear
- Removing ⇒ [page 66](#)
- Installing (adjusting valve timing) ⇒ [page 66](#)

22 - Toothed belt cover (bottom)

23 - Engine support

- Removing ⇒ Removing and installing toothed belt ⇒ [page 66](#)
- Installing ⇒ [page 65](#)

24 - Bolt

- 45 Nm
- Observe correct tightening sequence ⇒ [page 75](#)

25 - Cap for toothed belt cover

Loosening camshaft sprocket

- Use counterhold -3036- when loosening and tightening central bolt.

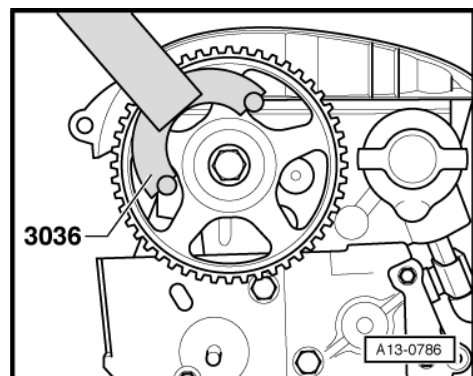

Detaching camshaft sprocket

- Use two-arm puller -T40001- with claws T40001/6 and T40001/7 to detach camshaft sprocket.

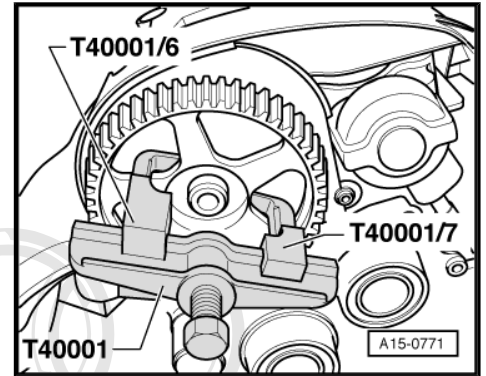
**Removing and installing crankshaft sprocket**

- Use counterhold -3415- when loosening and tightening central bolt.

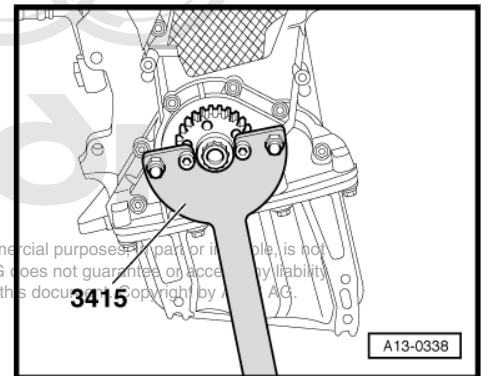

Protected by copyright. Copying for private or commercial purposes in part or in whole is not permitted unless authorised by AUDI AG. AUDI AG does not guarantee or accept any liability with respect to the correctness of information in this document. Copyright by AUDI AG.

Installing engine support

- Fit bolts -1 ... 3- and tighten hand-tight initially.
- Then tighten bolts, tightening torque ⇒ [page 63](#) .

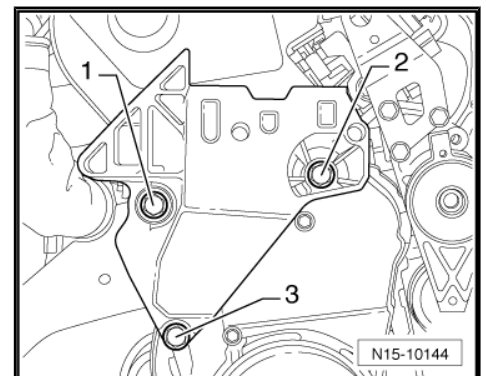



1.2 Removing and installing toothed belt

Special tools and workshop equipment required

- ◆ Support bracket -10 - 222 A-
- ◆ 2x spindle -10 - 222 A /11-
- ◆ Adapter -10 - 222 A /20- (2x)
- ◆ Hooks -10 - 222 A /2-
- ◆ Engine support bracket (basic set) -T40091-
- ◆ Engine support bracket (supplementary set) - T40093- with -T40093/3-2- and -T40093/3-3-

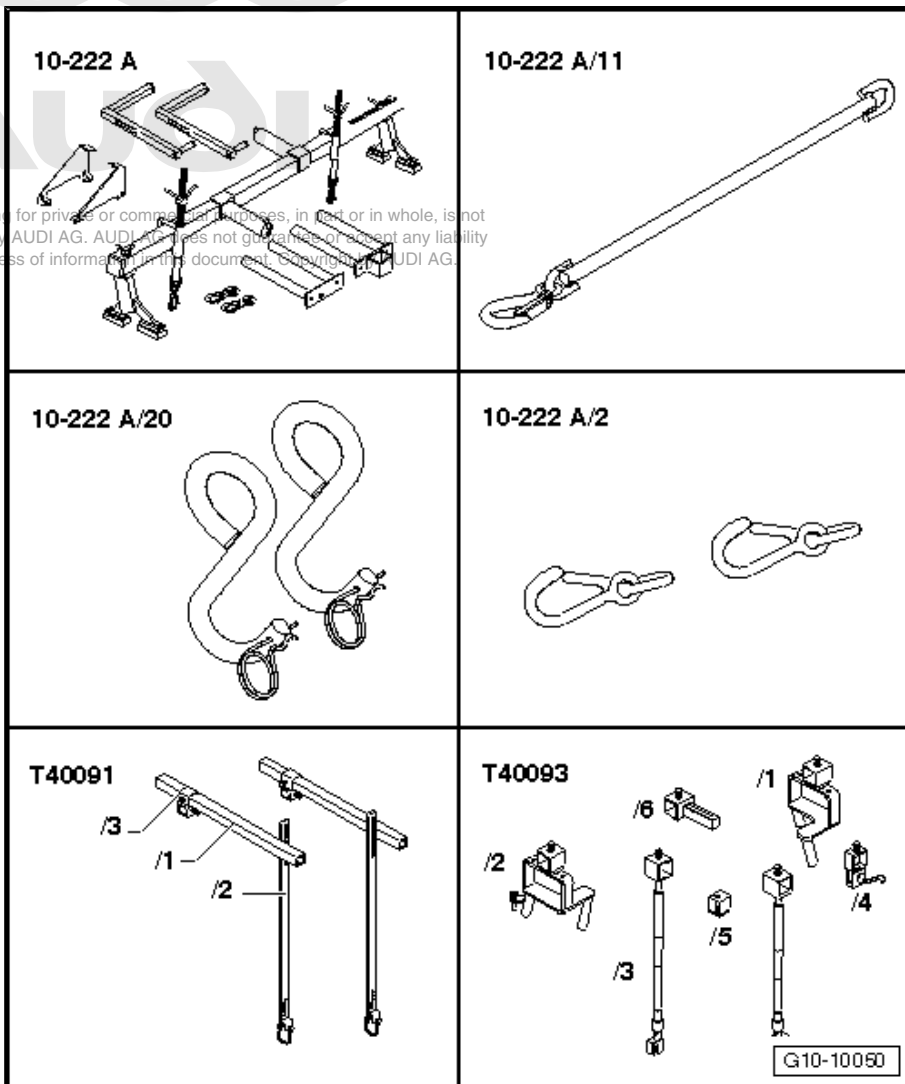

Pin wrench -T10020-

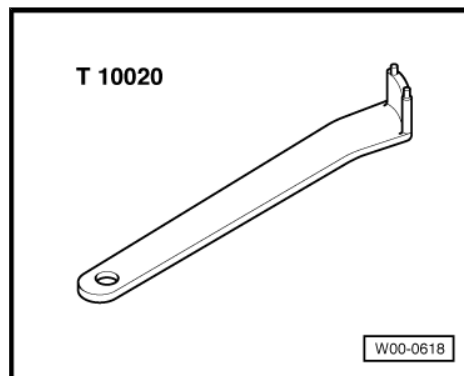

Locking pin -T10060A-
Removing

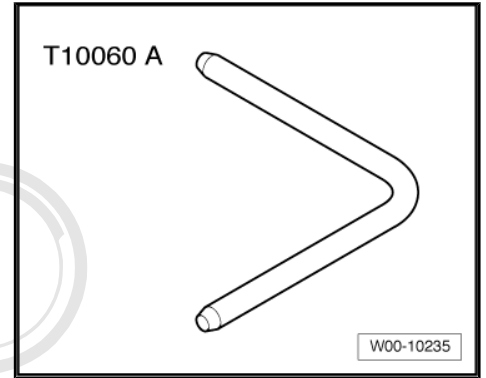

- Unplug electrical connector at air mass meter -G70- -3-.
- Open clamps -1 and 2- and disconnect air intake hose from air mass meter.
- Detach air intake connection at lock carrier -4-.
- Pull off engine cover panel.



WARNING

Hot steam/hot coolant may escape when opening expansion tank. Cover cap with cloth and open carefully.

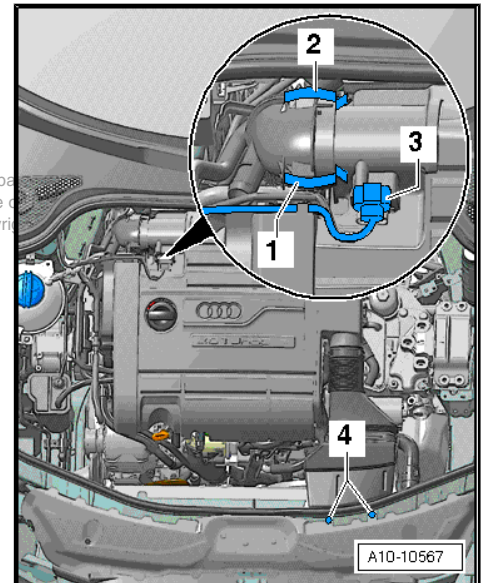

- Open filler cap on coolant expansion tank

- Remove centre noise insulation -fasteners 1 ... 4-.

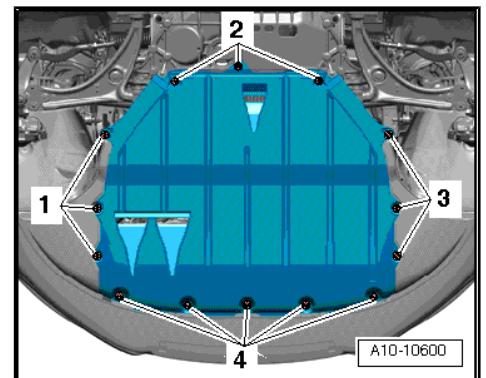

- Remove right noise insulation -arrows-.

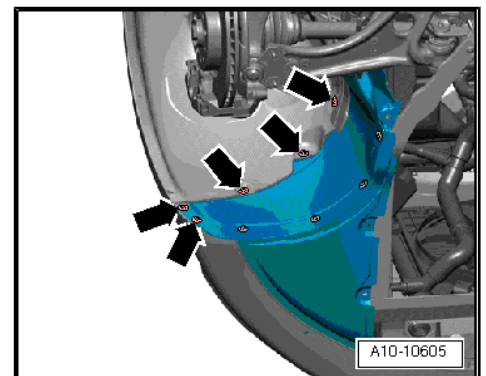



- Remove noise insulation frame -arrow-.

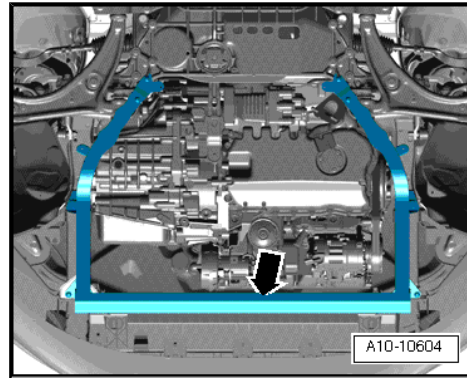

- Unscrew bolts -arrows- and remove charge air pipe together with hoses.



Audi

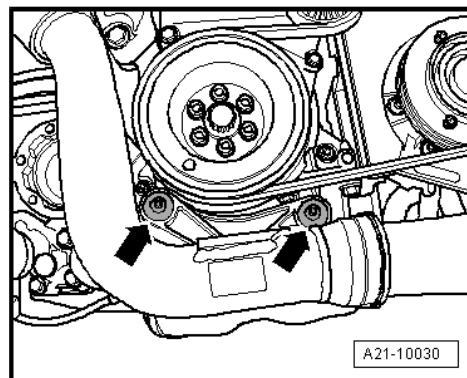

- Unscrew bolts -1 ... 3- and remove pendulum support.
- Drain off coolant => [page 147](#)

Protected by copyright. Copying for private or commercial purposes, in part or in whole, is not permitted without the express consent of AUDI AG. AUDI AG does not guarantee or accept any liability with respect to the correctness of information in this document. Copyright by AUDI AG.

⚠ WARNING

Fuel supply line is pressurised. Wear safety goggles and protective clothing to avoid possible injury and skin contact. Before removing from hose connection wrap a cloth around the connection. Then release pressure by carefully pulling hose off connection.

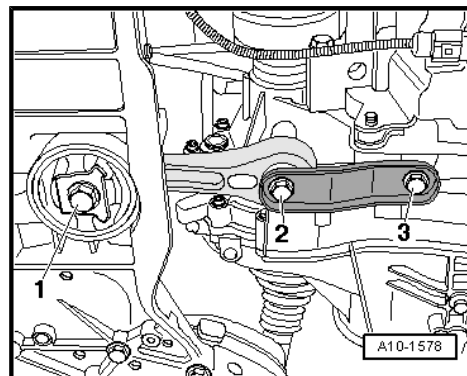

- Mark fuel line -1- and line going to ACF -2-.
- Disconnect fuel line -1-.
- Disconnect ACF line -2-.
- Disconnect ACF line going to tank -3-.
- Lift out ACF in -direction of arrow-.

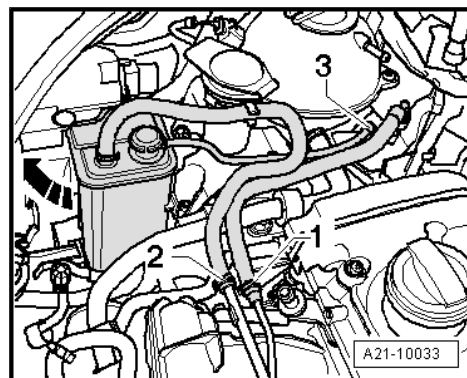

- Detach the coolant hose at the bracket -1-.
- Remove bracket for activated charcoal filter -arrows-.

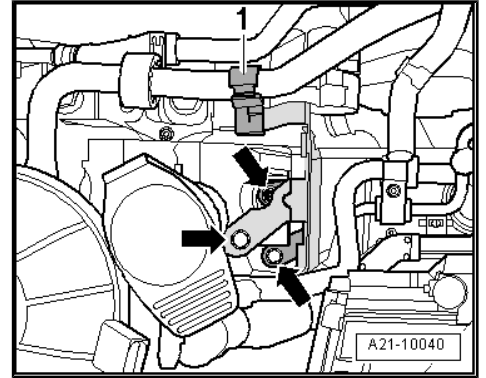

- Unbolt filler neck for windscreen washer reservoir -1-.
- Remove retaining clip; to do so, unscrew bolts -2 and 3-.

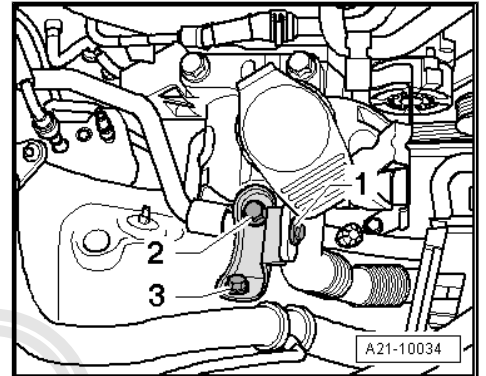

- Unplug electrical connector -1- from coolant level indicator.
- Detach coolant expansion tank -arrows-.

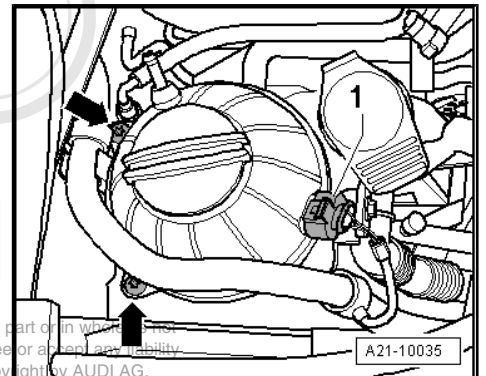

Protected by copyright. Copying for private or commercial purposes, in part or in whole, is not permitted unless authorised by AUDI AG. AUDI AG does not guarantee or accept any liability with respect to the correctness of information in this document. Copyright by AUDI AG

- Disconnect coolant pipe -arrow-.
- Remove poly-V belt and remove locking pin -T10060A- => [page 33](#) .
- Remove bracket for activated charcoal filter.

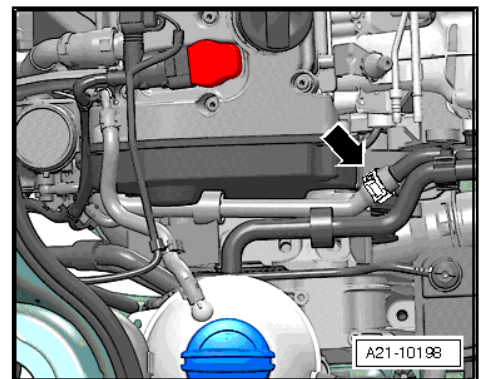



- Disconnect coolant pipe -arrows-.

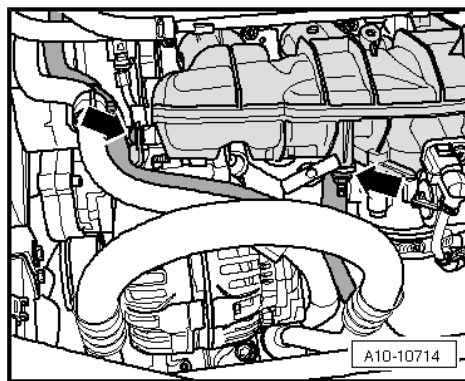

- Detach gear selector cable -arrow-.

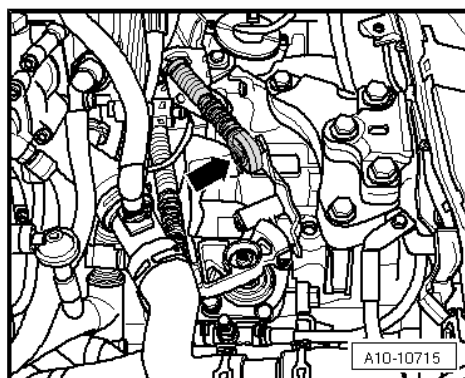

- Position support bracket -10 - 222 A- on bolted flanges of wing panels using the following tools:

- ◆ 2x Rack -10 - 222 A /1-
- ◆ Support bracket -10 - 222 A-
- ◆ Spindle -10 - 222 A /11- (spindle faces front)
- ◆ Hooks -10 - 222 A /2-
- ◆ Adapter -10 - 222 A /20-
- ◆ Connecting piece -T40091/3- (2x)

- Attach spindle -10 - 222 A /11- with hook -10 - 222 A /2- and adapter -10 - 222 A /20- to gearbox lifting eye.
- Tighten spindle slightly to take up weight of engine/gearbox assembly.

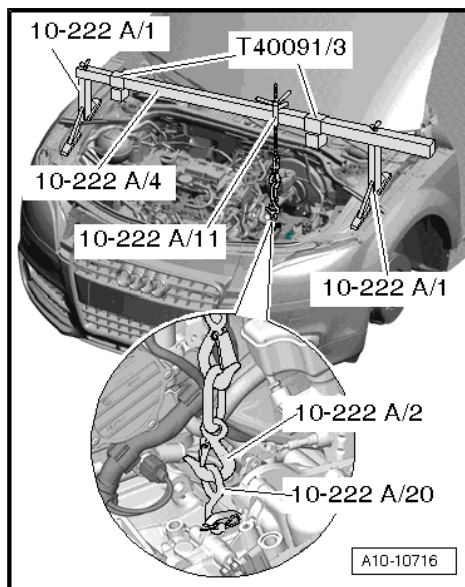

Protected by copyright. Copying for private or commercial purposes, in part or in whole, is not permitted unless authorised by AUDI AG. AUDI AG does not guarantee or accept any liability with respect to the correctness of information in this document. Copyright by AUDI AG.

- Fit adapter -T40093/3-2- (left-side) and -T40093/3-3- (right-side) to supports -T40093/3- .
- Unbolt earth wire from longitudinal member (left-side).
- Remove connecting bolt for front section of longitudinal member on left and right.
- Secure adapters to longitudinal members using the removed bolts -arrow-.

 **Note**

The illustration shows the left side of the vehicle.

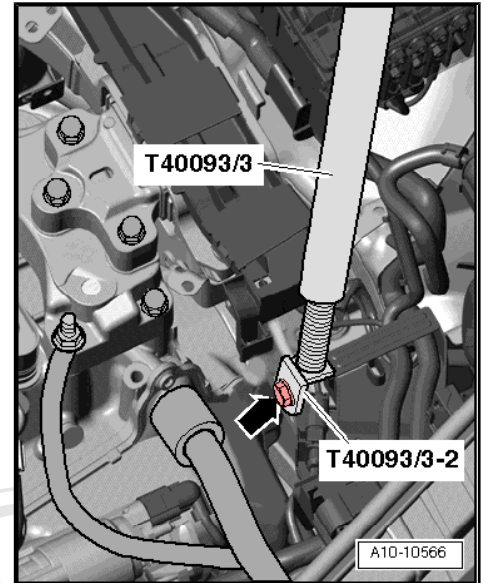

- Fit square-section pipes -T40091/1- with connecting pieces -T40093/4- into connecting pieces -T40091/3- and supports -T40093/3-- as shown in illustration.

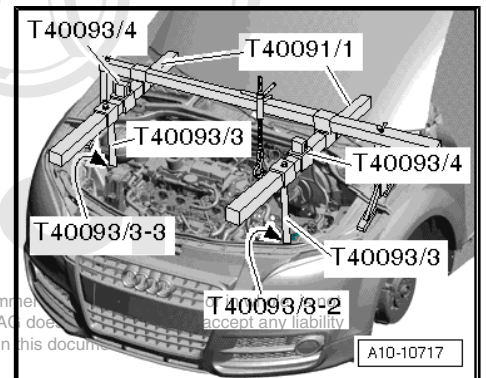

Protected by copyright. Copying for private or commercial use is not permitted unless authorised by AUDI AG. AUDI AG does not accept any liability with respect to the correctness of information in this document.

- Push support -T40091/2- with sliding support -T40093/5- into the two connecting pieces -T40093/4- .



WARNING

Accident risk from loose components of support bracket.

- ◆ *Secure support -T10091/2- with pins and split pins of connecting pieces -T40093/4- .*
- ◆ *Secure connecting pieces and supports with clamping bolts.*

- Fit spindle -10 - 222 A /11- with adapter -10 - 222 A /20- onto sliding support and onto engine lifting eye.
- Take up weight of engine/gearbox assembly by evenly tightening two spindles.

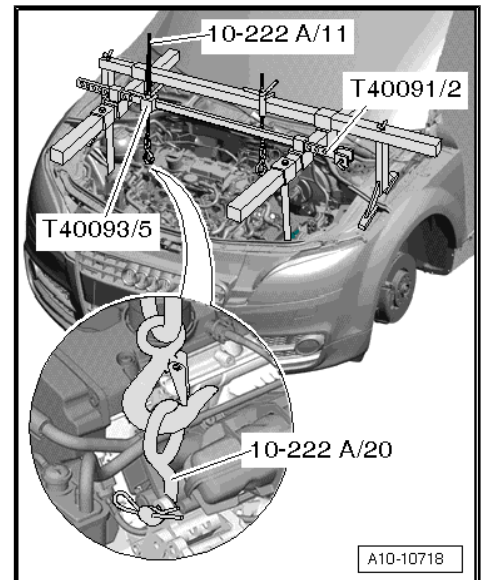



- Remove securing bolts from assembly mounting/engine support -arrows- and remove complete assembly mounting.



Caution

When raising engine with support bracket -10-222A-, ensure that components/hoses are not damaged, strained or torn off.

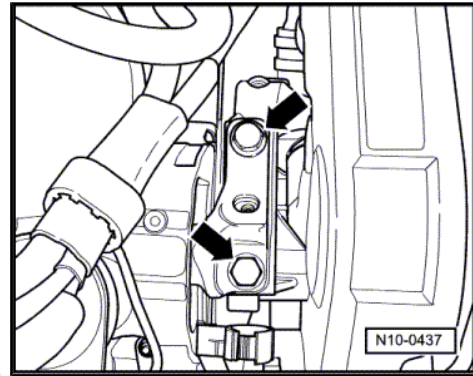

- Raise engine with support bracket -10-222A- until it is possible to loosen and remove the two top bolts -1 and 2- securing the engine support.

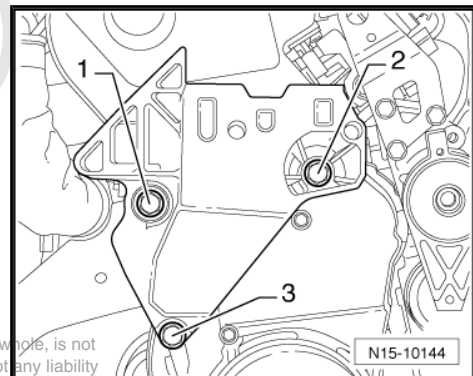

Protected by copyright. Copying for private or commercial purposes, in part or in whole, is not permitted unless authorised by AUDI AG. AUDI AG does not guarantee or accept any liability with respect to the correctness of information in this document. Copyright by AUDI AG.

- Set camshaft sprocket to TDC marking by turning crankshaft. Marking on camshaft sprocket must align with arrow on toothed belt cover.

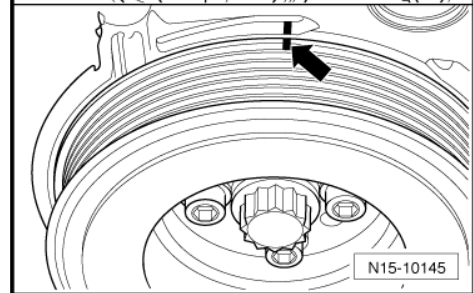
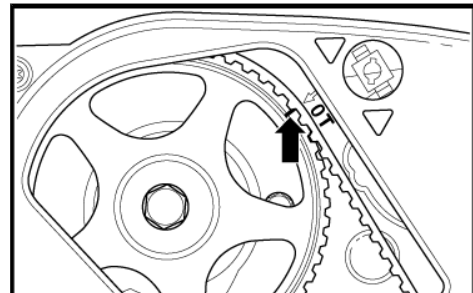

- Remove vibration damper / pulley.

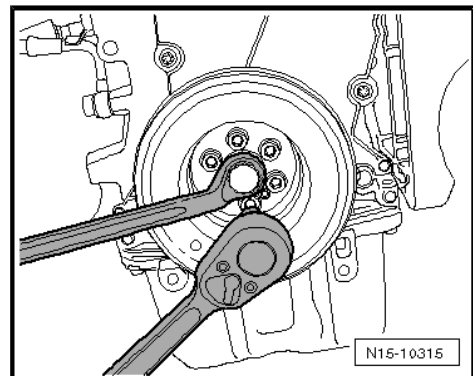

- Unscrew bolts from toothed belt cover (bottom) -arrows-.

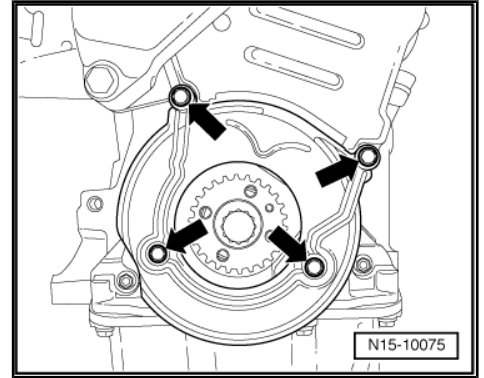

- Unscrew the bottom bolt -3- and remove engine support from below.

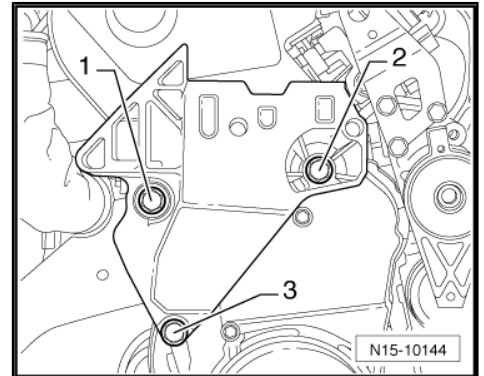

- Unscrew remaining toothed belt cover bolts -arrows- and remove toothed belt cover from engine.
- Mark direction of rotation of toothed belt.
- Loosen tensioning roller and remove toothed belt.
- Turn crankshaft back slightly.

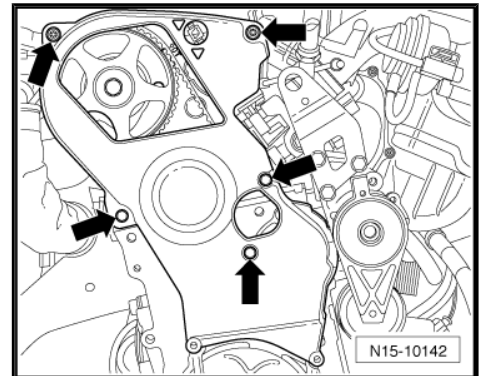

Installing

- Tightening torques ⇒ [page 63](#)

Note

- ◆ *When turning the camshaft, the crankshaft must not be at TDC. Otherwise, there is a risk of damage to valves and piston crowns.*
- ◆ *The engine must be no more than warm to touch.*
- Fit toothed belt on crankshaft sprocket (note rotation direction).
- Secure toothed belt cover (bottom section) with the two bolts at the bottom.
- Install vibration damper with new bolts.



- Turn crankshaft and camshaft to TDC No. 1 cylinder -arrows-



- Fit toothed belt in the sequence: tensioning roller, camshaft sprocket, coolant pump, and last onto idler roller, arrow.

This document, including all rights reserved, is not permitted unless authorised by AUDI AG. AUDI AG does not guarantee or accept any liability with respect to the correctness of information in this document. Copyright by AUDI AG.

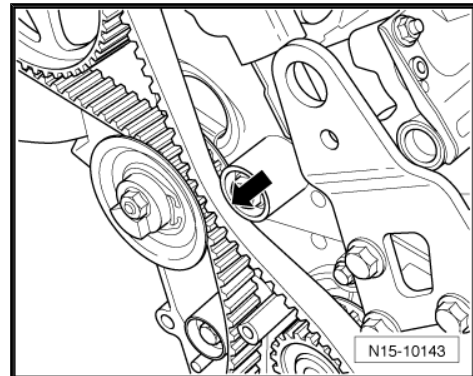
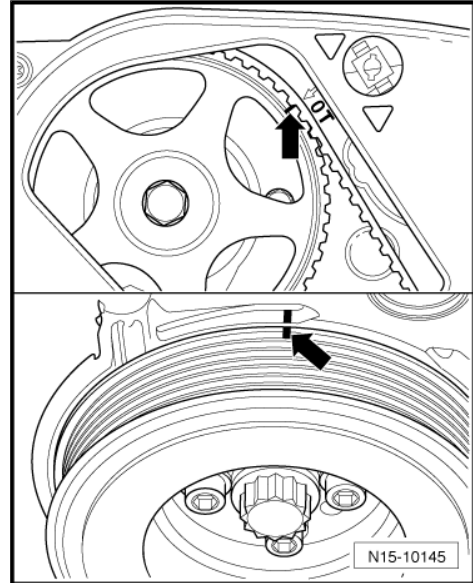

Note

Check tensioning roller is seated correctly in cylinder head.

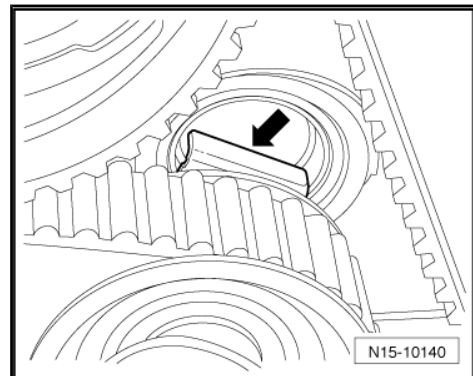

- Tension toothed belt. To do so, turn hexagon key at the eccentric adjuster clockwise (direction of arrow) until the notch is above the indicator.
- Then release tension on toothed belt.
- Now tension toothed belt until the notch and the indicator are aligned.
- Tighten securing nut
- Turn crankshaft two turns in direction of engine rotation and set again to TDC. Make sure that the engine is rotated without stopping during the final 45° (1/8 turn).
- Check tension of toothed belt again. Specification: indicator and notch must align.

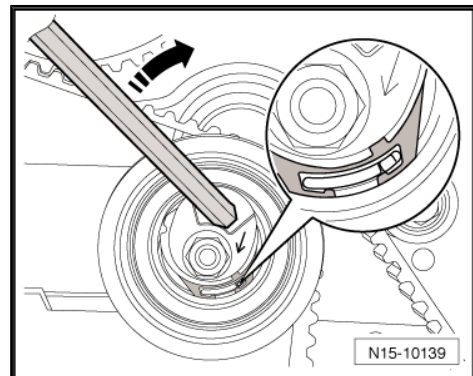

- Check valve timing again.

If the markings do not align:

- Repeat adjustment of valve timing.

If the markings align:

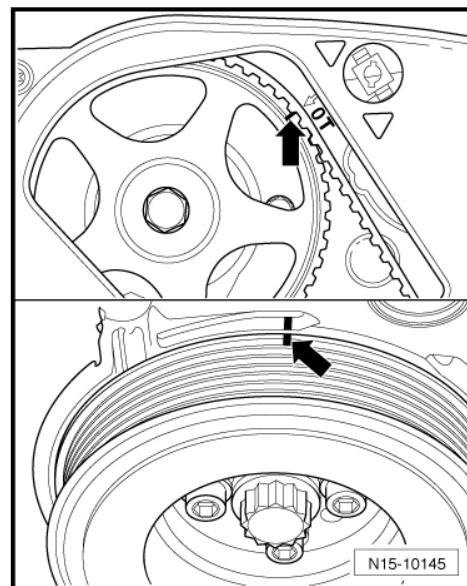

- Install toothed belt cover -arrows-.

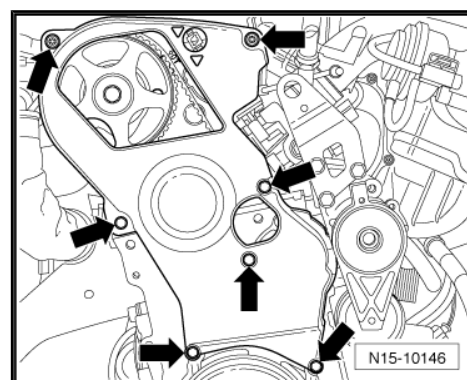

Note

Note different bolt lengths. Bolt -3- is approx. 25 mm shorter than bolts -1 and 2-.

- Insert bottom securing bolt -3- in engine support.
- Install engine support on cylinder block from below and tighten bolt finger-tight.
- Raise engine with support bracket -10-222A- until it is possible to screw in the two top bolts -1 and 2-.
- Tighten all bolts.
- Lower the engine down to installation position.
- Install complete assembly mounting for engine.

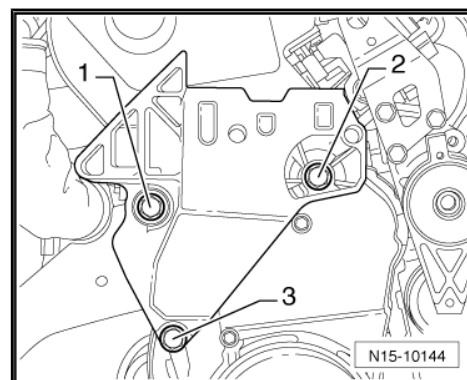

Audi

Protected by copyright. Copying for private or commercial purposes, in part or in whole, is not permitted unless authorised by AUDI AG. AUDI AG does not guarantee or accept any liability with respect to the correctness of information in this document. Copyright by AUDI AG.



- Secure assembly mounting for engine to engine support -arrows-; to do so, bring surfaces into contact using support bracket -10-222A- .
- Adjust engine mountings ⇒ [page 27](#) .
- Attach fuel hoses onto connections. Make sure plug-in connectors are properly secured.
- Installing air pipes with connectors ⇒ [page 164](#)
- Install coolant expansion tank.
- Fit noise insulation.
- Fit engine cover panel.
- Install vibration damper ⇒ [page 38](#) .
- Install poly V-belt ⇒ [page 33](#) .

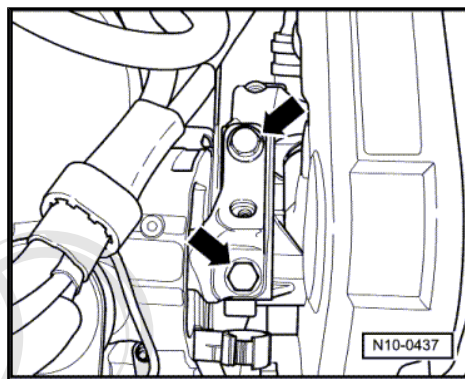

Audi

Protected by copyright. Copying for private or commercial purposes, in part or in whole, is not permitted unless authorised by AUDI AG. AUDI AG does not guarantee or accept any liability with respect to the correctness of information in this document. Copyright by AUDI AG.

2 Cylinder head

2.1 Cylinder head - exploded view

Note

- ◆ Renew the cylinder head bolts.
- ◆ On assembly, renew oil seals and gaskets as well as self-locking nuts and bolts that are tightened by turning through to a specified angle.
- ◆ When installing an exchange cylinder head with fitted camshafts, oil the contact surfaces between the roller rocker fingers and cams.
- ◆ The plastic protectors fitted to protect the open valves must only be removed immediately before fitting the cylinder head.
- ◆ When fitting a new cylinder head or cylinder head gasket, drain off all the old coolant and refill with new coolant.

1 - Bolt

- Tightening sequence
⇒ [page 78](#)

2 - Cylinder head cover

- Removing and installing
⇒ [page 82](#)
- Tightening sequence
⇒ [page 78](#)

3 - Gasket

- Renew if damaged or leaking

4 - Valve housing

5 - Oil filler cap

6 - Seal

- Renew if damaged or leaking

7 - Bolt

- 4 Nm

8 - Gasket for cylinder head cover

- Renew if damaged or leaking

9 - Exhauster pump

10 - Bolt

- 4 Nm

11 - Inlet camshaft control valve 1-N205-

- Removing ⇒ [page 80](#)

12 - Seal

- Renew

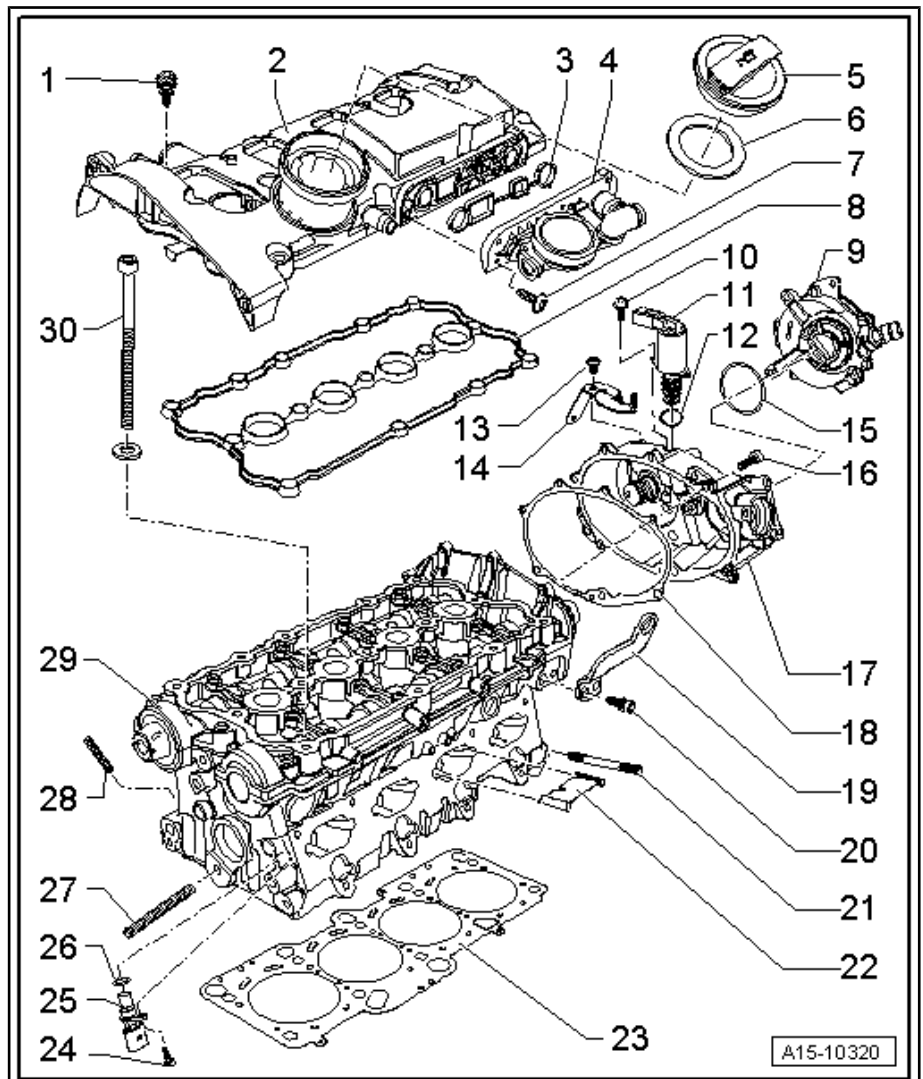

**13 - Bolt**

- 10 Nm

14 - Cable retainer**15 - Seal**

- Renew if damaged or leaking

16 - Bolt

- 10 Nm

17 - Housing**18 - Gasket**

- Renew

19 - Transport plate**20 - Bolt**

- 25 Nm

21 - Stud for intake manifold

- 10 Nm

22 - Separating plate**23 - Cylinder head gasket**

- Renew
- Check installation position: Part No. towards cylinder head
- If renewed, refill system with fresh coolant

24 - Bolt

- 10 Nm

25 - Hall sender -G40-**26 - Seal****27 - Stud for tensioning roller**

- 10 Nm

28 - Stud for exhaust manifold

- 20 Nm

29 - Cylinder head

- Checking for distortion ⇒ [page 79](#)

30 - Cylinder head bolt

- Renew
- Note correct sequence when loosening ⇒ [page 79](#)
- Observe correct tightening sequence ⇒ [page 79](#)

Tightening sequence for cylinder head cover

– Proceed as follows:

1. Screw in bolts -1 ... 14- hand-tight.
2. Tighten bolts -1 ... 14- in diagonal sequence to 10 Nm.

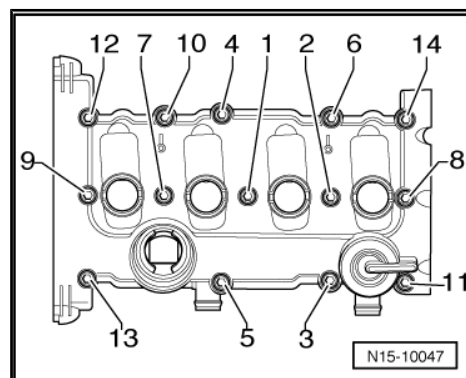

Loosening cylinder head bolts

- Loosen cylinder head bolts in the sequence indicated and remove.

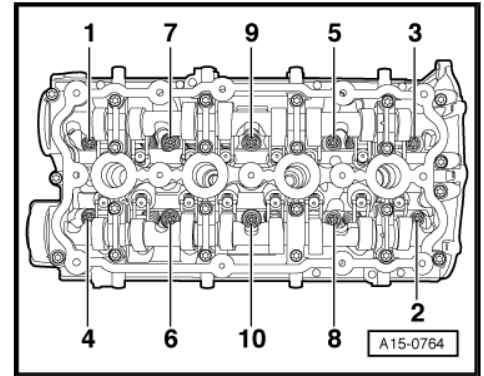
**Tightening sequence for cylinder head**

- Then tighten cylinder head bolts in the sequence -1 ... 10- as follows:
 1. Tighten with torque wrench initially to 40 Nm.
 2. Turn 90° (1/4 turn) further using a rigid wrench.
 3. Turn 90° (1/4 turn) further using a rigid wrench.

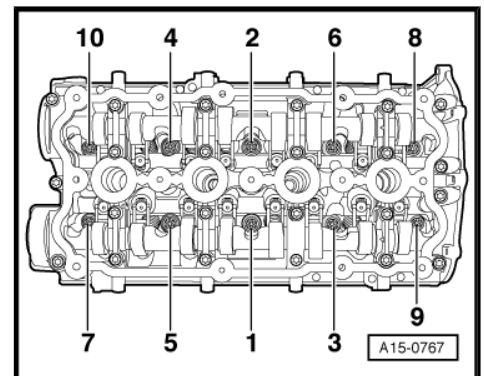
**Checking cylinder head for distortion**

- Use straight edge and feeler gauge to measure for distortion at several points.
- ◆ Max. permissible distortion: 0.05 mm

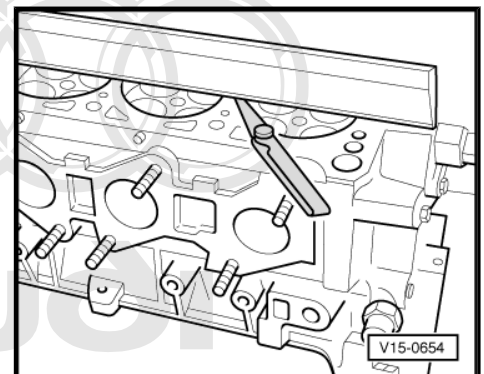



Protected by copyright. Copying for private or commercial purposes, in part or in whole, is not permitted unless authorised by AUDI AG. AUDI AG does not guarantee or accept any liability with respect to the correctness of information in this document. Copyright by AUDI AG.



2.2 Removing and installing inlet camshaft control valve 1 -N205-

Special tools and workshop equipment required

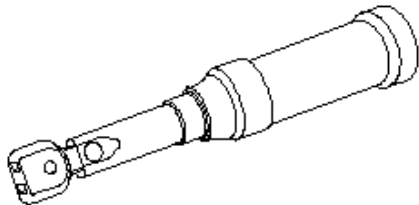
- ◆ Torque wrench -V.A.G 1783-
- ◆ Torx bit set -V.A.G 1766-
- ◆ Ratchet insert 1/4" -VAS 6234-
- ◆ Spring type clip pliers - VAS 5024 A-

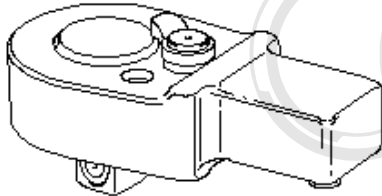
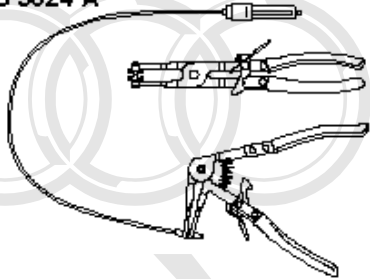
<p>V.A.G 1783</p> 	<p>V.A.G 1766</p> 
<p>VAS 6234</p> 	<p>VAS 5024 A</p> 
<p style="text-align: center;">Protected by copyright. Copying for private or commercial purposes, in part or in whole, is not permitted unless authorised by AUDI AG. AUDI AG does not guarantee or accept any liability with respect to the correctness of information in this document. Copyright by AUDI AG.</p> <div style="text-align: right; border: 1px solid black; padding: 2px;">G15-10015</div>	

Removing



Note

Always renew seals and gaskets.

- Unplug electrical connector at air mass meter -G70- -3-.
- Open clamps -1 and 2- and disconnect air intake hose from air mass meter.
- Detach air intake connection at lock carrier -4-.
- Pull off engine cover panel.

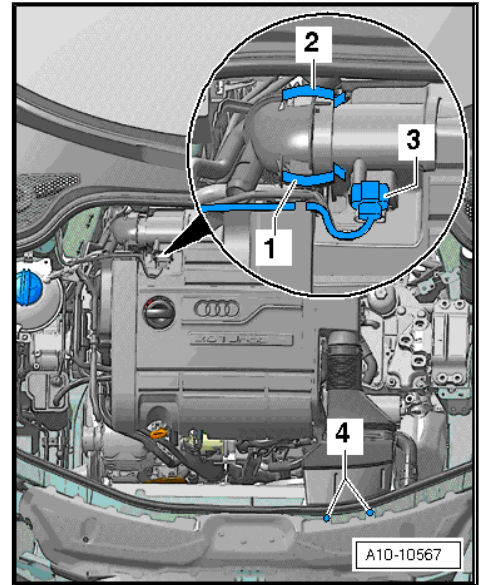

- Unplug electrical connector -1-.
- Detach wiring harness -2- from bracket.
- Remove bolt -3-.

 **Note**

Do not pull on electrical connector when removing inlet camshaft control valve 1 -N205- .

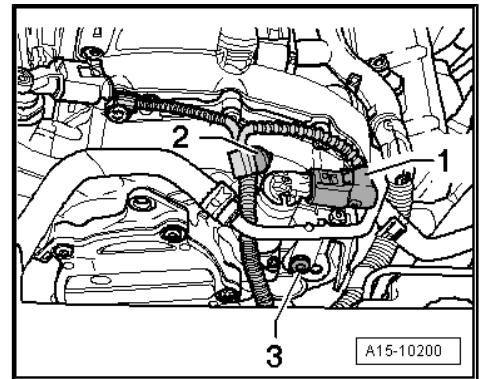



- Remove bolts -arrows- and take inlet camshaft control valve 1 -N205- out of housing.

Installing

- Tightening torque ⇒ [page 77](#)



Note

- ◆ *Make sure the inlet camshaft control valve 1 -N205- and the housing are free from any kind of dirt.*
- ◆ *Do not remove inlet camshaft control valve 1 -N205- from packaging until you are ready to install it.*

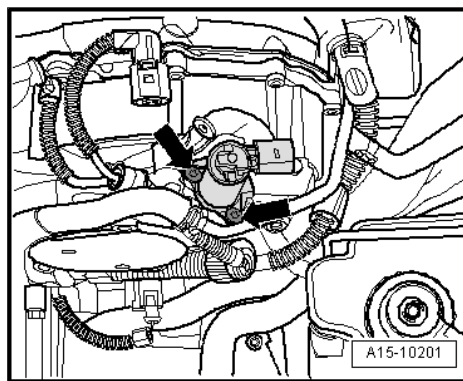

Caution

- ◆ *Do not expose the inlet camshaft control valve 1 -N205- to shock impacts.*

- Lubricate the seal with engine oil.
- Carefully fit inlet camshaft control valve 1 -N205- into housing and press in by hand as far as the stop (exert pressure in line with axis of valve).
- Screw in and tighten bolts using torque wrench -V.A.G 1783- and ratchet insert 1/4" -VAS 6234- and Torx bit T20 and bit holder from Torx bit set -V.A.G 1766- .

Further assembly is basically carried out in reverse order of dismantling.

Protected by copyright. Copying for private or commercial purposes, in part or in whole, is not permitted unless authorised by AUDI AG. AUDI AG does not guarantee or accept any liability for errors or omissions. Copyright by AUDI AG.

2.3 Removing and installing cylinder head cover

Removing

Special tools and workshop equipment required

- ◆ Puller -T40039-

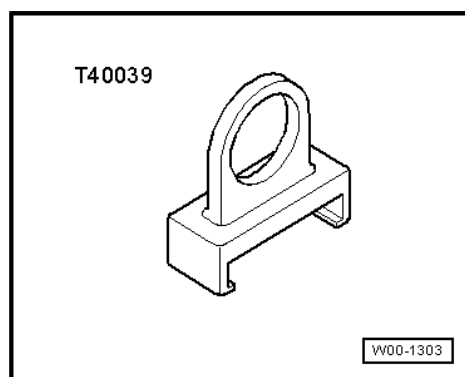

◆ Hose clip pliers -V.A.G 1921-

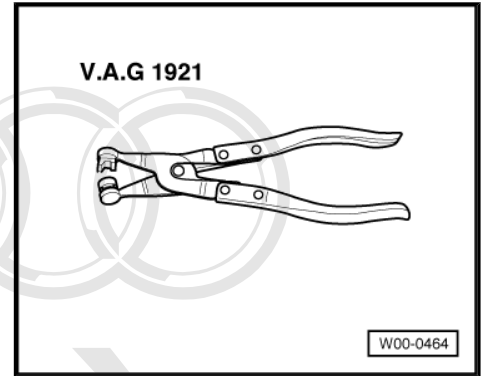

- Unplug electrical connector at air mass meter -G70- -3-.
- Open clamps -1 and 2- and disconnect air intake hose from air mass meter.
- Detach air intake connection at lock carrier -4-.
- Pull off engine cover panel.

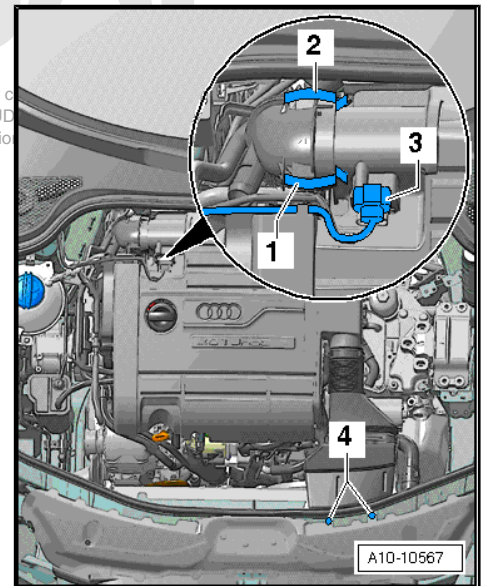

- Remove air intake hose -arrow- using hose clip pliers -V.A.G 1921- .

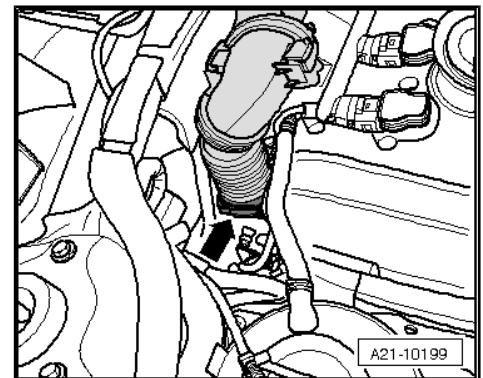

- Unscrew bolts -arrows-.
- Remove ignition coils with output stages => Rep. Gr. 28 .

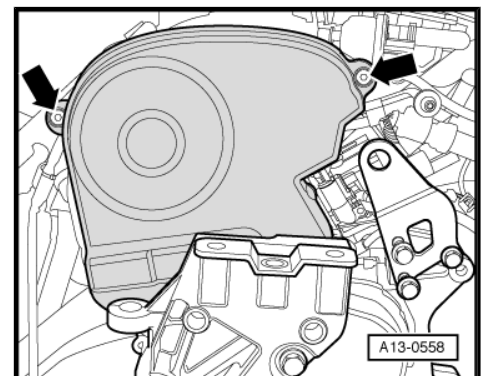



- Disconnect ACF pipe from cylinder head cover -1-.
- Detach valve housing from cylinder head cover -arrows-.

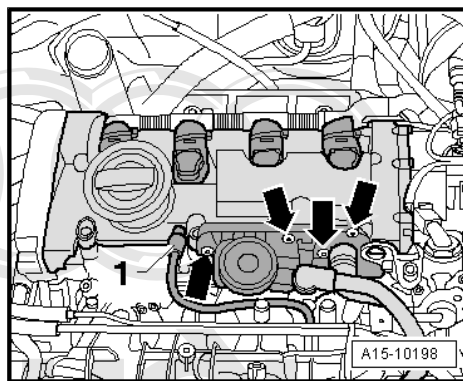

- Unscrew crankcase breather line with heat shield from turbocharger -1-.
- Disconnect ACF line going to turbocharger from cylinder head cover -2-.
- Loosen cylinder head cover working from outside to inside.
- Remove cylinder head cover.

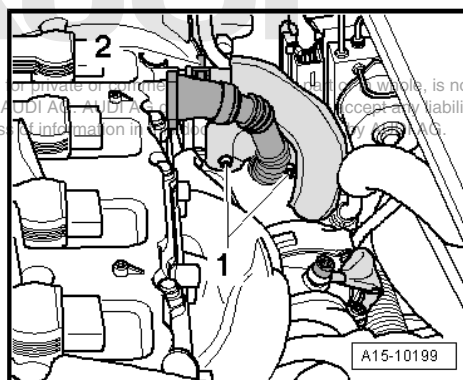

Installing

Installation is carried out in the reverse order; note the following:

- Tightening torque => [page 77](#)



Note

- ◆ *Renew cylinder head cover gaskets if damaged.*
- ◆ *Tightening sequence for cylinder head cover => [page 78](#)*
- Make sure toothed belt cover (top) is correctly fitted.
- Install ignition coils with output stages => Rep. Gr. 28 .

2.4 Removing and installing cylinder head

Special tools and workshop equipment required

- ◆ Drip tray for workshop hoist -VAS 6208-
- ◆ Counterhold tool -3036-
- ◆ Two-arm puller -T40001-
- ◆ Puller -T40039-
- ◆ Hose clip pliers -V.A.G 1921-

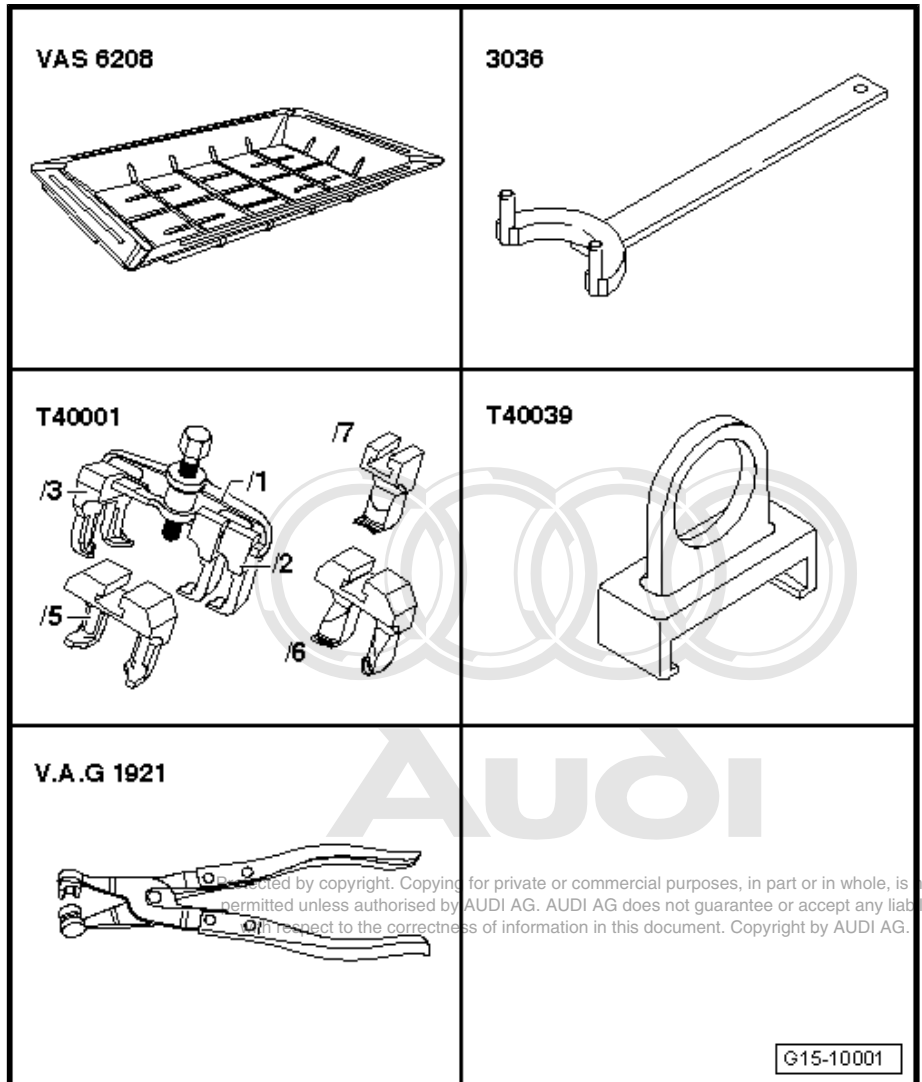

Pin wrench -T10020-

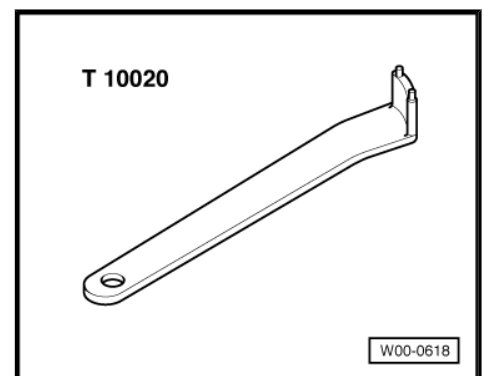



Locking pin -T10060A-

Removing

- Engine in vehicle.



Note

- ◆ All cable ties which are released or cut open when removing must be refitted in the same position when installing.
- ◆ If engine oil is contaminated, perform oil change => Maintenance ; Booklet 810 .
- ◆ Before applying sealant, check updated information: => Parts catalogue

- Obtain code on vehicles with coded radio / radio and navigation system (RNS).
- Unplug electrical connector at air mass meter -G70- -3-.
- Open clamps -1 and 2- and disconnect air intake hose from air mass meter.
- Detach air intake connection at lock carrier -4-.
- Pull off engine cover panel.

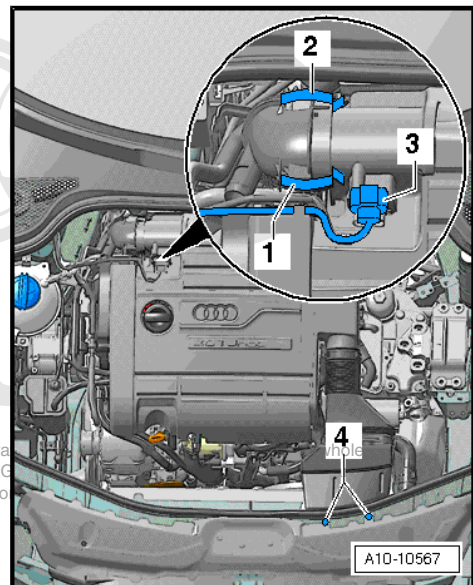
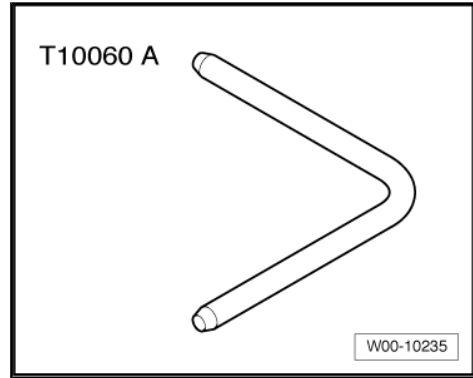

Protected by copyright. Copying for private use is permitted unless authorised by AUDI AG with respect to the correctness of info

- Remove air intake hose -arrow- using hose clip pliers -V.A.G 1921- .

WARNING

Hot steam/hot coolant may escape when opening expansion tank. Cover cap with cloth and open carefully.

- Open filler cap on coolant expansion tank

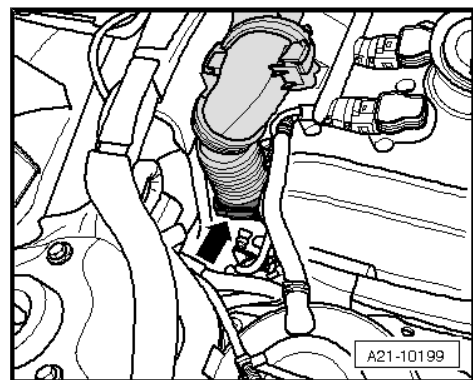

- Remove centre noise insulation -fasteners 1 ... 4-

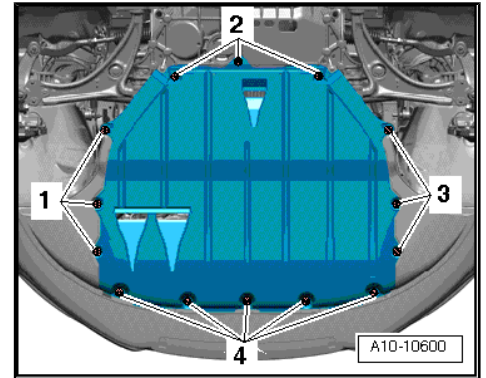

- Remove right noise insulation -arrows-

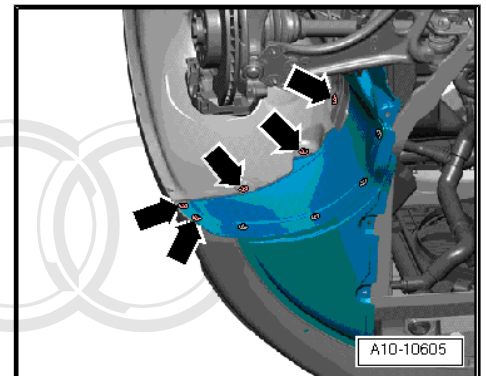

- Remove noise insulation frame -arrow-
- Drain off coolant => [page 147](#)

Protected by copyright. Copying for private or commercial use is not permitted unless authorised by AUDI AG. AUDI AG is not liable with respect to the correctness of information in this manual.

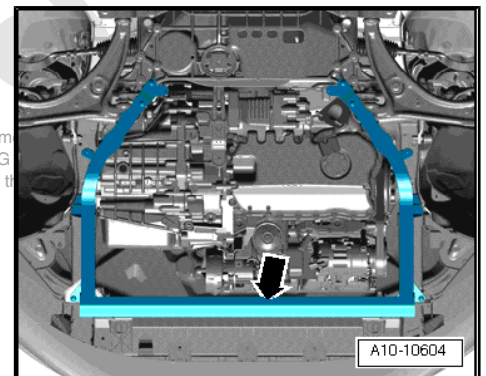

- Remove electrical connector -arrow- for Lambda probe (before catalytic converter) from bracket, unplug and move clear.

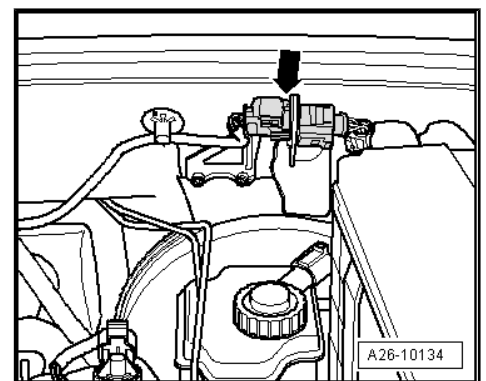



- Disconnect coolant pipe going to coolant expansion tank -arrow-.

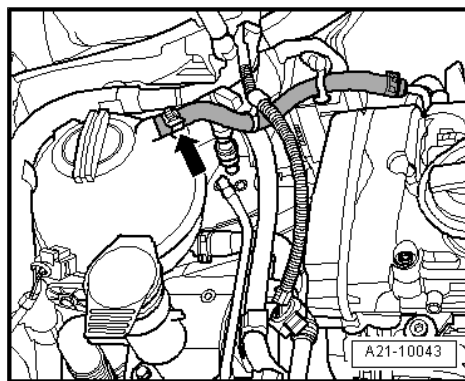

- Disconnect coolant hose -1-.
- Disconnect coolant hose -2-.

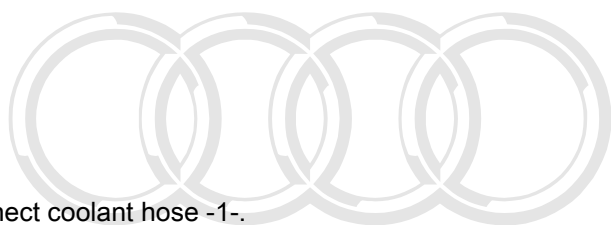

Protected by copyright. Copying for private or commercial purposes, in part or in whole, is not permitted unless authorised by AUDI AG. AUDI AG does not guarantee or accept any liability with respect to the correctness of information in this document. Copyright by AUDI AG.

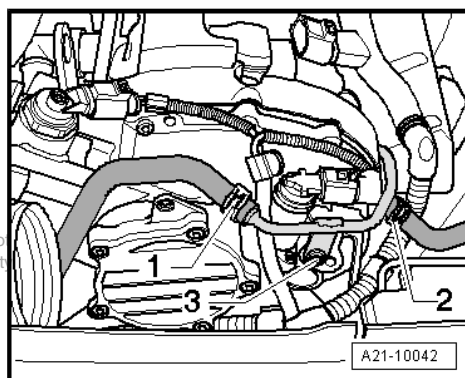

- Disconnect earth cable -1-.
- Unplug electrical connector -2-.
- Disconnect water hoses -arrows-.
- Remove intake manifold => Motronic direct injection and ignition system (4-cylinder); Repair group 24; Servicing injection system

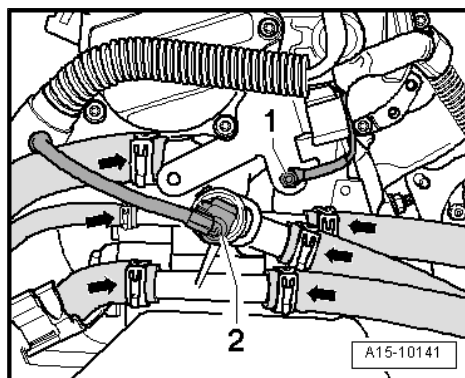

- Unbolt heat shield for drive shaft (right-side) -arrows-.

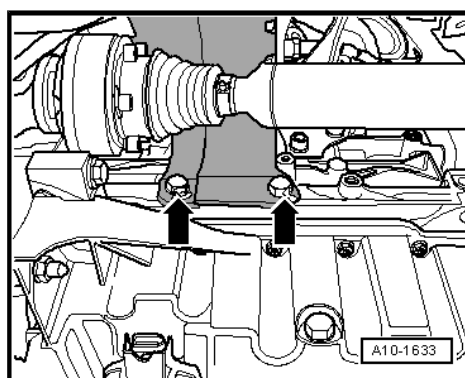

- Remove nuts -1- and -2- on bracket for electrical connector for Lambda probe on underside of vehicle and remove cover.
- Unscrew bolt -3- and move electrical wire for Lambda probe clear.

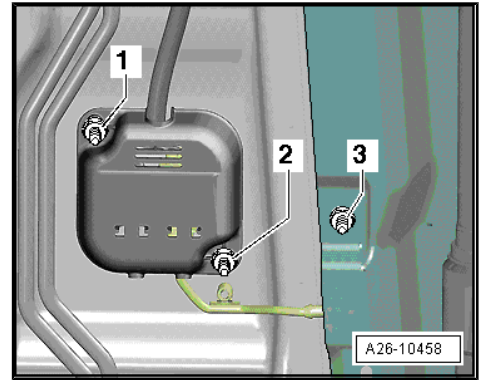

- Detach plug connector from bracket -arrow-.
- Unplug connector for Lambda probe after catalytic converter -G130- .

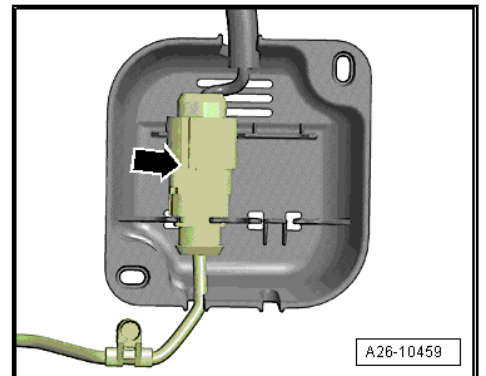

- Unscrew remaining securing nuts -arrows- for front exhaust pipe/turbocharger from below.

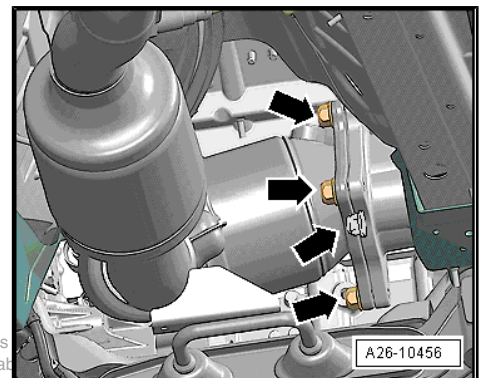

Protected by copyright. Copying for private or commercial purposes, in part or in whole, is permitted unless authorised by AUDI AG. AUDI AG does not guarantee or accept any liability with respect to the correctness of information in this document. Copyright by AUDI AG.

- Unbolt bracket for exhaust system and tunnel brace -arrows-.

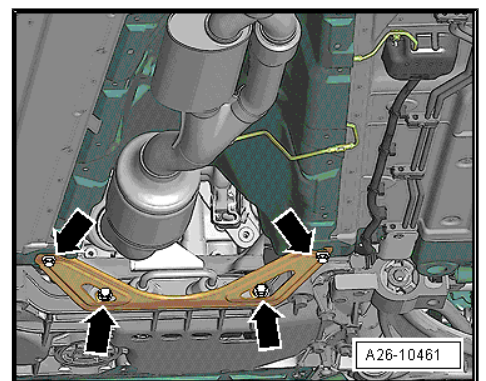

**Note**

To avoid any damage, the flexible joint in the front exhaust pipe must not be bent more than 10°.

- Separate exhaust system at clamp -arrows-.
- Remove front exhaust pipe with catalytic converter and front silencer.
- Remove drive shaft (right-side) ⇒ Rep. Gr. 40
- Detach air pipe -arrow- from charge air cooler.

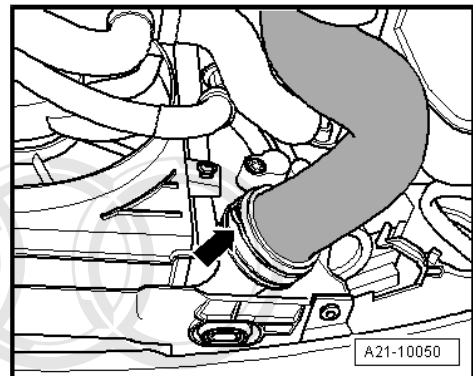
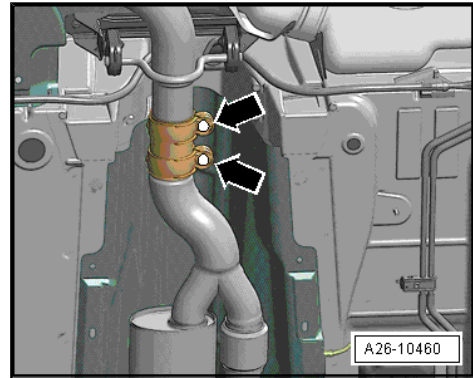

- Unbolt air pipe from turbocharger -arrows-.
- Detach electrical connectors -1 and 2- and move wire clear.

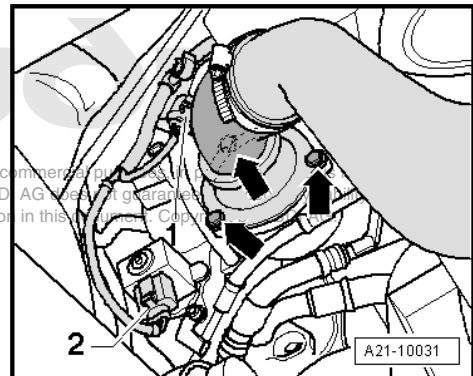

- Unscrew bolts -arrows- and remove air pipe.

**Note**

Shown in illustration from rear with engine removed.

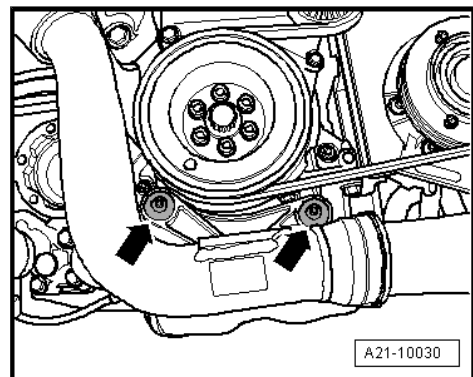

Protected by copyright. Copying for private or commercial use is not permitted unless authorised by AUDI AG. AUDI AG does not guarantee with respect to the correctness of information in this manual. Copyright

- Unscrew oil supply pipe for turbocharger at cylinder block -1-
- Remove oil supply pipe for turbocharger -2-.

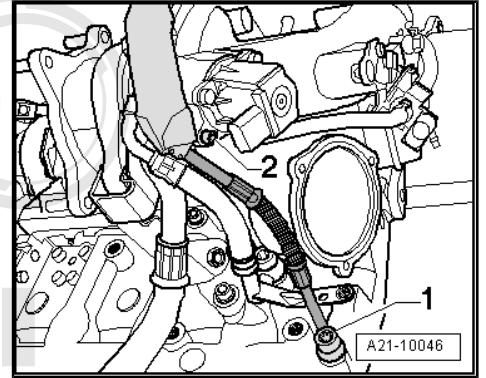

- Unscrew coolant supply pipe for turbocharger at cylinder block -1-
- Unscrew coolant supply pipe at turbocharger -2-.
- Detach coolant supply pipe for turbocharger -3- from cylinder block.

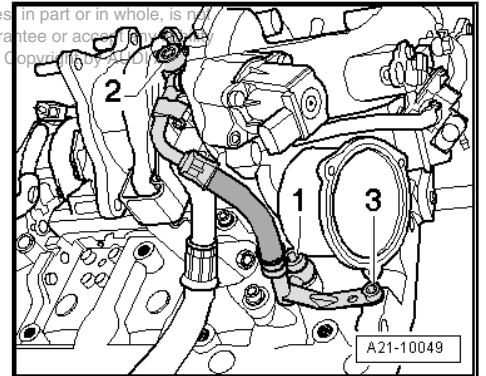

- Remove oil return pipe -arrows- at turbocharger.

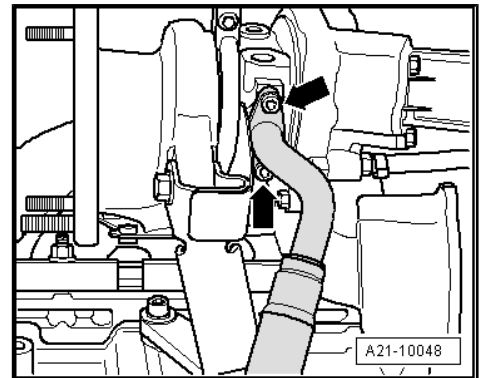

- Remove bolts -1- and -2- and remove support for turbocharger.
- Remove toothed belt => [page 66](#) .

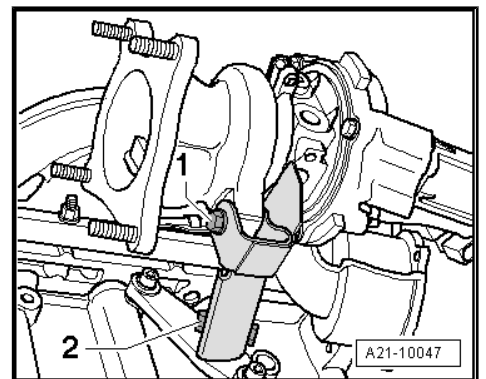



- Loosen the camshaft sprocket bolt using counterhold -3036- .

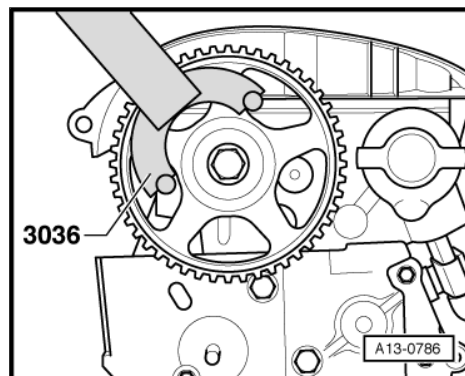

- Detach camshaft sprocket using two-arm puller -T40001- with claws -T40001/6- and -T40001/7- .

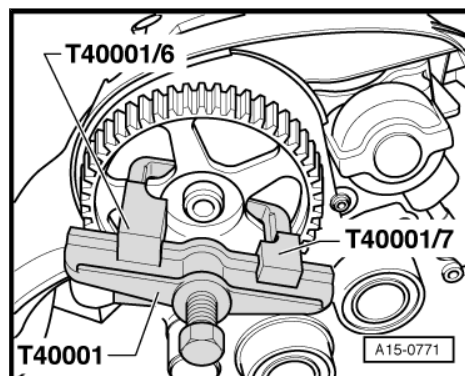

- Unbolt toothed belt cover (rear) from cylinder head -arrows-.
- Remove cylinder head cover => [page 82](#) .

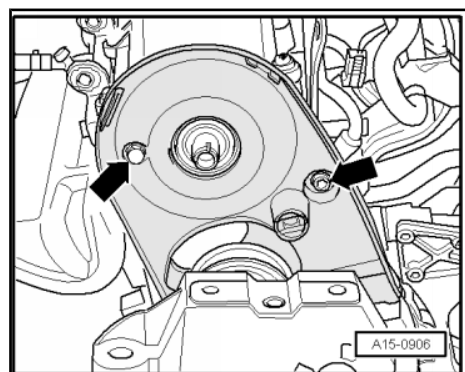

Audi

Protected by copyright. Copying for private or commercial purposes, in part or in whole, is not permitted unless authorised by AUDI AG. AUDI AG does not guarantee or accept any liability with respect to the correctness of information in this document. Copyright by AUDI AG.

- Loosen cylinder head bolts, keeping to sequence shown.

 **Note**

Check that all hoses, pipes and wiring connections between engine, gearbox and body have been detached.

- Remove cylinder head.

Installing cylinder head

- Tightening torques and tightening sequence ⇒ [page 77](#)
- Tightening torques ⇒ [page 190](#)

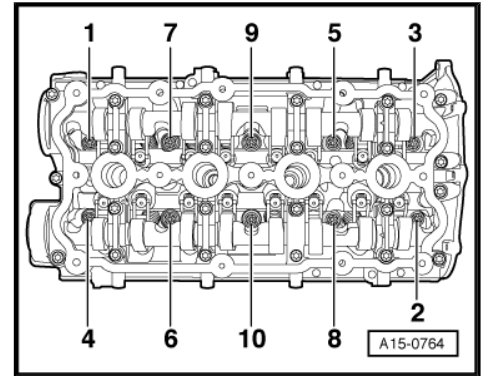

 **Note**

- ◆ *Renew the cylinder head bolts.*
- ◆ *On assembly, renew oil seals and gaskets as well as self-locking nuts and bolts that are tightened by turning through to a specified angle.*
- ◆ *Secure all hose connections with the correct type of hose clips (same as original equipment) ⇒ Parts catalogue.*
- ◆ *If repairing, carefully remove any remaining gasket material from the cylinder head and cylinder block. Ensure that no long scores or scratches are made on the surfaces.*
- ◆ *Carefully remove any remaining emery and abrasive material.*
- ◆ *Do not remove new cylinder head gasket from packaging until it is ready to be fitted.*
- ◆ *Handle gasket very carefully. Damage to the silicone coating or the indented area will lead to leaks.*
- ◆ *No oil or coolant must be allowed to remain in the blind holes for the cylinder head bolts in the cylinder block.*
- ◆ *High-temperature paste ⇒ Parts catalogue*



WARNING

Protected by copyright. Copying for private or commercial purposes, in part or in whole, is not permitted unless authorised by AUDI AG. AUDI AG does not guarantee or accept any liability with respect to the correctness of information in the document. Copyright by AUDI AG.

The engine must only be turned at the crankshaft, in the direction of normal engine rotation (clockwise).

 **Note**

Apply spanner to central bolt of crankshaft for turning engine.



- Align mark on camshaft sprocket with mark on toothed belt cover. The indentations on the camshafts -arrows- face each other.
- If crankshaft has been rotated: set No. 1 cylinder piston to top dead centre and then turn crankshaft back slightly.

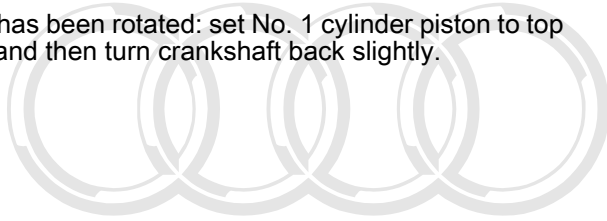

Audi

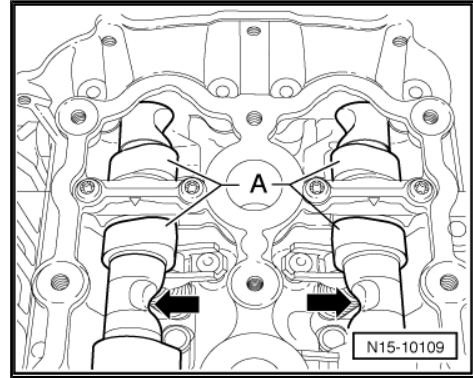

Protected by copyright. Copying for private or commercial purposes, in part or in whole, is not permitted unless authorised by AUDI AG. AUDI AG does not guarantee or accept any liability with respect to the correctness of information in this document. Copyright by AUDI AG.

- Place cylinder head gasket in position.
- ◆ Note position of centralising pins in cylinder block -arrows-.
- ◆ Note installation position of cylinder head gasket. The Part No. should be legible from inlet side.
- Fit cylinder head.
- Insert and hand-tighten cylinder head bolts.
- Tightening sequence for cylinder head ⇒ [page 79](#) :

 **Note**

Cylinder head bolts do not have to be torqued down again later after repair work.

- Install cylinder head cover ⇒ [page 85](#) .
- Install wiper arms ⇒ Electrical system; Repair group 92 .
- Install toothed belt ⇒ [page 66](#) .
- Install poly V-belt ⇒ [page 33](#) .
- Electrical connections and routing ⇒ Current flow diagrams, Electrical fault finding and Fitting locations
- Install intake manifold ⇒ Motronic direct injection and ignition system (4-cylinder); Repair group 24; Servicing injection system
- Installing air pipes with connectors ⇒ [page 164](#)
- Connect battery ⇒ Electrical system; Repair group 27
- Bleed fuel system ⇒ Motronic direct injection and ignition system (4-cylinder); Repair group 24; Servicing fuel injection system
- Check oil level ⇒ Maintenance ; Booklet 810 .
- Fill up with coolant ⇒ [page 147](#) .

 **Note**

- ◆ *Drained-off coolant may only be used again if the original cylinder head and cylinder block are re-installed.*
- ◆ *Contaminated or dirty coolant must not be used again.*



WARNING

Never use battery charging equipment for boost starting. There is danger of damaging the vehicle's control units.

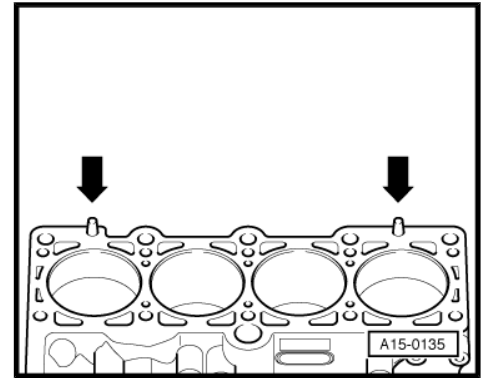

2.5 Checking compression

Special tools and workshop equipment required



- ◆ Spark plug socket and extension -3122 B-

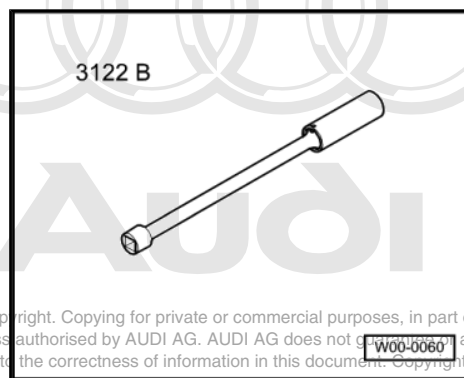

- ◆ Puller -T40039-

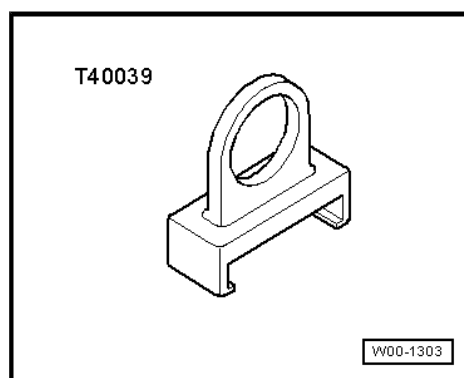

- ◆ Compression tester -V.A.G 1763-

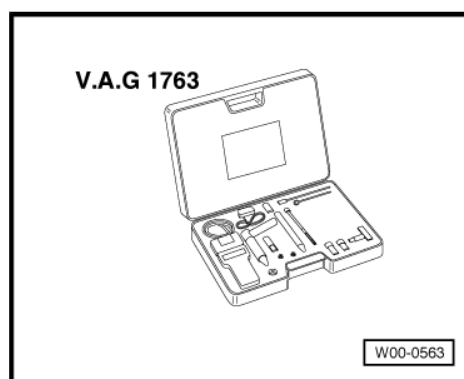

Special tools and workshop equipment required

- ◆
Test sequence

 **Note**

- ◆ *Engine oil temperature at least 30 °C*
- ◆ *Battery voltage at least 12.7 V*

- Unplug electrical connector at air mass meter -G70- -3-.
- Open clamps -1 and 2- and disconnect air intake hose from air mass meter.
- Detach air intake connection at lock carrier -4-.
- Pull off engine cover panel.
- Remove ignition coils with output stages ⇒ Rep. Gr. 28 .
- Remove spark plugs with spark plug socket -3122 B- .
- Unplug 8-pin connector for injectors ⇒ Rep. Gr. 24
- Check compression pressure with compression tester -V.A.G 1763- and adapter -V.A.G 1763/6- .

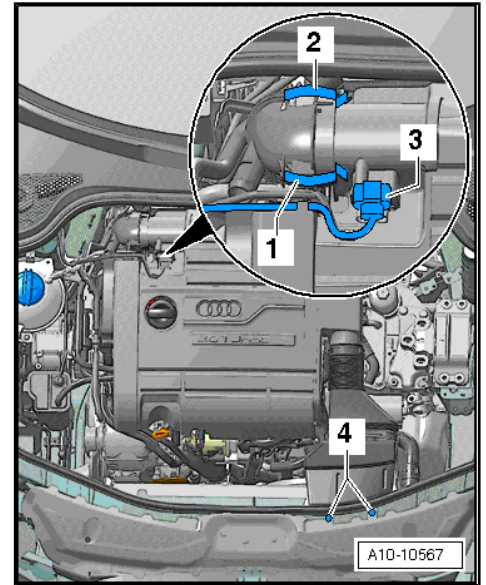

 **Note**

Using the compression tester: ⇒ *Operating Instructions*

- Operate starter until pressure reading on tester no longer rises.

Compression pressure:

New pressure in bar	Wear limit in bar	Permissible difference between cylinders in bar
11.0 ... 14.0	7.0	3.0 (maximum)

- Install spark plugs ⇒ Maintenance ; Booklet 810 .
- Install ignition coils with output stages ⇒ Rep. Gr. 28 .

 **Note**

Faults will have been stored in the memory because connectors have been unplugged. Interrogate and, if necessary, erase fault memory after completing the check.

- Read out fault memory of engine control unit. ⇒ VAS 5051 vehicle diagnostic, testing and information system in the function "Guided fault-finding"



3 Valve gear



Note

- ◆ *Cylinder head and retaining frame must be renewed together.*
- ◆ *After installing camshafts, wait for approx. 30 minutes before starting engine. Hydraulic valve compensation elements have to settle (otherwise valves will strike pistons).*
- ◆ *After working on the valve gear, turn the engine carefully at least 2 rotations to ensure that none of the valves make contact when the starter is operated.*
- ◆ *Always fit new seals and gaskets.*

3.1 Valve gear - exploded view

1 - Bolt

- 50 Nm + turn 180° further
- Renew
- Use counterhold tool -3036- when loosening and tightening
⇒ [page 64](#)

2 - Camshaft sprocket

3 - Oil seal

- Renewing ⇒ [page 114](#)

4 - Cylinder head

- Machining limit
⇒ [page 100](#)

5 - Valve guide

- Checking ⇒ [page 112](#)

6 - Valve stem oil seal

7 - Valve spring

8 - Upper valve spring plate

9 - Cotters

10 - Hydraulic valve clearance compensation element

- Do not interchange
- Lubricate contact surface

11 - Parallel key

- Check for firm attachment

12 - Exhaust camshaft

- Checking axial clearance ⇒ [page 107](#)
- Check radial clearance with Plastigage (roller rocker fingers removed)
- Radial clearance when bearing \varnothing is 24 mm: 0.024 ... 0.066 mm
- Radial clearance when bearing \varnothing is 32 mm: 0.030 ... 0.051 mm

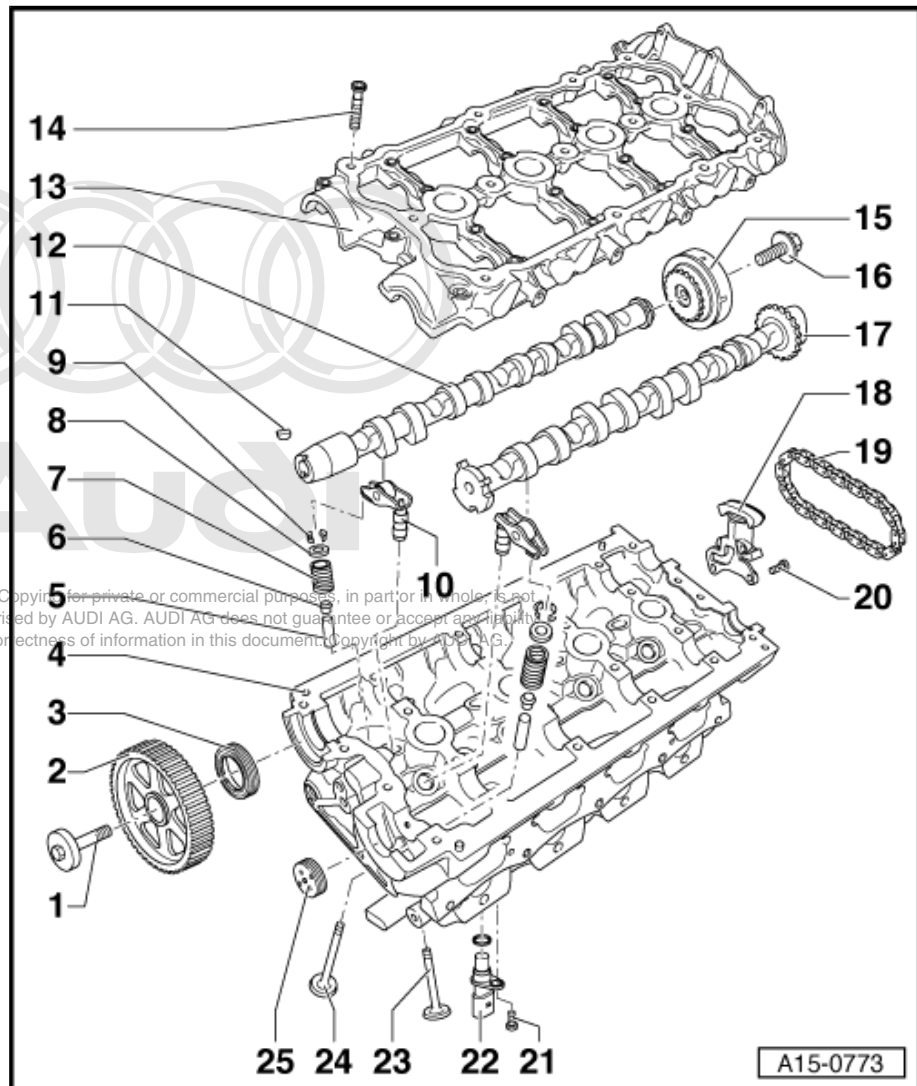

- Runout: max. 0.04 mm

13 - Retaining frame

- With integrated camshaft bearings
- Clean sealing surface; machining not permitted
- Remove old sealant residues

14 - Bolt

- Renew
- Tightening sequence ⇒ [page 100](#)

15 - Camshaft adjuster

16 - Bolt

- 20 Nm + turn 45° further
- Renew

17 - Inlet camshaft

- Checking axial clearance ⇒ [page 107](#)
- Check radial clearance with Plastigage (roller rocker fingers removed)
- Radial clearance when bearing \varnothing is 24 mm: 0.024 ... 0.066 mm
- Runout: max. 0.04 mm

18 - Chain tensioner

- Remove ⇒ [page 101](#) Removing and installing camshaft adjuster
- Before removing, lock in place using locking pin -T10115-

19 - Drive chain

20 - Bolt

- 10 Nm

21 - Bolt

- 10 Nm

22 - Phase sensor

Protected by copyright. Copying for private or commercial purposes, in part or in whole, is not permitted unless authorised by AUDI AG. AUDI AG does not guarantee or accept any liability with respect to the correctness of information in this document. Copyright by AUDI AG.

23 - Exhaust valve

- Do not machine, only grinding-in is permitted
- Valve dimensions ⇒ [page 100](#)
- Checking valve guides ⇒ [page 112](#)

24 - Inlet valve

- Do not machine, only grinding-in is permitted
- Valve dimensions ⇒ [page 100](#)
- Checking valve guides ⇒ [page 112](#)

25 - Sealing cap

- Renew
- Removing sealing cap with retaining frame installed: pierce on one side with an awl and pry out
- Installing: press in 1 ... 2 mm deep without sealant using thrust piece -3334-



Cylinder head machining limit

- Machining of the cylinder head (surface grinding) is only permissible down to the minimum dimension a.
- ◆ Minimum dimension a = 139.20 mm

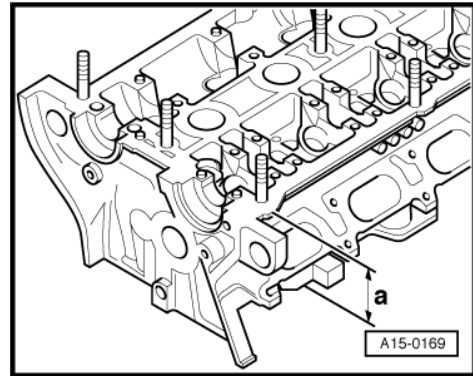

Tightening sequence for retaining frame

- Proceed as follows:
 1. Fit bolts in the sequence -1 ... 6- and hand-tighten in several stages.
 2. Tighten bolts in the sequence -1 ... 6- to 8 Nm using torque wrench.
 3. Turn 90° (1/4 turn) further in the sequence -1 ... 6- using a rigid wrench.

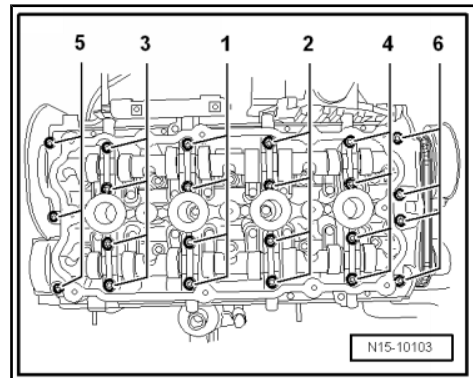

Note

Take care to keep retaining frame straight.

Valve dimensions



Note

Inlet and exhaust valves must not be machined. Only grinding-in is permitted.

Dimension		Inlet valve	Exhaust valve
∅ a	mm	33.85 ± 0.10	28.0 ± 0.1
∅ b	mm	5.98 ± 0.01	5.96 ± 0.01
c	mm	104.0 ± 0.2	101.9 ± 0.2
α	∠°	45	45

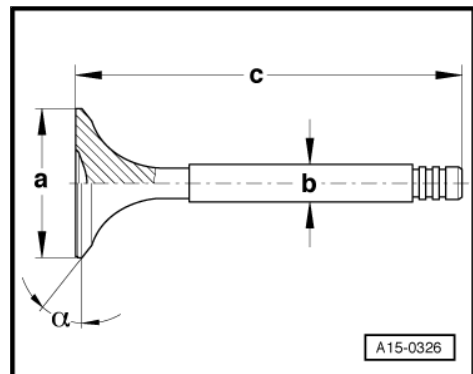

Audi

Protected by copyright. Copying for private or commercial purposes, in part or in whole, is not permitted unless authorised by AUDI AG. AUDI AG does not guarantee or accept any liability with respect to the correctness of information in this document. Copyright by AUDI AG.

3.2 Removing and installing camshaft adjuster

Special tools and workshop equipment required

- ◆ Special wrench, long reach -T40080-
- ◆ Camshaft clamp -T10252-
- ◆ Pin wrench -T10020-
- ◆ Locking pin -T10115-

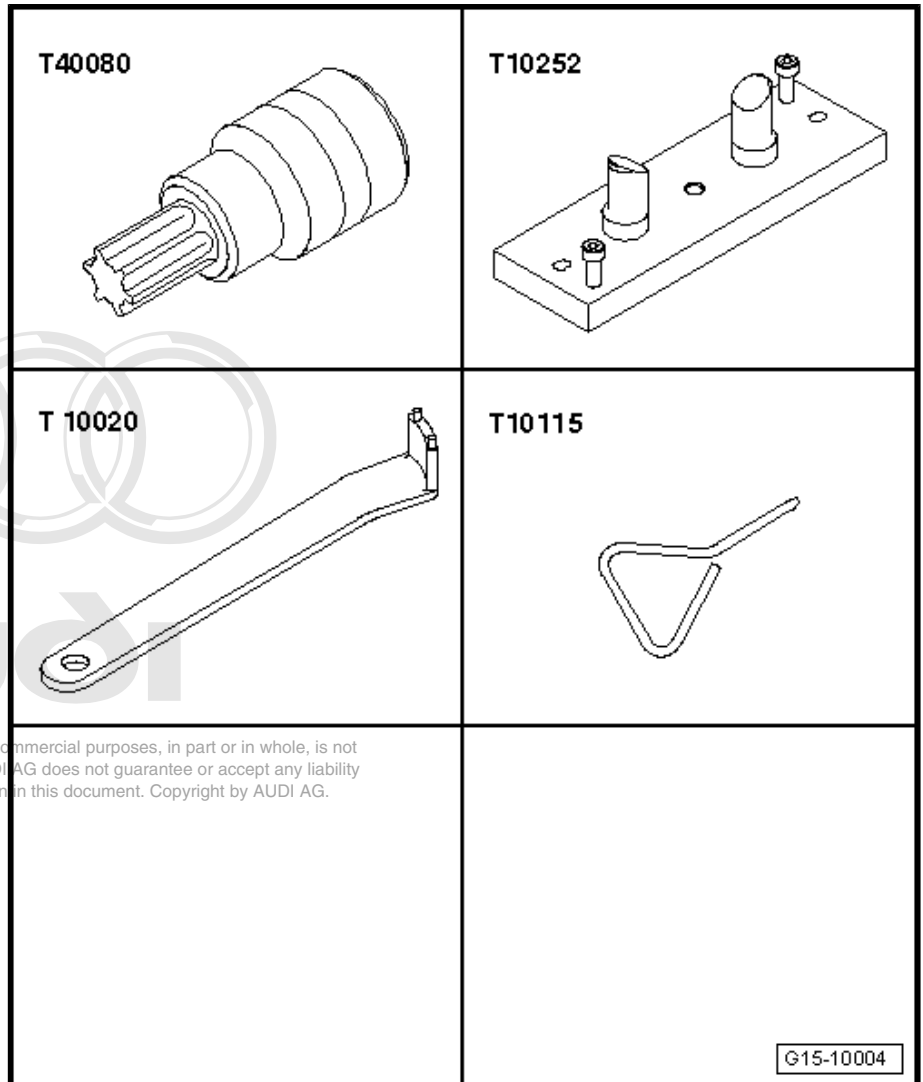

Removing

- Remove high-pressure pump ⇒ Rep. Gr. 24 .
- Remove cylinder head cover ⇒ [page 82](#) .
- Remove exhauster pump.
- Remove housing for camshaft adjuster -arrows-.

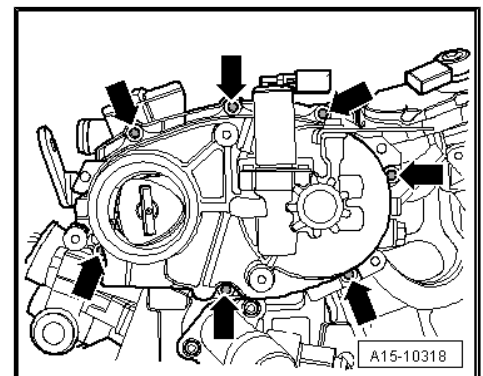



- Align mark on camshaft sprocket with mark on toothed belt cover. The indentations on the camshafts -arrows- face each other.

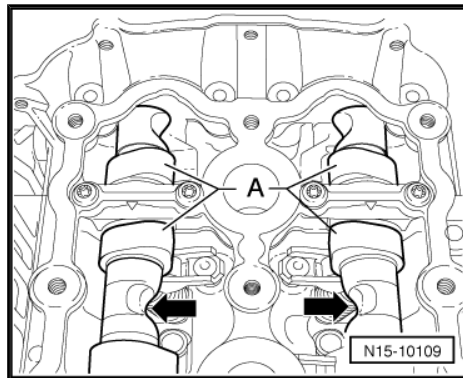

- Fit camshaft clamp -T10252- as shown and secure -arrows-.
- Loosen securing bolt from camshaft adjuster using special wrench -T40080- .

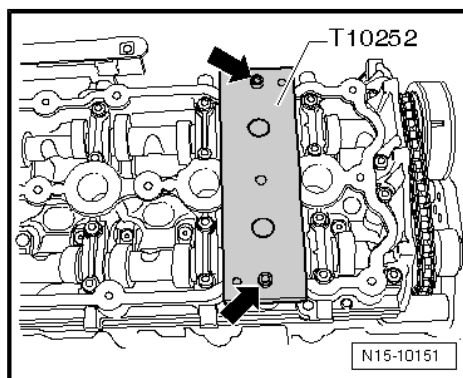

- Compress chain tensioner -arrow A- and lock with locking pin -T10115- -arrow B-.
- Remove securing bolt from camshaft adjuster and remove camshaft adjuster together with chain.

Installing

- Tightening torques => [page 98](#)
- Tightening torques => [page 77](#)

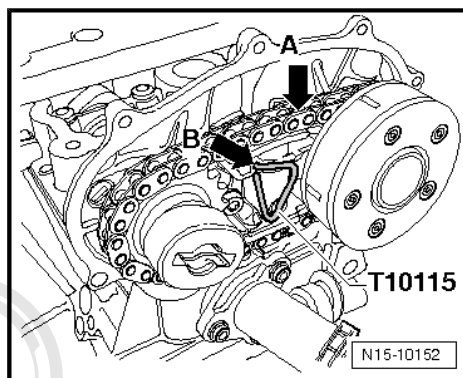

- The camshafts are located with the camshaft clamp -T10252- .
- Fit chain onto camshaft adjuster.

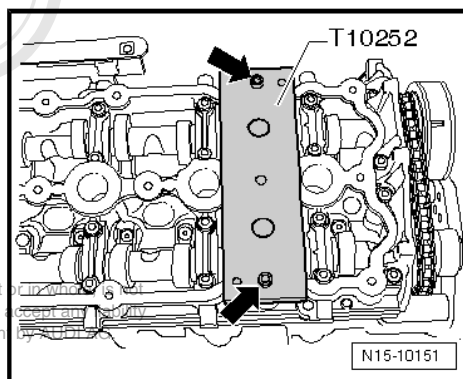

Protected by copyright. Copying for private or commercial purposes, in part or in full, is not permitted unless authorised by AUDI AG. AUDI AG does not guarantee or accept any liability with respect to the correctness of information in this document. Copyright

- Position camshaft adjuster in front of exhaust camshaft so that notch -A- and pin -B- face each other.

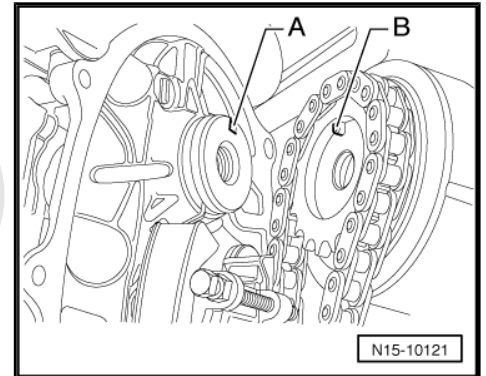

- Lay chain over inlet camshaft sprocket starting at top -arrow- without changing its position.

Protected by copyright. Copying for private or commercial purposes, in part or in whole, is not permitted unless authorised by AUDI AG. AUDI AG does not guarantee or accept any liability with respect to the correctness of information in this document. Copyright by AUDI AG.

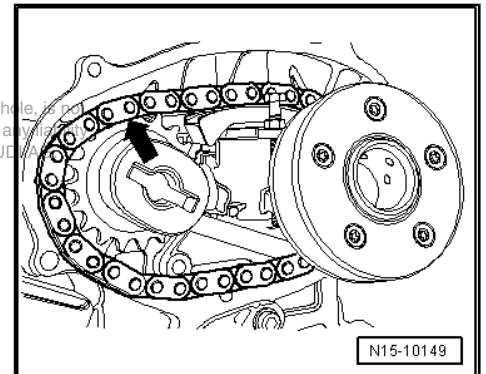

- Turn inlet camshaft slowly in direction of arrow -A- using pin wrench -T10020- until the camshaft adjuster fits onto the camshaft.

Note

If it is not possible to fit the pin into the notch: remove chain and fit chain again.

- Renew securing bolt for camshaft adjuster.
- Tighten securing bolt for camshaft adjuster. Use special wrench -T40080- for this purpose.
- Remove locking pin -T10115- -arrow B-.

Further assembly is basically carried out in reverse order of dismantling.

- Install cylinder head cover ⇒ [page 82](#)
- Install high-pressure pump ⇒ Rep. Gr. 24 .
- Install exhauster pump ⇒ Rep. Gr. 47 .

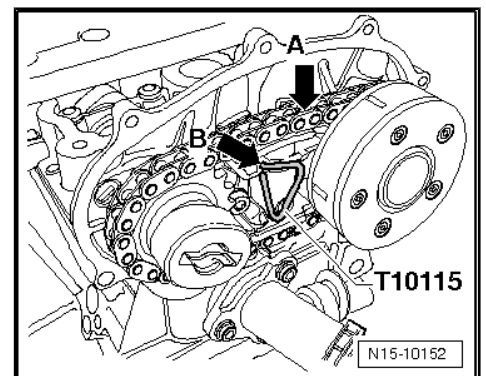
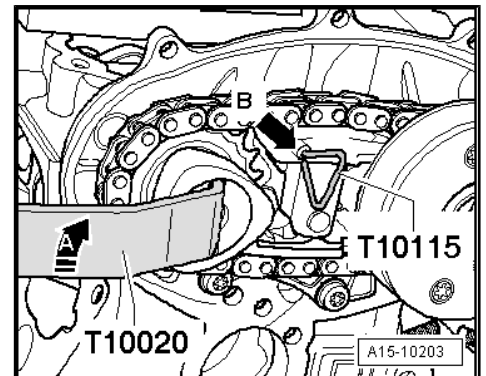

3.3 Removing and installing camshafts

Special tools and workshop equipment required



- ◆ Two-arm puller -T40001-

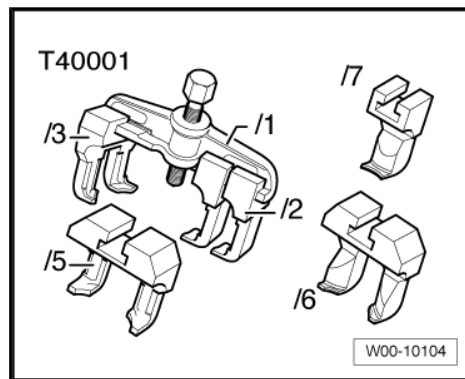

- ◆ Counterhold tool -3036-

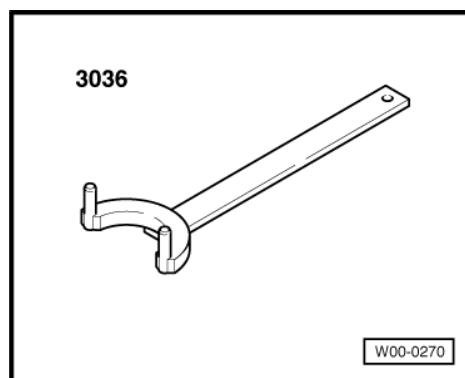

Removing



Note

- ◆ *Sealing surfaces at bottom of retaining frame and top of cylinder head may not be machined.*
- ◆ *The camshaft bearings are integrated into the cylinder head and retaining frame. Toothed belt must be slackened before removing retaining frame.*
- ◆ *Renew camshaft oil seal and sealing cap if retaining frame has been unfastened.*

- Remove cylinder head cover ⇒ [page 82](#)
- Remove camshaft adjuster ⇒ [page 101](#)
- Remove toothed belt ⇒ [page 66](#)
- Loosen camshaft sprocket using counterhold tool -3036-

Protected by copyright. Copying for private or commercial purposes, in part or in whole, is not permitted unless authorised by AUDI AG. AUDI AG does not guarantee or accept any liability with respect to the correctness of information in this document. Copyright by AUDI AG.

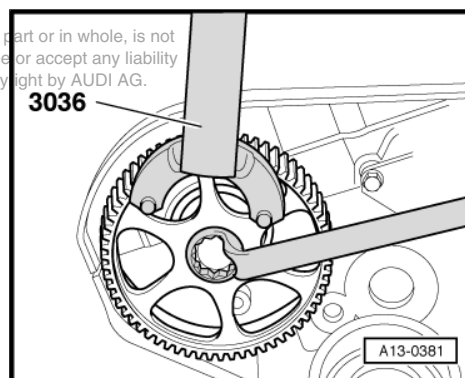

- Use puller -T40001- , claw -T40001/6- and claw -T40001/7- to pull off camshaft sprocket.
- Detach toothed belt cover (rear) from cylinder head.

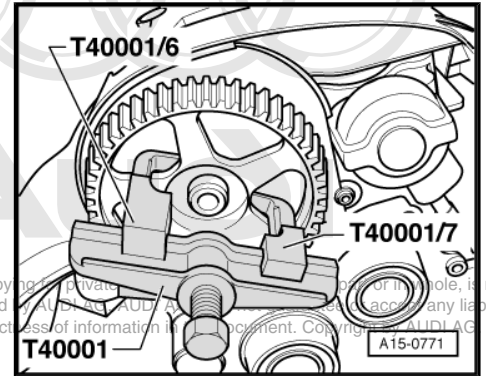

Protected by copyright. Copying or reproducing, or in any way, is not permitted unless authorised by Audi AG. Audi AG assumes no liability with respect to the correctness of information in this document. Copyright © Audi AG

- Unscrew retaining frame bolts in the sequence -6 ... 1- and carefully remove retaining frame.
- Remove camshafts together with drive chain from cylinder head.

Installing

- Tightening torques ⇒ [page 98](#)
- Tightening torques ⇒ [page 77](#)

Note

- ◆ *The sealing surfaces must be free of oil and grease.*
- ◆ *Pistons must not be at TDC.*
- ◆ *Ensure that all roller rocker fingers contact the valve ends correctly.*
- Remove old sealant from groove in retaining frame and from sealing surfaces.
- Make sure dirt and remnants of sealant do not drop into cylinder head.
- Lubricate running surfaces of the camshafts with oil.

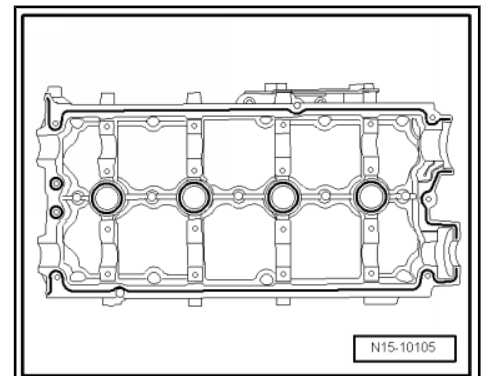
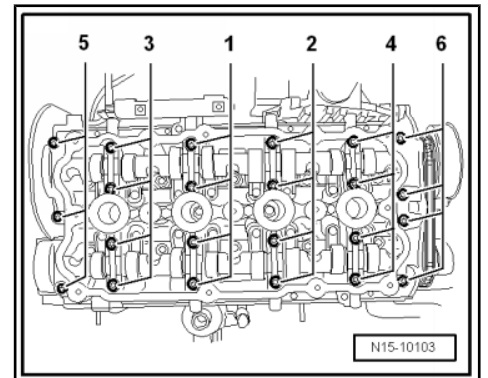

- Position drive chain on chain sprockets as follows (with camshafts removed):
- Lubricate running surfaces of camshafts.
- Cams -A- of cylinder 4 must face each other.
- Recesses -arrows- on both camshafts must face each other.
- The side surfaces of the recesses should be positioned exactly vertical.
- Insert camshafts together with drive chain into cylinder head and chain tensioner.

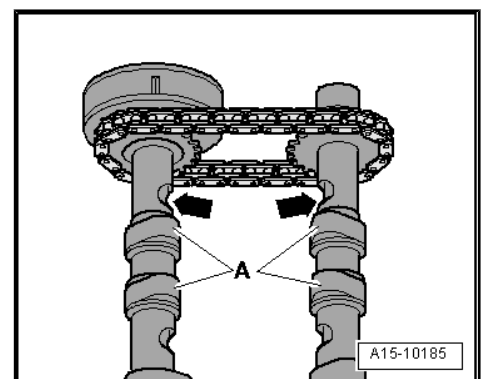



- Check TDC position of camshafts again.
- Cams -A- of cylinder 4 must face each other.
- Recesses -arrows- on both camshafts must face each other.
- The side surfaces of the recesses should be positioned in exactly vertical line to the cylinder head.
- Lubricate running surfaces of camshafts.

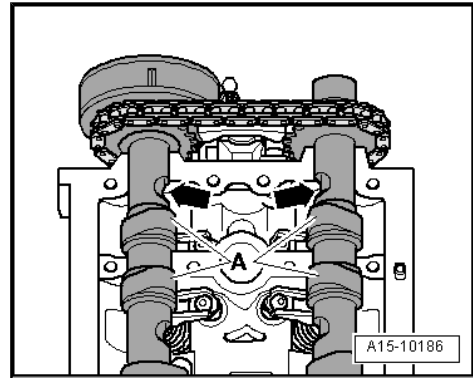

- Apply an even, slightly projecting sealant bead into the clean groove of the retaining frame.

Sealant → Parts catalogue



Note

- ◆ Do not apply the sealant thicker than prescribed.
- ◆ No time should be allowed to elapse when fitting and securing retaining frame, as sealant starts to harden as soon as sealing surfaces make contact.
- ◆ Note the use-by date of the sealant.

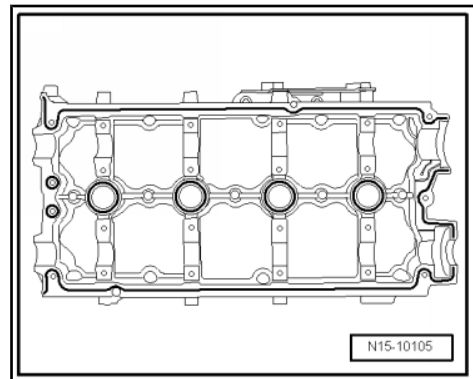

- Fit retaining frame so that it goes past the exhaust gas recirculation valve -N18- -arrow-.
- Renew bolts for retaining frame.



Note

Camshafts must be in correct position in axial bearings in retaining frame.

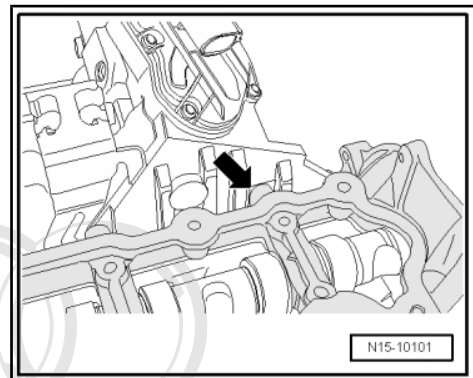

- Tighten bolts in several stages; tightening sequence → [page 100](#) .



Note

Take care to keep retaining frame straight.

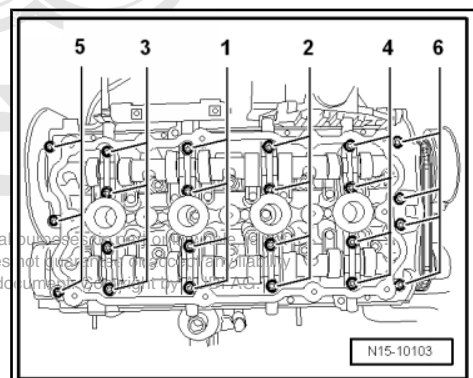

Protected by copyright. Copying for private or commercial purposes is not permitted unless authorised by AUDI AG. AUDI AG does not assume any liability with respect to the correctness of information in this document.

- Then check that camshafts are in TDC position (insert camshaft clamp -T10252- as far as stop).

 **Note**

- ◆ *If necessary, turn camshafts slightly backwards or forwards when inserting camshaft clamp -T10252- .*
- ◆ *Disregard -arrows-.*
- If it is not possible to insert camshaft clamp -T10252- , retaining frame must be removed and camshafts installed for a second time ⇒ [page 105](#) .
- Detach camshaft clamp -T10252- .
- Drive in cap ⇒ [Item 25 \(page 99\)](#) approx. 1...2 mm deep using thrust piece -3334- .
- Install camshaft oil seal ⇒ [page 114](#)
- Install toothed belt cover (rear).
- Insert parallel key into camshaft.
- Install camshaft sprocket. To tighten bolt, hold camshaft sprocket in position using counterhold tool -3036- .

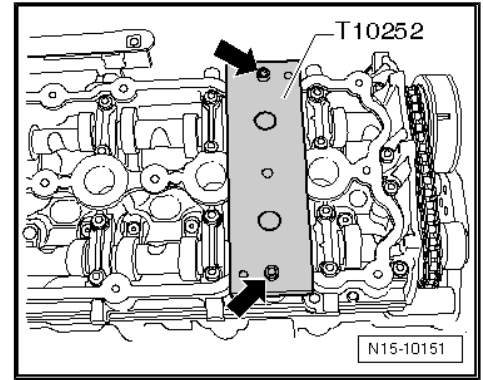

 **Note**

- ◆ *When turning the camshaft, the pistons must not be at TDC. This could otherwise result in damage to valves and pistons.*
- ◆ *Make sure parallel key is correctly seated.*
- Install toothed belt ⇒ [page 66](#) .
- Install camshaft adjuster ⇒ [page 101](#) .
- Install cylinder head cover ⇒ [page 82](#)

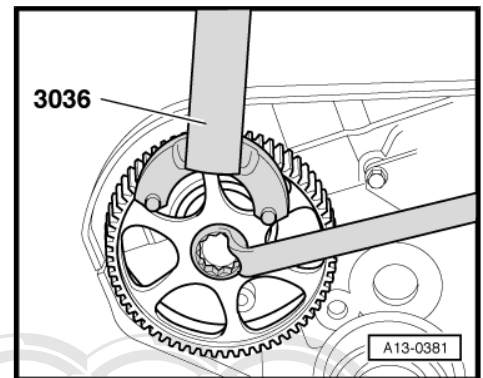

Further assembly is basically carried out in reverse order of dismantling.

3.4 Checking axial clearance of camshafts

Special tools and workshop equipment required

- ◆ Universal dial gauge bracket -VW 387-

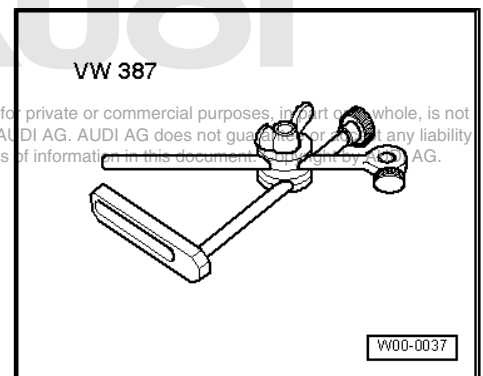

Protected by copyright. Copying for private or commercial purposes, in part or whole, is not permitted unless authorised by AUDI AG. AUDI AG does not guarantee or accept any liability with respect to the correctness of information in this document. Copyright by AUDI AG.



◆ Dial gauge -VAS 6079-

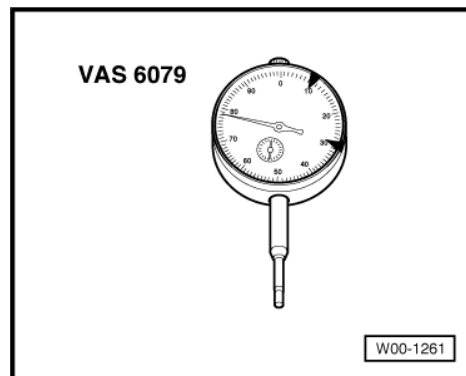

Test sequence

- Perform measurement with retaining frame removed.
- Fit camshaft to be tested in retaining frame.
- Attach dial gauge -VAS 6079- with dial gauge bracket - VW 387- to cylinder head.
- Press camshaft against dial gauge by hand.
- Set dial gauge to "0".
- Press camshaft away from dial gauge and read off value:
- Axial clearance: 0.05 ... 0.17 mm

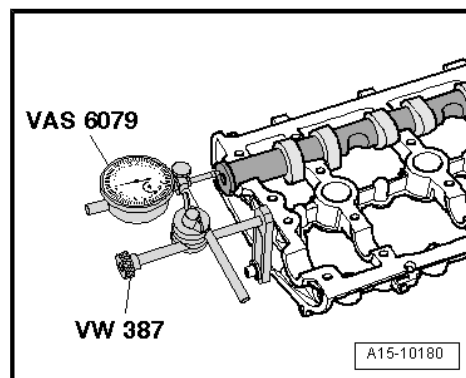

3.5 Renewing valve stem oil seals

(with cylinder head installed)



Protected by copyright. Copying for private or commercial purposes, in part or in whole, is not permitted unless authorised by AUDI AG. AUDI AG does not guarantee or accept any liability with respect to the correctness of information in this document. Copyright by AUDI AG.

Special tools and workshop equipment required

- ◆ Spark plug socket and extension -3122 B-
- ◆ Valve stem seal puller -3364-
- ◆ Valve stem seal fitting tool -3365-
- ◆ Adapter -T40012-
- ◆ Torque wrench -V.A.G 1331-
- ◆ Removal / installing device for valve cotter -VAS 5161- with guide plate for 2.0 ltr. and 3.0 ltr. FSI engine -VAS 5161/19A-

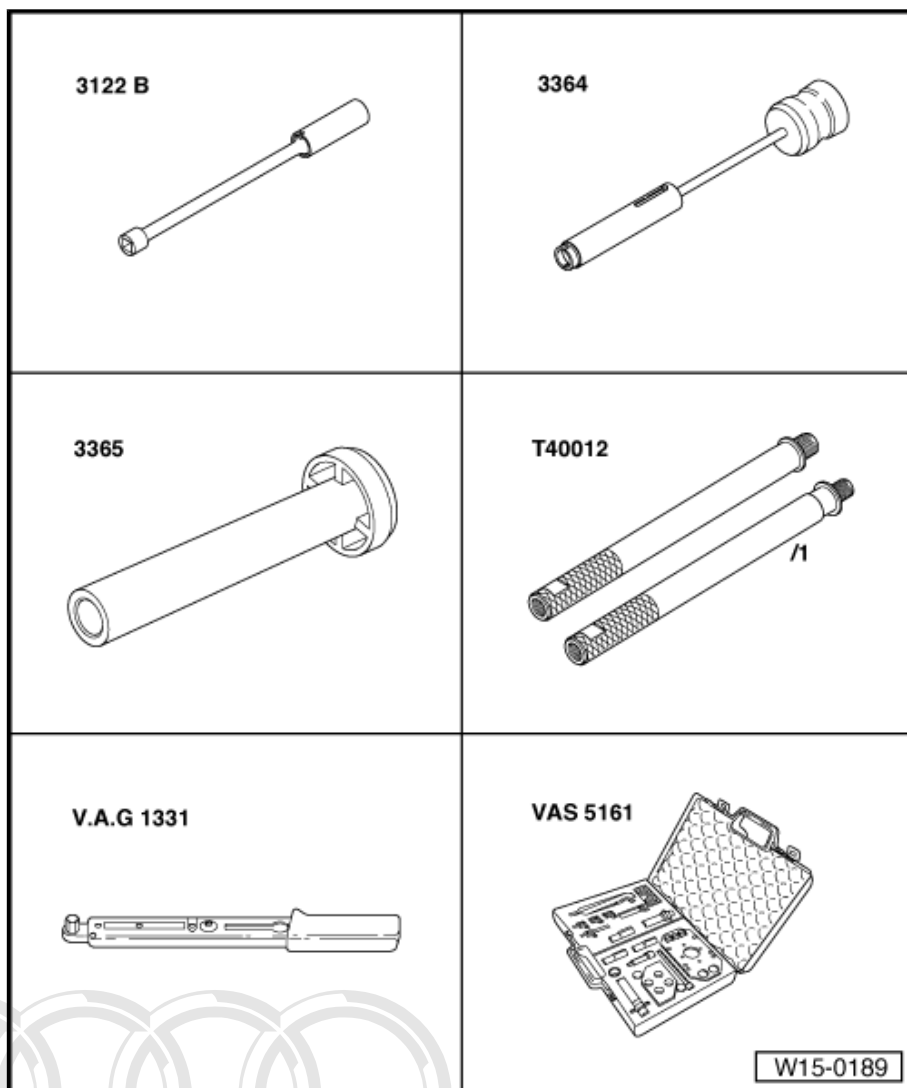
**Removing valve stem oil seals**

- Remove the camshafts. => [page 103](#)

**Note**

In order to renew the valve stem oil seals of exhaust valves of cylinder 3 and cylinder 4, the exhaust gas recirculation valve - N18- must also be removed.

Copyright © Audi AG. Copying for private or commercial purposes, in part or in whole, is not permitted unless authorised by AUDI AG. AUDI AG does not guarantee or accept any liability with respect to the correctness of information in this document. Copyright by AUDI AG.

- Remove roller rocker fingers and place onto a clean surface. When doing so, make sure that roller rocker fingers are not interchanged.
- Remove spark plugs with spark plug socket -3122 B- .



- Secure guide plate for 2.0 ltr. and 3.0 ltr. FSI engine -VAS 5161/19A- with knurled screws -VAS 5161/12- to cylinder head as shown.
- Set piston of the respective cylinder to "bottom dead centre".
- Screw adapter -T40012- into spark plug hole and connect to compressed air supply of at least 6 bar.

Protected by copyright. Copying for private or commercial purposes, in part or in whole, is not permitted unless authorised by AUDI AG. AUDI AG does not guarantee the accuracy of the information with respect to the correctness of information in this document. Copyright by AUDI AG.

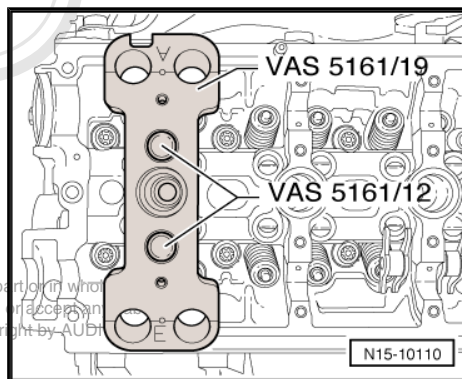

- Knock loose sticking valve cotters using punch -VAS 5161/3- and a plastic-headed hammer.

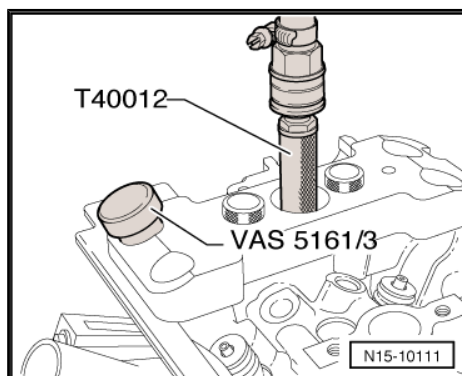

- Screw snap-in device -VAS 5161/6- with engaging fork -VAS 5161/5- into guide plate for 2.0 ltr. and 3.0 ltr. FSI engine -VAS 5161/19A- .
- Insert assembly cartridge -VAS 5161/8- into guide plate for 2.0 ltr. and 3.0 ltr. FSI engine -VAS 5161/19A- .
- Attach pressure fork -VAS 5161/2- to snap-in device -VAS 5161/6- .

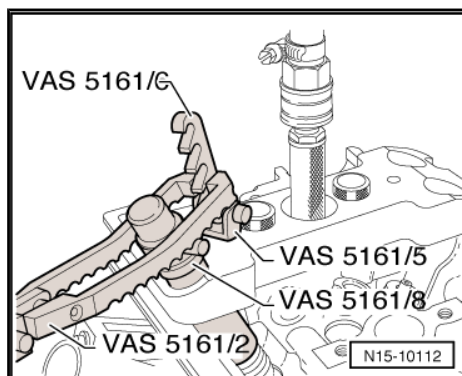

Note

Attach pressure fork -VAS 5161/2- to exhaust side as shown.

- Press down assembly cartridge -VAS 5161/8- . At the same time, turn knurled screw of assembly cartridge -VAS 5161/8- clockwise until ends engage in valve cotters.
- Move knurled screw back and forth slightly; the valve cotters are thus forced apart and taken up by the assembly cartridge.
- Release the pressure fork -VAS 5161/2- .
- Remove assembly cartridge -VAS 5161/8- .

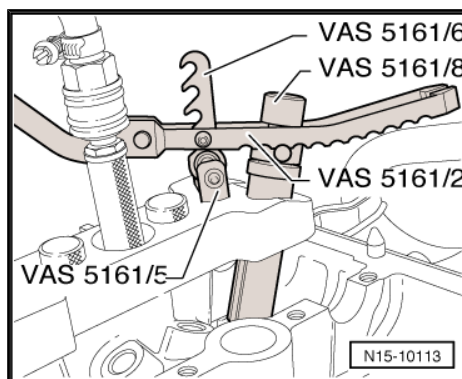

- Pull off valve stem oil seal with valve stem seal puller -3364- .

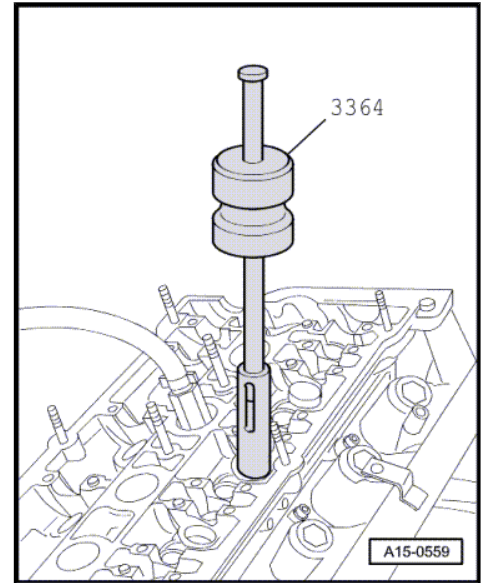

- If valve stem seal puller -3364- cannot be used on account of restricted space, knock out pin -arrow- with a punch and remove the impact extractor attachment.

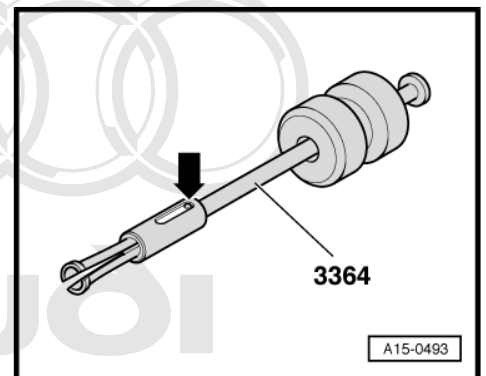

- Position lower part of valve stem seal puller -3364- on valve stem oil seal.
- Insert a punch -1- through hole in lower section of puller.
- Apply assembly lever to puller and pull out valve stem oil seal -arrow-.

Installing valve stem oil seals

- To prevent damage to the new valve stem seals -B-, attach plastic sleeve -A- to valve stem.
- Lubricate sealing lip of valve stem oil seal -B-, place it in the valve stem oil seal fitting tool -3365- and push carefully onto valve guide.
- Remove plastic sleeve -A-.
- Insert valve spring and valve spring plate.
- Set up disassembly and assembly tool -VAS 5161- as shown.

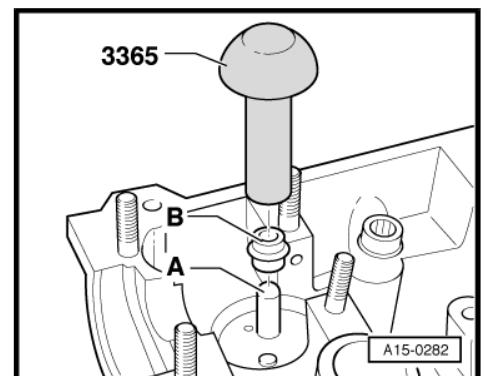
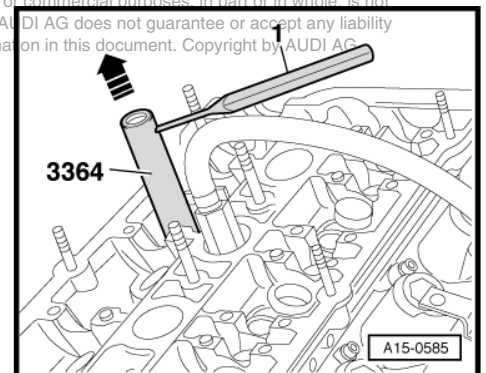

Inlet side

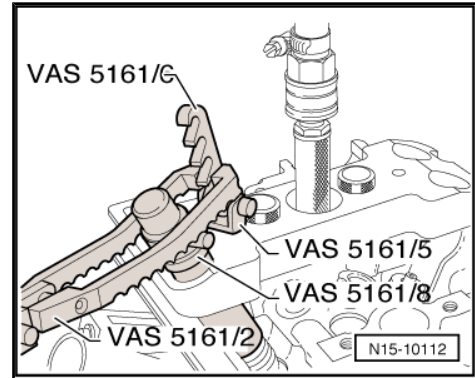

Exhaust side

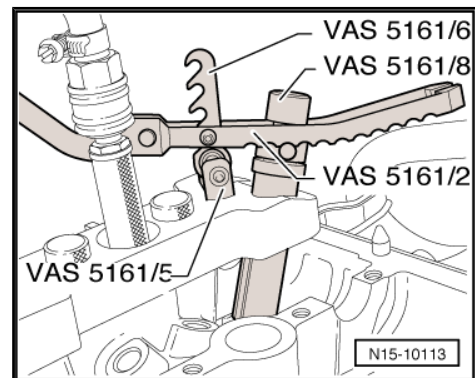

Note

- ◆ If valve cotters have been removed from assembly cartridge, they need to be put into insertion device -VAS 5161/18- first.
- ◆ Press assembly cartridge -VAS 5161/8- onto insertion device from above and pick up valve cotters.

- Press down assembly cartridge -VAS 5161/8- with pressure fork -VAS 5161/2- and pull knurled screw of assembly cartridge up, at the same time turning it in both directions.
- Release the pressure fork -VAS 5161/2- with knurled screw still in pulled-out position.
- Remove disassembly and assembly tool -VAS 5161- .

Further assembly is basically carried out in reverse order of dismantling.

- Installing camshafts ⇒ [page 103](#) .

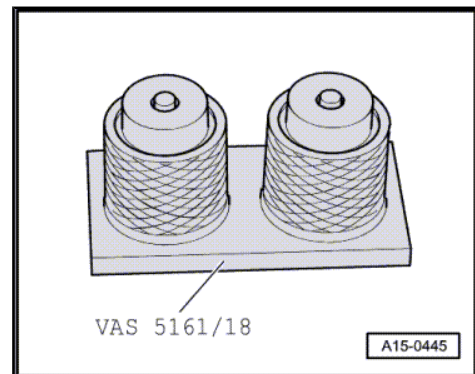

3.6 Checking valve guides

Special tools and workshop equipment required

◆ Universal dial gauge bracket -VW 387-

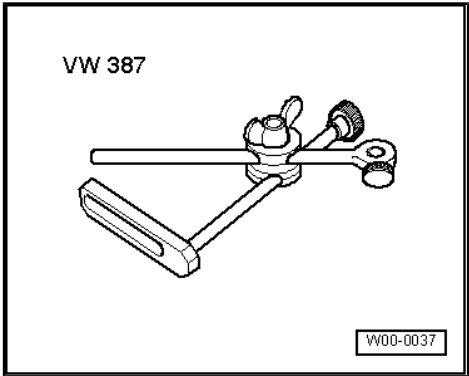

◆ Dial gauge -VAS 6079-

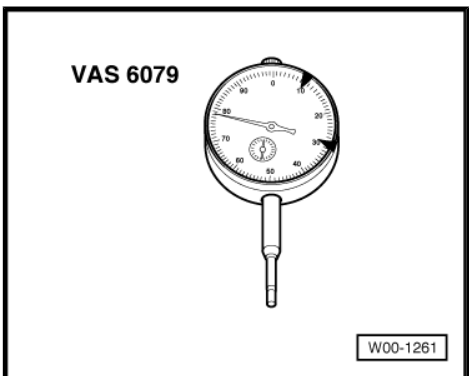

Test sequence

- Insert valve into guide. Valve stem end must be flush with guide. Only insert inlet valve into inlet guide and exhaust valve into exhaust guide, as the stem diameters are different.
- Measure the amount of sideways play.

Wear limit

Inlet valve guide	Exhaust valve guide
0.80 mm	0.80 mm

Note

- ◆ *If the wear limit is exceeded, repeat the measurement with new valves. Renew cylinder head if wear limit is still exceeded.*
- ◆ *If the valve has to be renewed as part of a repair, use a new valve for the measurement.*

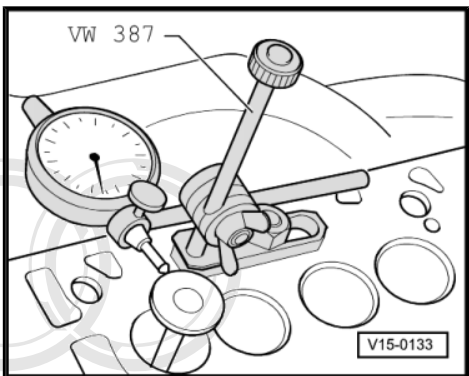

Protected by copyright. Copying for private or commercial purposes, in part or in whole, is not permitted unless authorised by AUDI AG. AUDI AG does not guarantee or accept any liability with respect to the correctness of information in this document. Copyright by AUDI AG.



3.7 Renewing exhaust camshaft oil seal

Special tools and workshop equipment required

- ◆ Oil seal extractor -2085-
- ◆ Assembly tool -3036-
- ◆ Assembly tool -T10071-
- ◆ Puller -T40001-

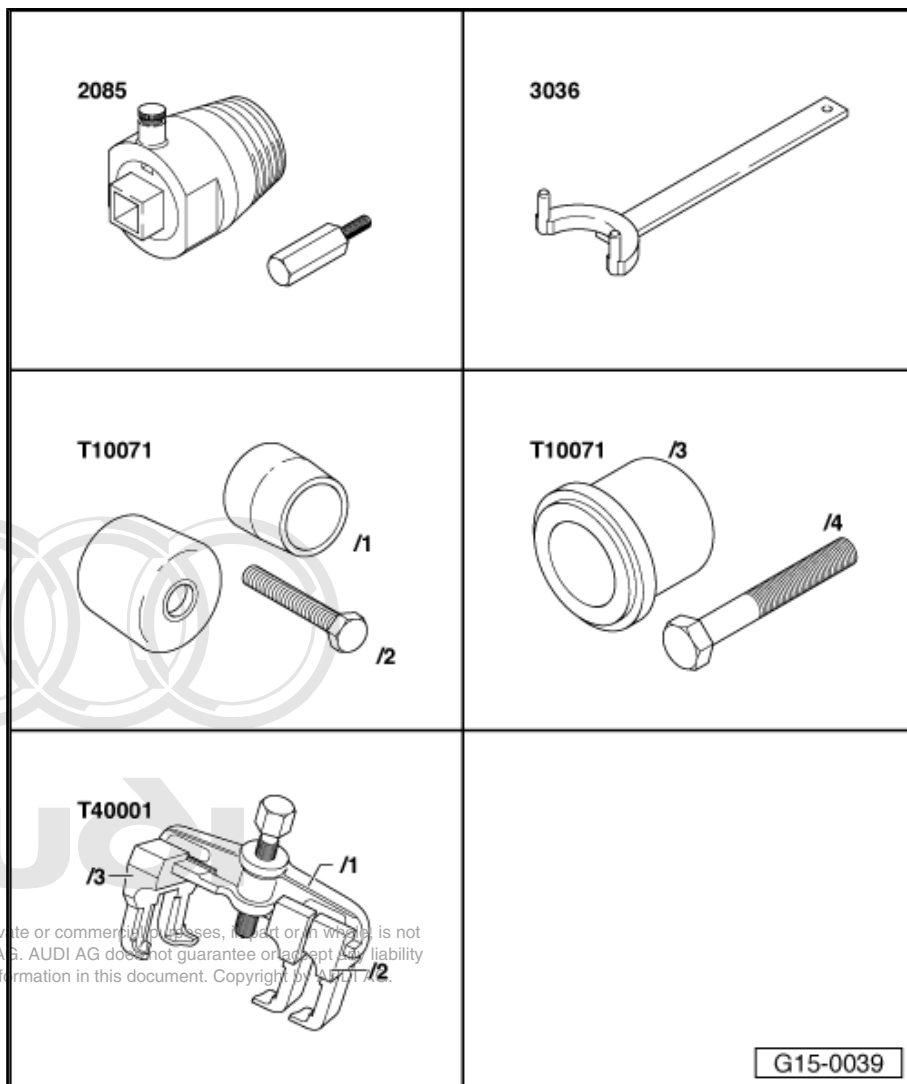

Protected by copyright. Copying for private or commercial purposes, in part or in whole, is not permitted unless authorised by AUDI AG. AUDI AG does not guarantee or accept any liability with respect to the correctness of information in this document. Copyright by AUDI AG.

Pin wrench -T10020-

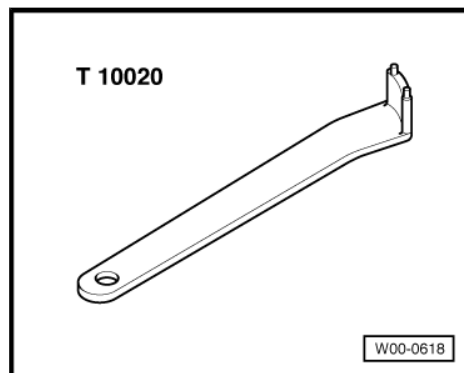

Locking pin -T10060A-
Removing

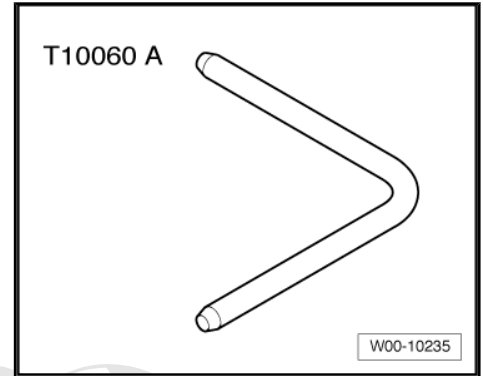

- Unplug electrical connector at air mass meter -G70- -3-.
- Open clamps -1 and 2- and disconnect air intake hose from air mass meter.
- Detach air intake connection at lock carrier -4-.
- Pull off engine cover panel.

 **WARNING**
Hot steam/hot coolant may escape when opening expansion tank. Cover cap with cloth and open carefully.

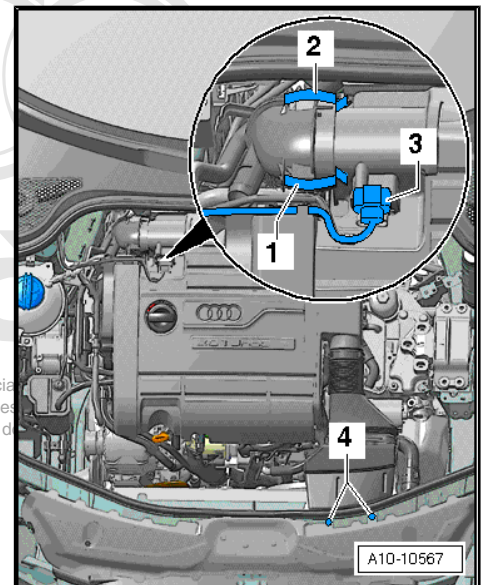

- Open filler cap on coolant expansion tank

- Remove centre noise insulation -fasteners 1 ... 4-.

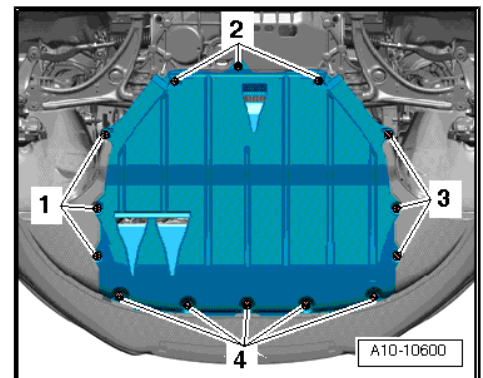

- Remove right noise insulation -arrows-.

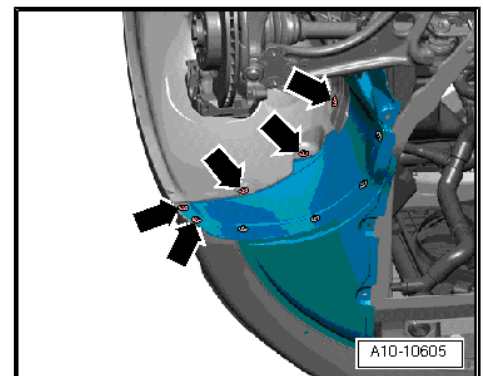



- Remove noise insulation frame -arrow-.
- Drain off coolant => [page 147](#)
- Remove toothed belt => [page 66](#)

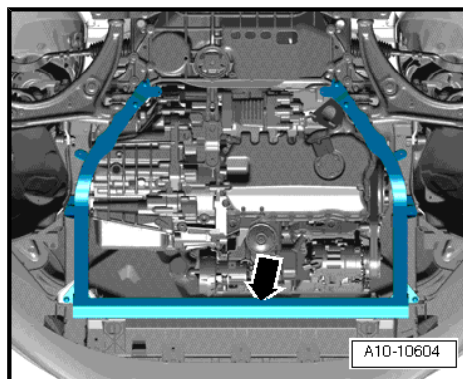

- Loosen camshaft sprocket (apply counterhold tool -3036-).

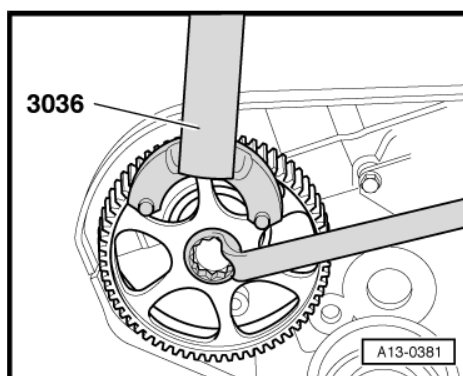

- Detach the camshaft sprocket using puller -T40001- and claws T40001/6 and T40001/7.

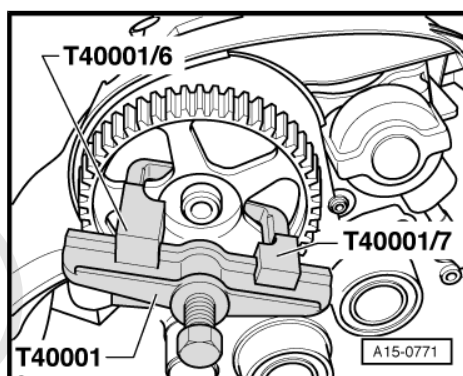

- To guide oil seal extractor, screw special tool 2085/2 from oil seal extractor -2085- by hand into camshaft as far as it will go.
- Unscrew inner part of oil seal extractor -2085- two turns (approx. 3 mm) from the outer part and lock in position with the knurled screw.

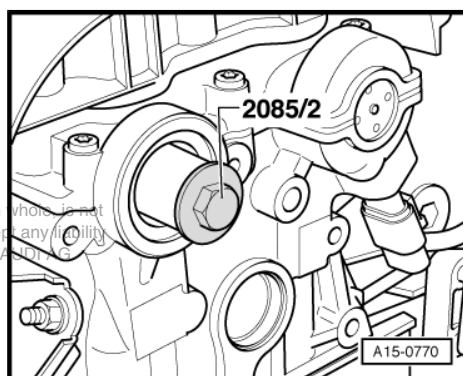

Protected by copyright. Copying for private or commercial purposes, in part or in whole, is not permitted unless authorised by AUDI AG. AUDI AG does not guarantee or accept any liability with respect to the correctness of information in this document. Copyright by Audi AG

- Lubricate threaded head of oil seal extractor -2085- , place it in position and, while exerting firm pressure, screw it into oil seal as far as possible.
- Loosen knurled screw and turn inner part of extractor against camshaft until oil seal has been extracted.
- Clamp flats of oil seal extractor in vice. Remove oil seal with pliers.

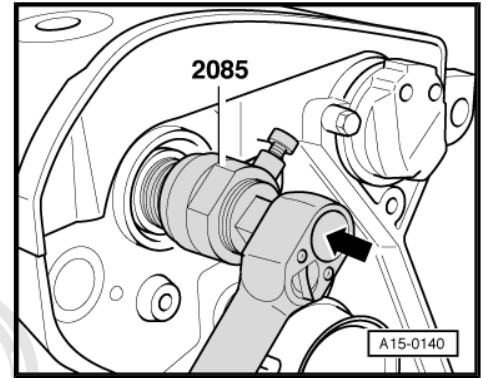

Installing

- Tightening torques ⇒ [page 98](#)
- Do not lubricate sealing lip of oil seal.
- Fit guide sleeve -T10071/1- from assembly tool -T10071- onto camshaft journal.
- Push oil seal over guide sleeve onto shaft.
- Detach guide sleeve.

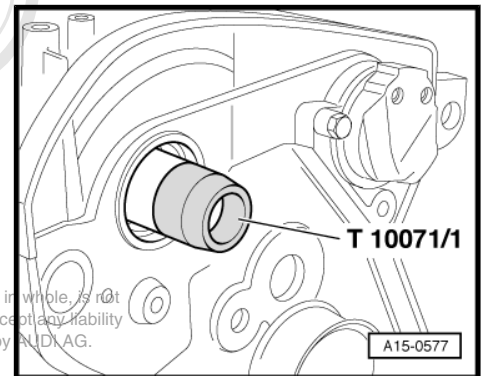

Protected by copyright. Copying for private or commercial purposes, in part or in whole, is not permitted unless authorised by AUDI AG. AUDI AG does not guarantee or accept any liability with respect to the correctness of information in this document. Copyright by AUDI AG.

- Press in oil seal all the way using guide sleeve -T10071/3- and bolt -T10071/4- from assembly tool -T10071- .

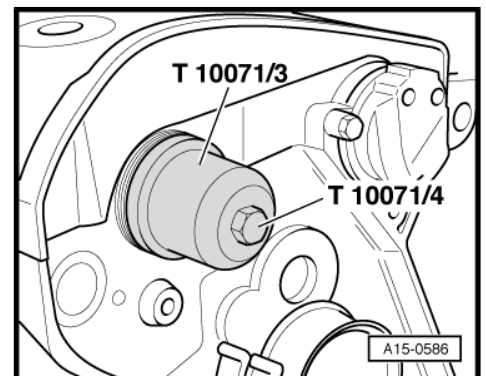

- Install camshaft sprocket.
- ◆ Check installation position: The thinner web of the camshaft sprocket faces outwards -arrows- and the marking for No. 1 cylinder TDC is visible.

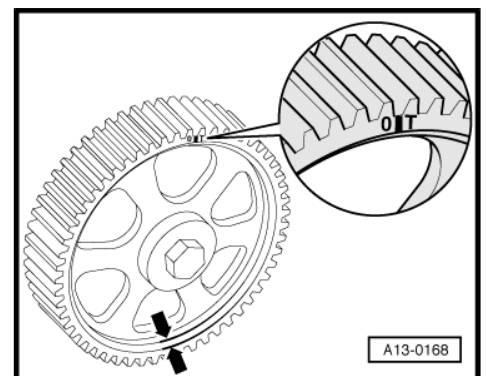



- Fit securing bolt of camshaft sprocket (use counterhold -3036-).



Note

If a piston is at TDC the valves could strike the piston when turning the camshaft. Pistons must therefore not be at TDC This could otherwise result in damage to valves and pistons.

- Install toothed belt => [page 66](#) .

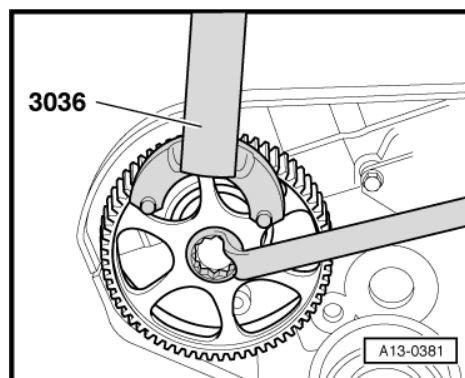

Protected by copyright. Copying for private or commercial purposes, in part or in whole, is not permitted unless authorised by AUDI AG. AUDI AG does not guarantee or accept any liability with respect to the correctness of information in this document. Copyright by AUDI AG.

17 – Lubrication

1 Oil pump and sump

i Note

If large quantities of metal shavings or other particles are found in the engine oil when repairing the engine (possibly caused by partial seizure of crankshaft and conrod bearings), clean the oil passages thoroughly and renew the oil cooler to prevent further damage occurring later.

Checking oil pressure ⇒ [page 141](#)

Viscosity grades and oil specifications: ⇒ [Maintenance ; Booklet 810](#)
permitted unless authorised by AUDI AG. AUDI AG does not guarantee or accept any liability with respect to the correctness of information in this document. Copyright by AUDI AG.

Oil capacities: ⇒ Exhaust emissions test

1.1 Sump - exploded view

Balance shaft assembly with oil pump ⇒ [page 125](#)

Oil filter bracket ⇒ [page 132](#)

1 - Bolt

- Tightening sequence ⇒ [page 40](#)

2 - Oil dipstick

- The oil level must not be above max. mark.

3 - Guide tube for oil dipstick

4 - Guide tube

5 - Spacer plate

6 - Balance shaft assembly with oil pump

- With pressure relief valve (12 bar)
- Note the centring sleeves ⇒ [page 125](#)
- Balance shaft assembly with oil pump - exploded view ⇒ [page 125](#)
- Removing and installing ⇒ [page 127](#)

7 - Bolt

- Renew
- Note different bolt lengths ⇒ [page 127](#)
- Tightening sequence ⇒ [page 127](#)

8 - Bolt

- Tightening sequence ⇒ [page 120](#)

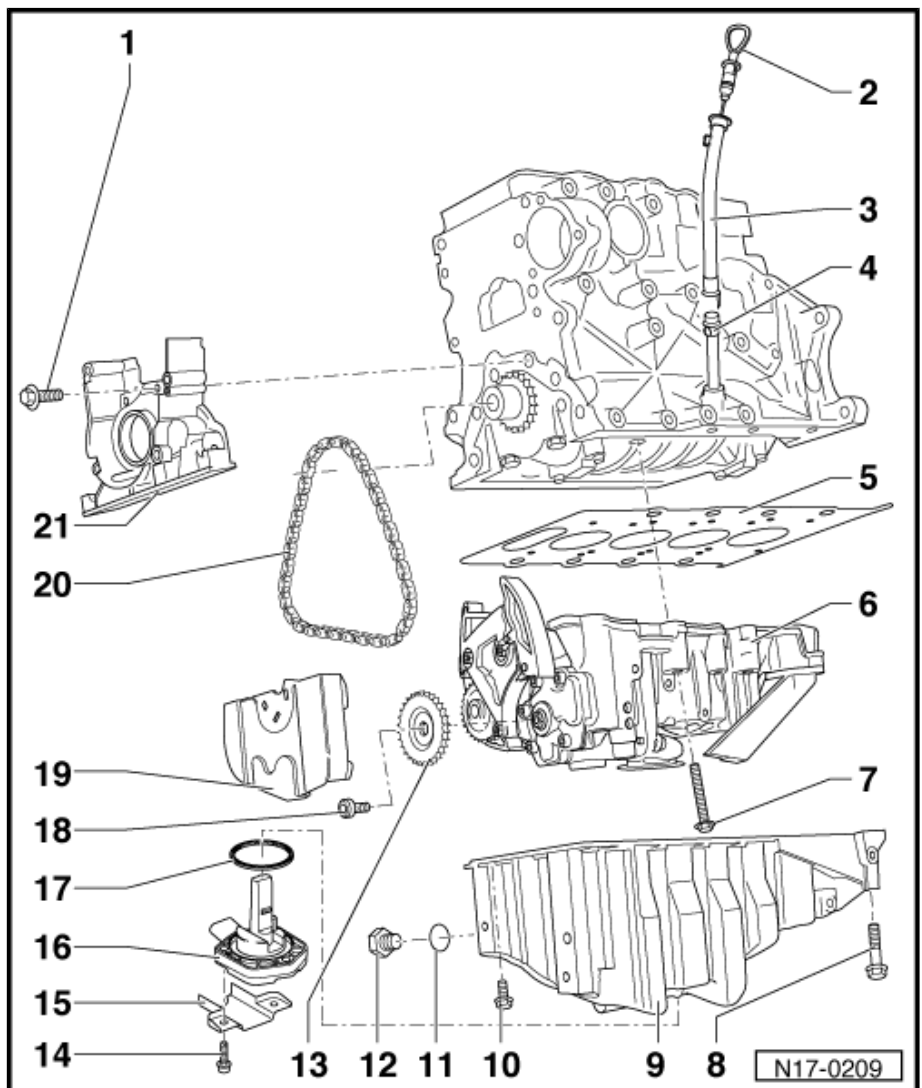



9 - Sump

- Clean sealing surface before installing
- Removing and installing ⇒ [page 120](#)

10 - Bolt

- Tightening sequence ⇒ [page 120](#)

11 - Seal

- Attached to ⇒ [Item 12 \(page 120\)](#) .

12 - Oil drain plug

- 30 Nm
- With captive seal
- Renew

13 - Chain sprocket

14 - Bolt

- 10 Nm

15 - Protective cap

16 - With oil level/oil temperature sender -G266-

17 - Seal

- Renew
- Lubricate before installing

18 - Bolt

- 20 Nm + turn 90° further
- Renew

19 - Chain guard

20 - Chain

21 - Sealing flange (front)

- Must be positioned on dowel pins

Removing and installing ⇒ [page 44](#)



Protected by copyright. Copying for private or commercial purposes, in part or in whole, is not permitted unless authorised by AUDI AG. AUDI AG does not guarantee or accept any liability with respect to the correctness of information in this document. Copyright by AUDI AG.

Tightening sequence for sump

– Proceed as follows:

1. Tighten bolts -1...20- securing sump to cylinder block in diagonal sequence initially to 5 Nm.
2. Tighten sump/gearbox bolts -arrows- to 40 Nm.
3. Tighten bolts securing sump to cylinder block in diagonal sequence to 15 Nm.

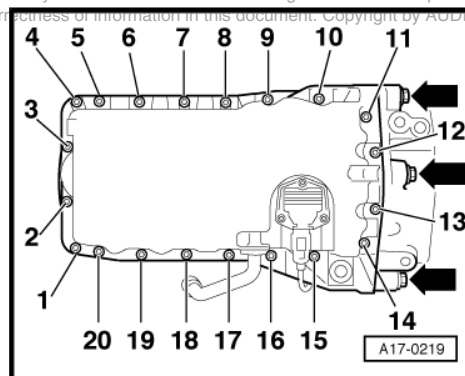

1.2 Removing and installing sump

Special tools and workshop equipment required

- ◆ Allen key (long reach) -T10058-

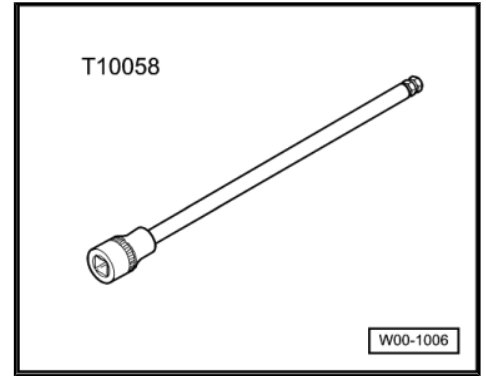

- ◆ Electric drill with plastic brush attachment
- ◆ Safety goggles
- ◆ Silicone sealant ⇒ Parts catalogue

Removing

- Unplug electrical connector at air mass meter -G70- -3-.
- Open clamps -1 and 2- and disconnect air intake hose from air mass meter.
- Detach air intake connection at lock carrier -4-.
- Pull off engine cover panel.

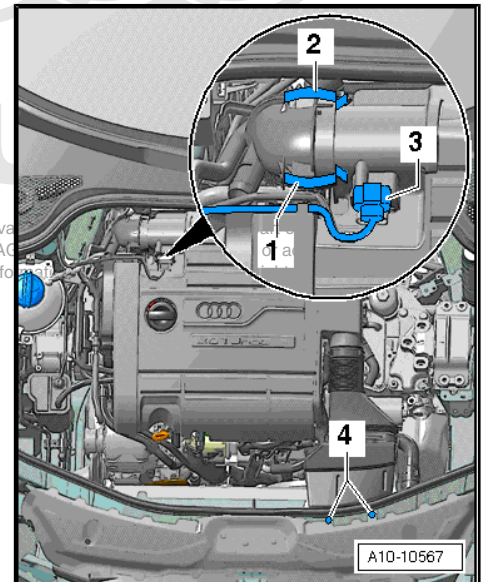

Protected by copyright. Copying for private use is permitted unless authorised by AUDI AG with respect to the correctness of info

- Remove centre noise insulation -fasteners 1 ... 4-.

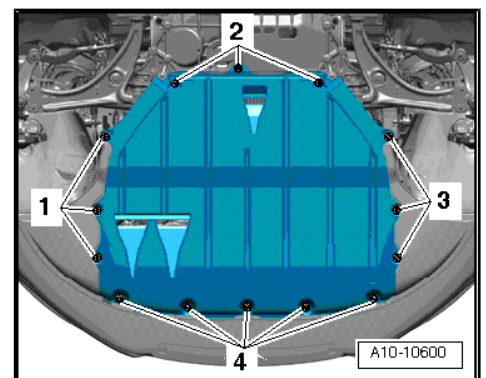



- Remove right noise insulation -arrows-.

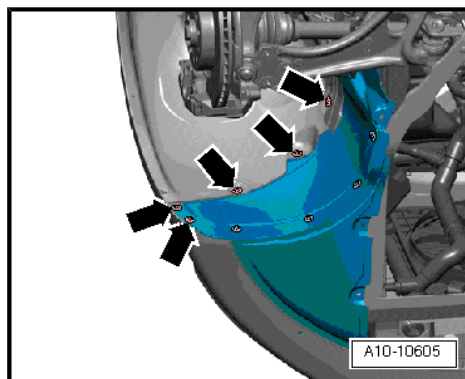

- Remove noise insulation frame -arrow-.

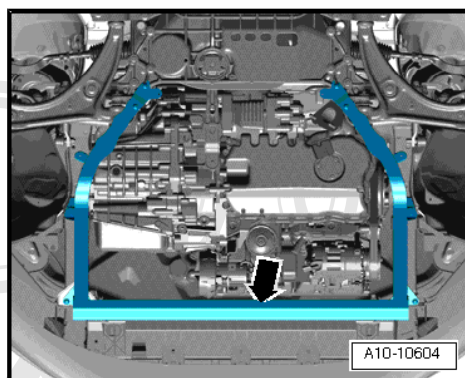

- Detach air pipe -arrow- from charge air cooler.

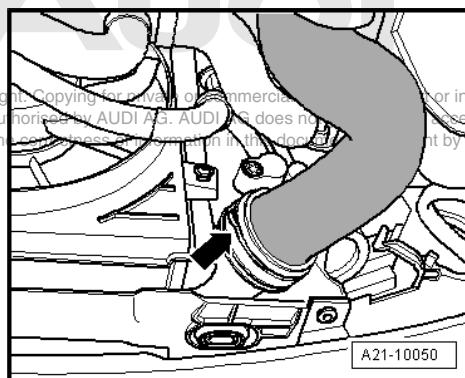

Protected by copyright. Copying or reuse for commercial purposes or in whole, is not permitted unless authorized by AUDI AG. AUDI AG does not accept any liability with respect to the correctness of the information in this document by AUDI AG.

- Unbolt air pipe from turbocharger -arrows-.

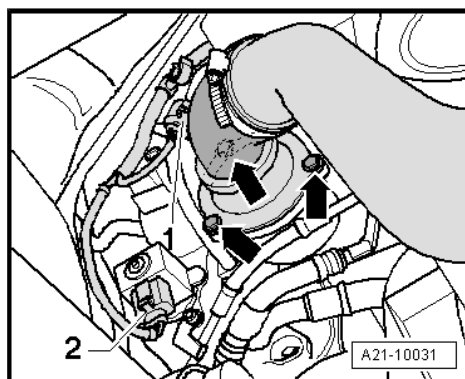

- Unscrew bolts -arrows- and remove air pipe.

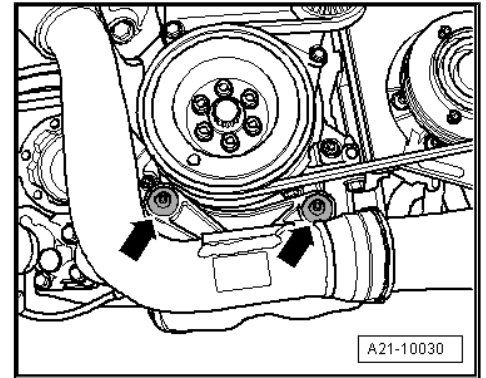

- Detach air pipe -1- from charge air cooler.
- Unplug connector from charge air pressure sender -G31- → Rep. Gr. 24 ; Overview of fitting locations .
- Remove air pipe.

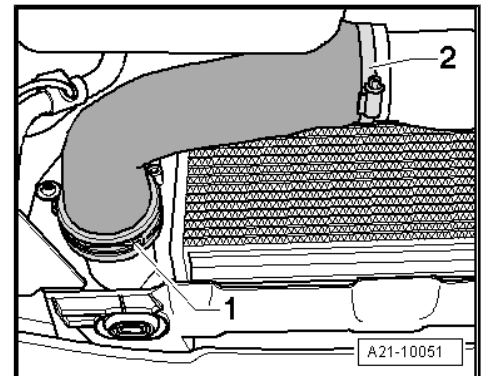

- Unplug electrical connector -1- at oil level and oil temperature sender -G266- .
- Unbolt oil return pipe from turbocharger -arrows-.
- Drain off engine oil.

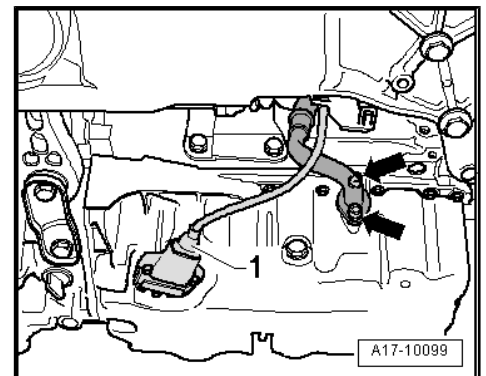

Audi

Protected by copyright. Copying for private or commercial purposes, in part or in whole, is not permitted unless authorised by AUDI AG. AUDI AG does not guarantee or accept any liability with respect to the correctness of information in this document. Copyright by AUDI AG.



- Unscrew sump/gearbox bolts -arrows-.
- Unscrew bolts -1 ... 20- in diagonal sequence.
- Take off sump: if necessary loosen it by striking lightly with a rubber hammer.

Installing

- Tightening torques => [page 119](#)
- ◆ Silicone sealant: => Parts catalogue



Note

- ◆ *Note expiry date of silicone sealant.*
- ◆ *The sump must be installed within 5 minutes after applying the silicone sealant.*
- Remove sealant residue from cylinder block using a flat scraper.



WARNING

Wear safety goggles.

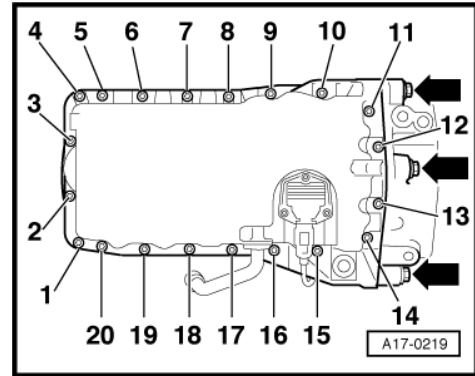

- Remove remaining sealant from sump (with rotating plastic brush or similar).
- Clean sealing surfaces; they must be free of oil and grease.

Protected by copyright. Copying for private or commercial purposes is not permitted unless authorised by AUDI AG. AUDI AG does not guarantee with respect to the correctness of information in this document. AUDI AG.

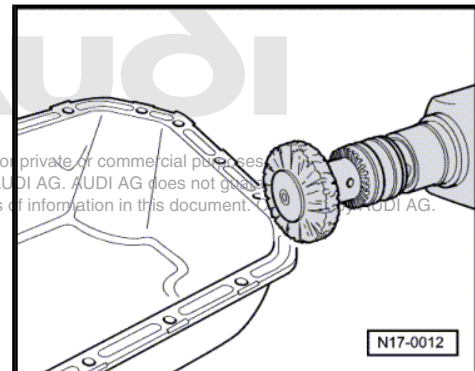

- Cut off nozzle of tube at front marking (Ø of nozzle approx. 3 mm).

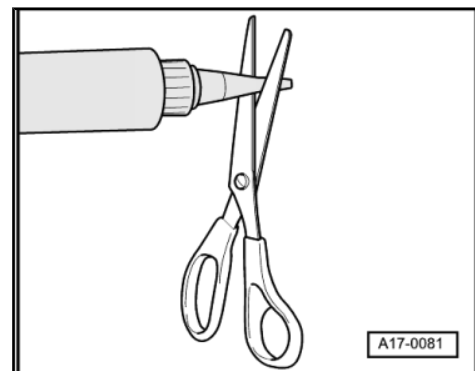

- Apply the bead of silicone sealant onto the clean sealing surface of the sump, as illustrated.
- ◆ Thickness of sealant bead: 2 ... 3 mm

 **Note**

- ◆ *The sump must be installed within 5 minutes after applying the silicone sealant.*
 - ◆ *The bead of sealant must not be thicker than specified, otherwise excess sealant can enter the sump and obstruct the strainer in the oil intake pipe.*
 - ◆ *Be particularly careful when applying the bead of sealant around the rear sealing flange (arrows in illustration).*
- Fit sump immediately and tighten bolts as follows; tightening sequence ⇒ [page 120](#)

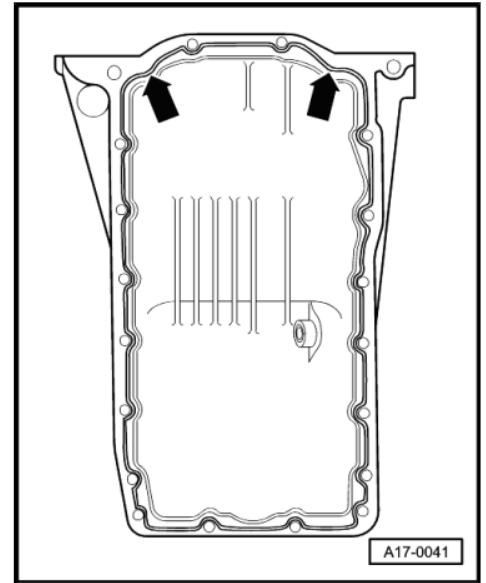

 **Note**

- ◆ *When installing sump with engine removed from vehicle, ensure that sump is positioned flush with cylinder block at fly-wheel end.*
 - ◆ *After fitting sump assembly, the sealant must dry for approx. 30 minutes. Then (and only then) fill the engine with engine oil.*
- Fill up with engine oil and check oil level.

The remaining installation steps are carried out in the reverse sequence. Note the following points:

- Installing air pipes with connectors ⇒ [page 164](#)

1.3 Balance shaft assembly with oil pump - exploded view

Balance shaft assembly ⇒ [page 119](#)

Oil filter bracket ⇒ [page 132](#)



Audi

Protected by copyright. Copying for private or commercial purposes, in part or in whole, is not permitted unless authorised by AUDI AG. AUDI AG does not guarantee or accept any liability with respect to the correctness of information in this document. Copyright by AUDI AG.

**1 - Chain guard****2 - Chain**

- Before removing, mark running direction (fitting position) with paint

3 - Dowel sleeves**4 - Spacer plate****5 - Balance shaft assembly with oil pump**

- Before installing, check that the two dowel sleeves for centring oil pump/cylinder block are fitted
- Removing and installing ⇒ [page 127](#)

6 - Bolt

- 9 Nm

7 - Cover

- Prevents foam build-up in engine oil

8 - Bolt

- 40 Nm

9 - Bolt

- 8 Nm

10 - Oil intake pipe

- Clean strainer if dirty

11 - O-ring

- Renew

12 - Bolt

- Renew
- Note different bolt lengths ⇒ [page 127](#)
- Tightening sequence ⇒ [page 127](#)

13 - Bolt

- Renew
- Note different bolt lengths ⇒ [page 127](#)
- Tightening sequence ⇒ [page 127](#)

14 - Outer rotor

- Check contact surfaces for scores
 - Marking must be visible
- Protected by copyright. Copying for private or commercial purposes, in part or in whole, is not permitted without the written permission of AUDI AG. AUDI AG does not guarantee or accept any liability with respect to the correctness of information in this document. Copyright by AUDI AG.

15 - Inner rotor

- Check contact surfaces for scores

16 - Oil pump cover**17 - Chain sprocket****18 - Bolt**

- 20 Nm + turn 90° further
- Renew

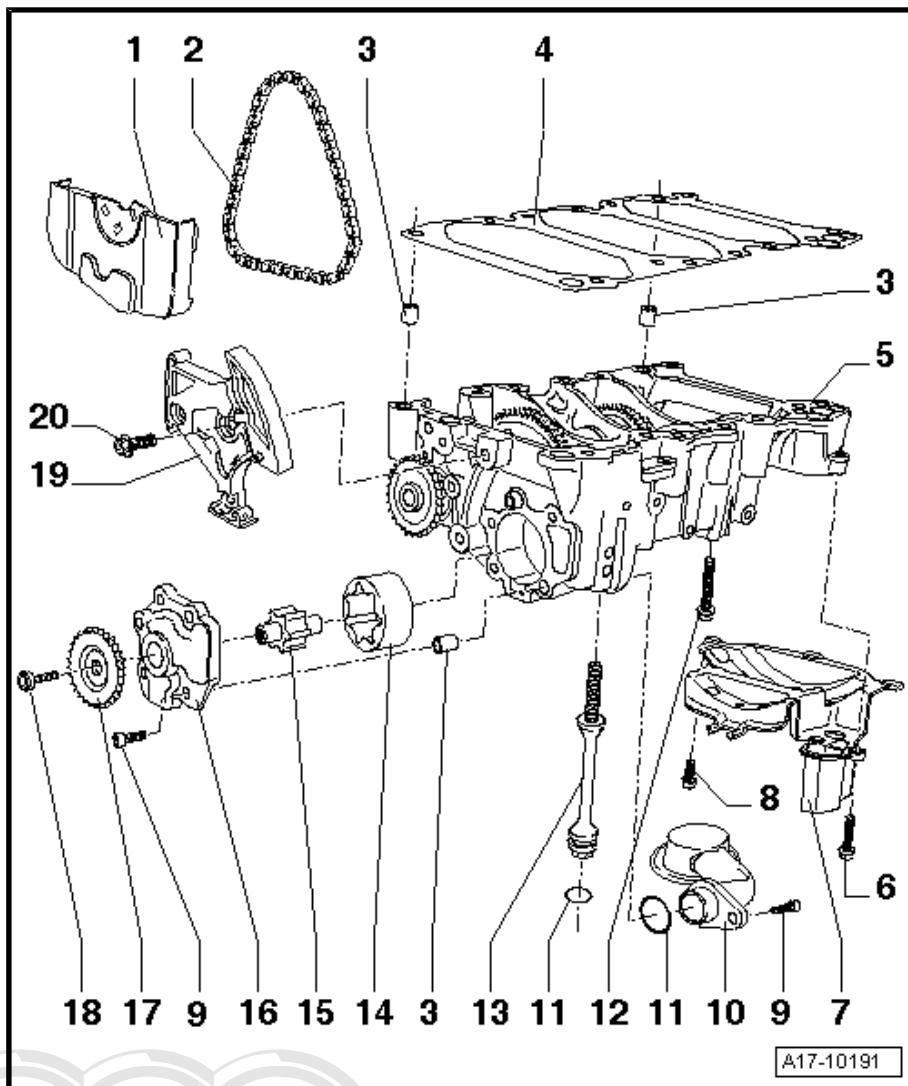

19 - Chain tensioner with tensioning rail

- ❑ Pre-tensioning before installing ⇒ [page 131](#)

20 - Bolt

- ❑ 15 Nm

Positions of bolts for balance shaft housing

- A - Hexagon collared bolt M7x40
- B - Hexagon collared bolt M7x70
- C - Hexagon collared bolt M7x90
- D - Hexagon collared bolt M7x55
- E - Screw plug with O-ring

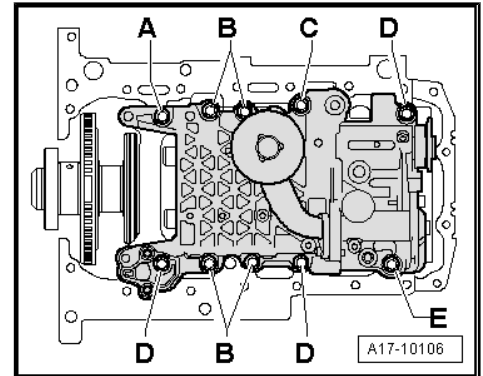

Tightening sequence for balance shaft housing

- Proceed as follows:
 1. Screw in bolts -arrows- hand-tight.
 2. Tighten bolts -arrows- to 15 Nm in diagonal sequence starting from inside and working outwards.
 3. Turn bolts -arrows- 90° further (1/4 turn) in diagonal sequence starting from inside and working outwards using a rigid wrench.

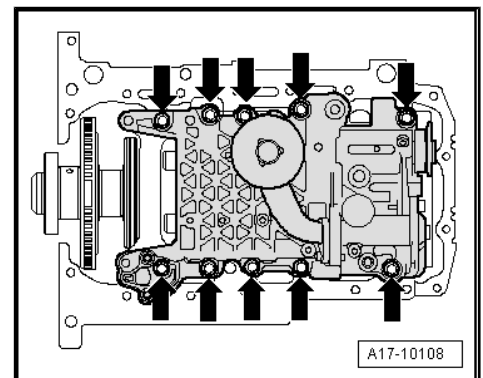

1.4 Removing and installing balance shaft assembly with oil pump

Special tools and workshop equipment required

- ◆ Locking pin -T10027-

Protected by copyright. Copying for private or commercial purposes, in part or in whole, is not permitted unless authorised by AUDI AG. AUDI AG does not guarantee or accept any liability with respect to the correctness of information in this document. Copyright by AUDI AG.

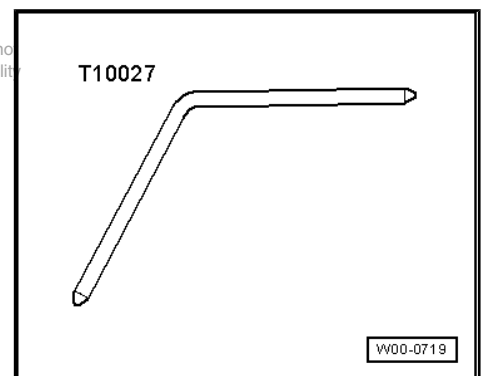

Removing

- Remove sump ⇒ [page 120](#) .



WARNING

The engine must only be turned at the crankshaft, in the direction of normal engine rotation (clockwise).



Note

Apply spanner to central bolt of crankshaft for turning engine.

- Set camshaft sprocket to TDC marking by turning crankshaft. Marking on camshaft sprocket must align with arrow on toothed belt cover.

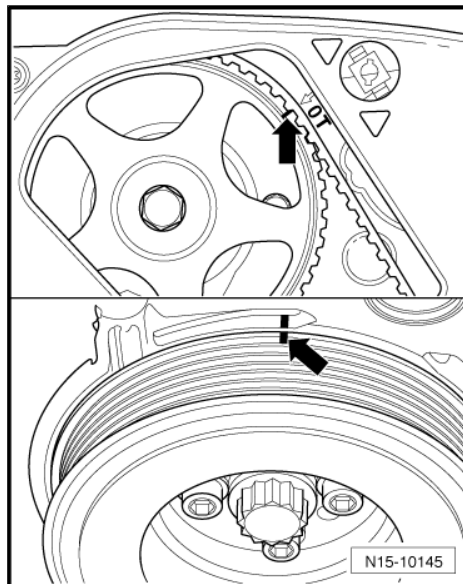

- Pull off chain guard. Retaining tabs can be released with a small screwdriver (insert in openings -arrows-).

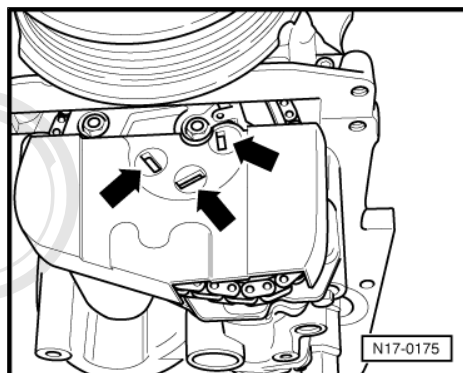

- Loosen bolt on oil pump chain sprocket. Counterhold on central bolt of vibration damper.

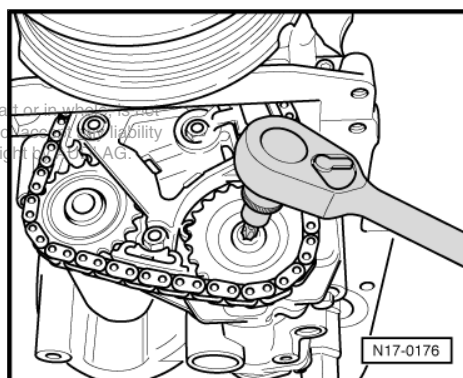

Protected by copyright. Copying for private or commercial purposes, in part or in whole, is not permitted unless authorised by AUDI AG. AUDI AG does not guarantee correctness or liability with respect to the correctness of information in this document. Copyright © 2006 AUDI AG.

- Use screwdriver to slacken chain rail -arrow- and lock it in position using a 3 mm Allen key -1-.

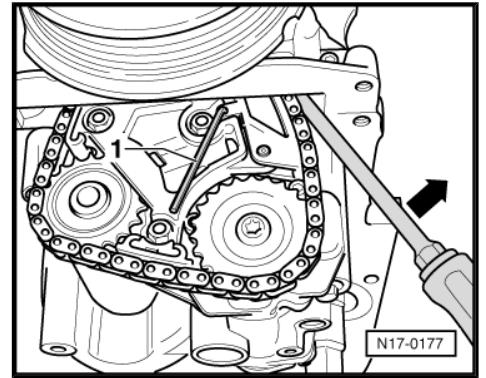

- Detach oil pump chain sprocket and disengage chain at balance shaft drive.



Protected by copyright. Copying for private or commercial purposes, in part or in whole, is not permitted unless authorised by AUDI AG. AUDI AG does not guarantee or accept any liability with respect to the correctness of information in this document. Copyright by AUDI AG

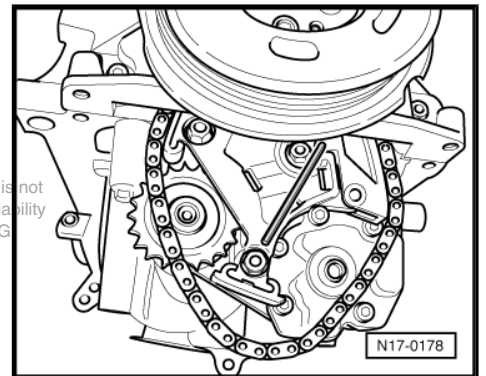

- Remove baffle plate by unscrewing bolts -1 and 2-.

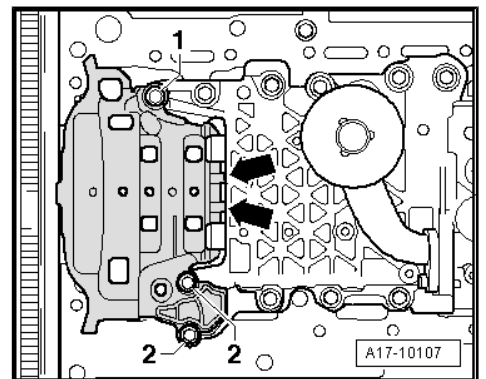

- Loosen bolts -arrows- on balance shaft assembly, working from outside inwards, and then remove balance shaft assembly.

Installing

- Tightening torques ⇒ [page 125](#)
- Chain tensioner must be pre-tensioned ⇒ [page 131](#) .
- Renew all bolts on balance shaft assembly.
- Renew seal on bolt for balance shaft assembly ⇒ [Item 13 \(page 126\)](#) .

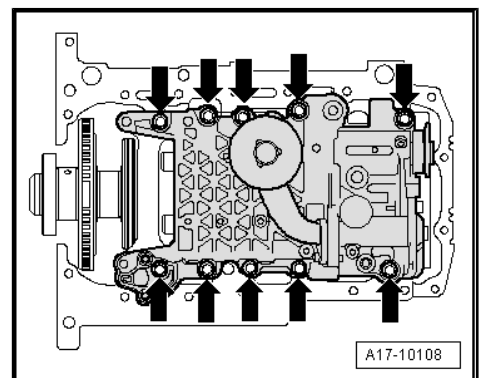



- Fit spacer plate onto dowel sleeves on balance shaft assembly as shown -arrows-.

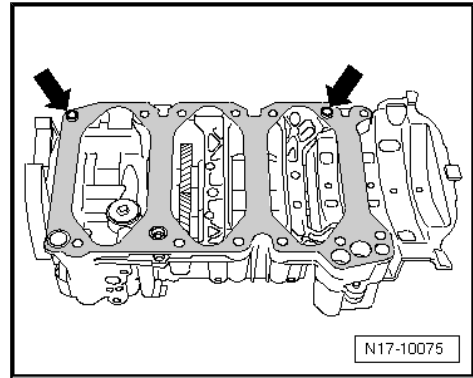
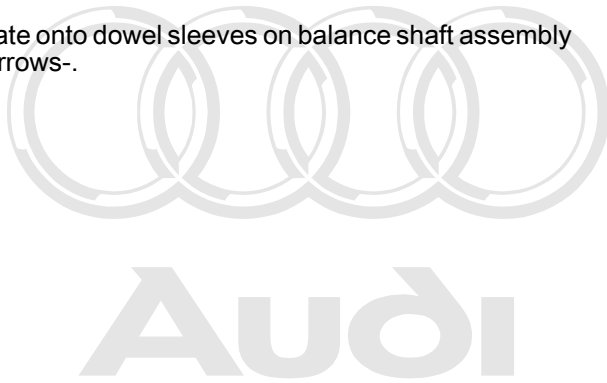

- Install balance shaft assembly with oil pump and spacer plate. Tighten securing bolts -arrows- working from inside outwards.

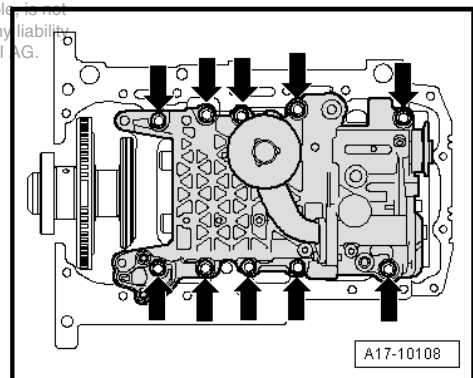

Note

- ◆ Note different bolt lengths. => [page 127](#)
- ◆ Note tightening sequence => [page 127](#)
- ◆ Note the dowel sleeves.

- Install baffle plate. To do so, insert pins in balance shaft assembly -arrows-.



Note

Apply spanner to central bolt of crankshaft for turning engine.

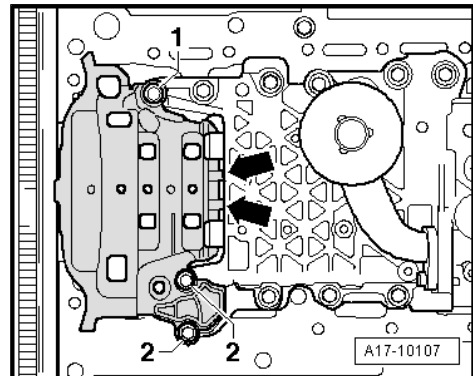

- Rotate engine to TDC of No. 1 cylinder by turning central bolt of crankshaft sprocket in normal direction of rotation. Marking on camshaft sprocket and marking on crankshaft must be aligned to TDC of cylinder No. 1 -arrows-.

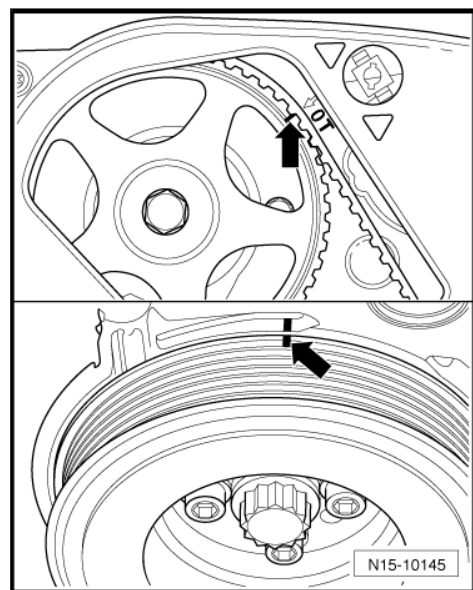

- Marking on chain sprocket of balance shaft -arrow- must be positioned opposite the locating hole. Use locking pin - T10027- to lock chain sprocket in this position. Place chain on chain sprocket of balance shaft.
- Install oil pump chain sprocket with new bolt and hand-tighten the bolt.

 **Note**

The oil pump chain sprocket can only be installed correctly in one position. When installing, you may ONLY turn the oil pump.

- Remove locking pin -T10027- and Allen key -1-. Secure oil pump chain sprocket. Counterhold on central bolt of vibration damper.

Further assembly is basically carried out in reverse order of dismantling.

- Install sump ⇒ [page 120](#) .

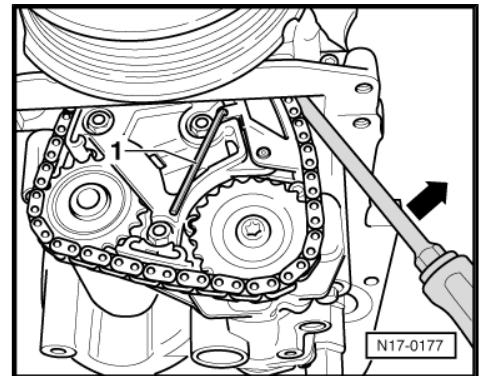
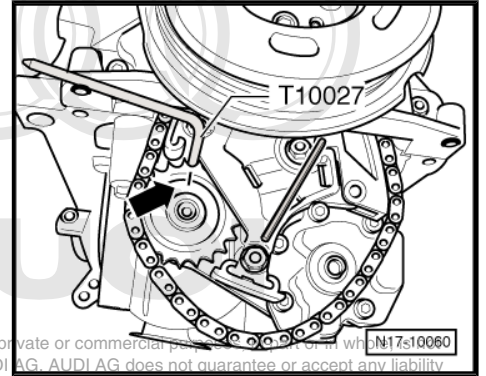

1.4.1 Pre-tensioning chain tensioner

- Pre-tension the piston by hand -arrow-.

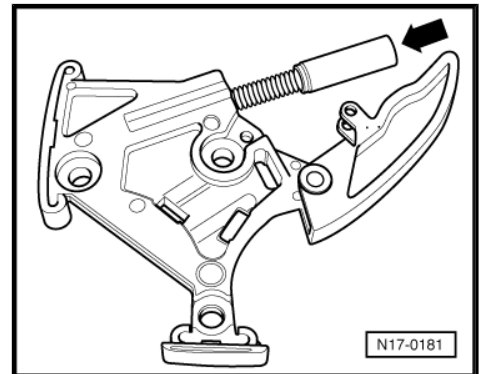

- Press chain rail in direction of arrow and lock in position using a 3 mm Allen key -1-.

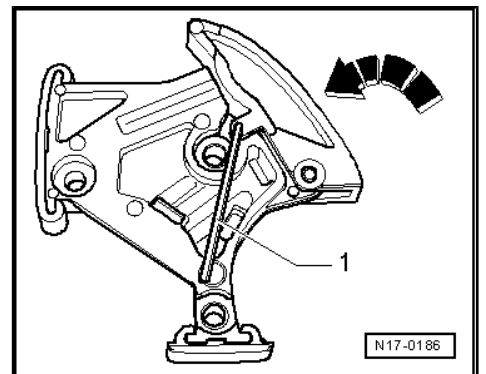

2 Oil filter bracket and oil cooler

2.1 Oil filter bracket - exploded view

Sump with balance shaft assembly ⇒ [page 119](#)

Balance shaft assembly with oil pump ⇒ [page 125](#)

1 - Pipe

- For crankcase breather

2 - Oil pressure switch -F1-

- 1.4 bar - black
- Checking ⇒ [page 141](#)
- 21 Nm

3 - Bolt

- 15 Nm
- With earth wire for oil pressure switch

4 - Bracket

5 - Bolt

- 15 Nm

6 - Oil cooler

- See note ⇒ [page 119](#)
- Ensure clearance from surrounding components
- Diagram of coolant hose connections ⇒ [page 146](#)
- Removing and installing ⇒ [page 134](#)

7 - Gasket

- Renew

8 - Oil filter housing

- Remove and install using oil filter tool 3417 or 36 mm socket, e.g. socket, 36 mm -T10125-

- Draining ⇒ [page 133](#)

9 - Screw plug

10 - Seal

- Renew
- Lubricate lightly with oil
- Installation position ⇒ [page 133](#)

11 - Oil filter element

- Observe change intervals ⇒ Maintenance ; Booklet 810

12 - Bolt

- 15 Nm

13 - Baffle plate

- Installation position ⇒ [page 133](#)

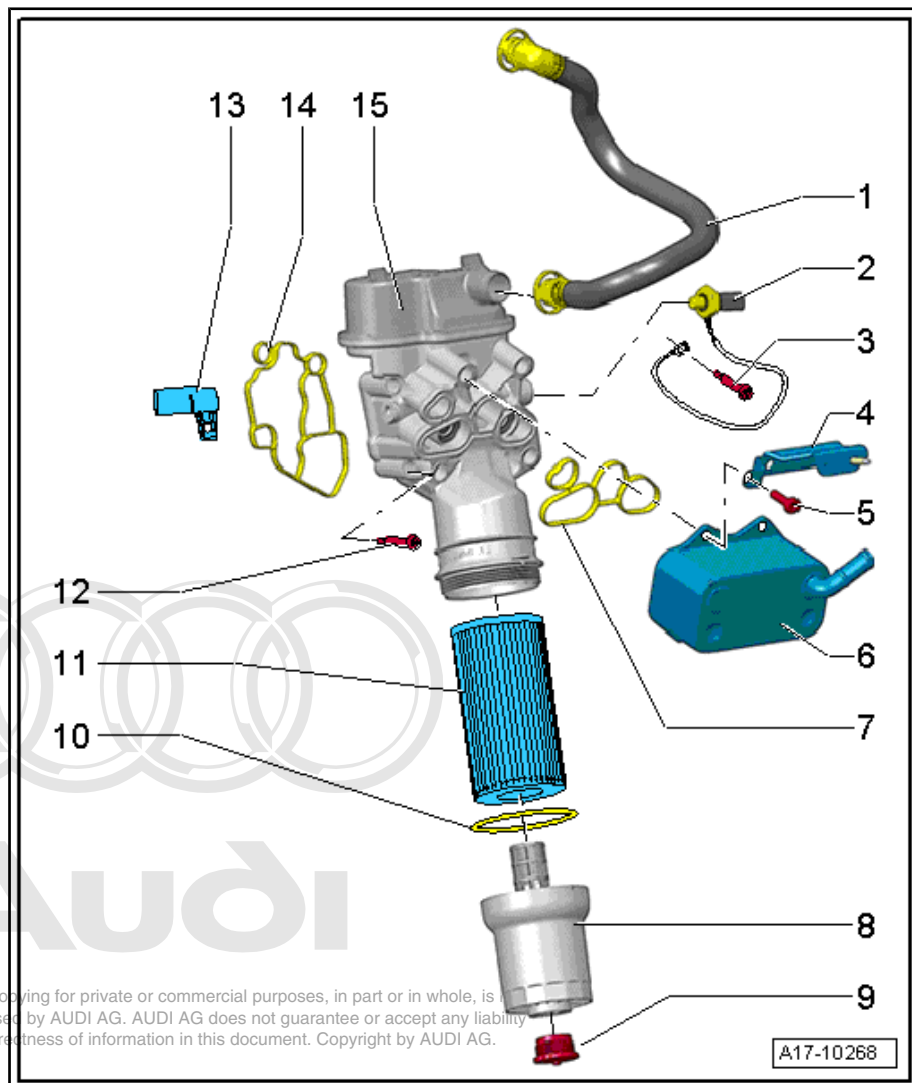

14 - Gasket

- Renew

15 - Oil filter bracket

- Removing and installing => [page 137](#)

Installation position of baffle plate

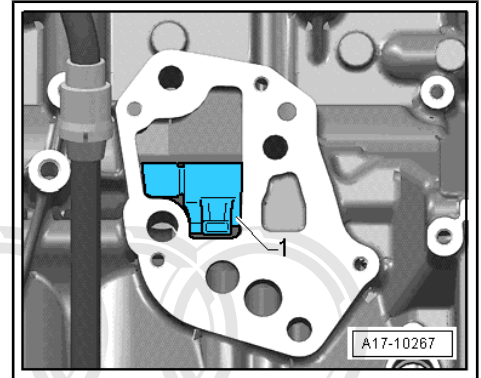

Installation position of seal

- Note position of service tab on seal -arrow-.
- Flat side of seal must face outwards.

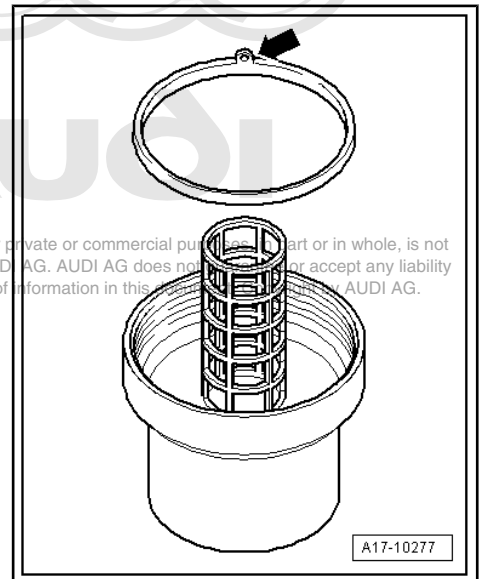

Protected by copyright. Copying for private or commercial purposes, in part or in whole, is not permitted unless authorised by AUDI AG. AUDI AG does not accept any liability with respect to the correctness of information in this manual. © AUDI AG.

2.2 Draining oil filter housing



Note

A valve in the oil filter housing will be opened when the oil drain adapter -T40057- is screwed in. The valve will be closed again as soon as the oil drain adapter -T40057- is unscrewed.

Special tools and workshop equipment required



- ◆ Oil drain adapter -T40057-

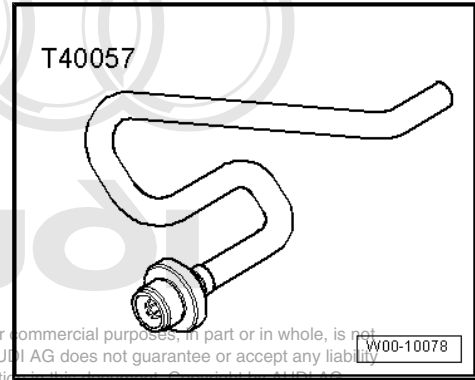

Protected by copyright. Copying for private or commercial purposes, in part or in whole, is not permitted unless authorised by AUDI AG. AUDI AG does not guarantee or accept any liability with respect to the correctness of information in this document. Copyright by AUDI AG.

- Unscrew dust cap from oil filter housing -arrow-.

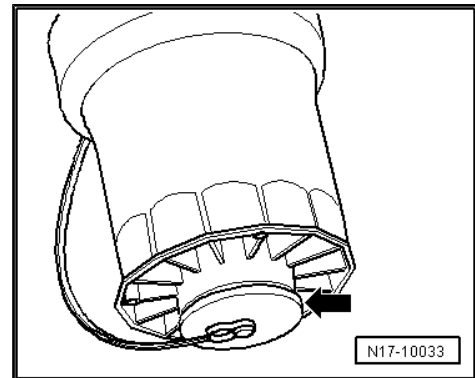

- Direct hose of oil drain adapter -T40057- into a drip tray and screw oil drain adapter -T40057- into oil filter housing.
- Drain engine oil

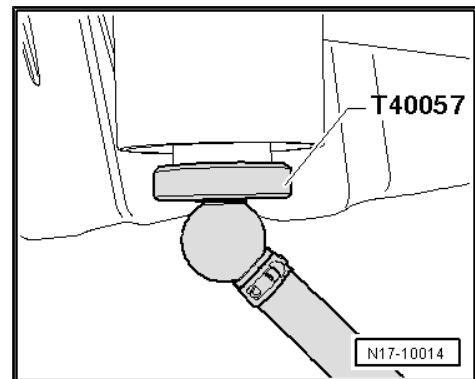

2.3 Removing and installing oil cooler

Special tools and workshop equipment required

- ◆ Drip tray for workshop hoist -VAS 6208-

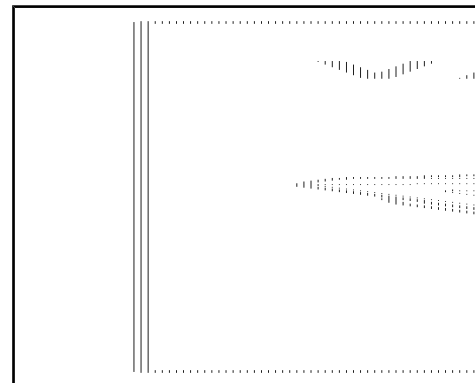

- ◆ Hose clip pliers -V.A.G 1921-

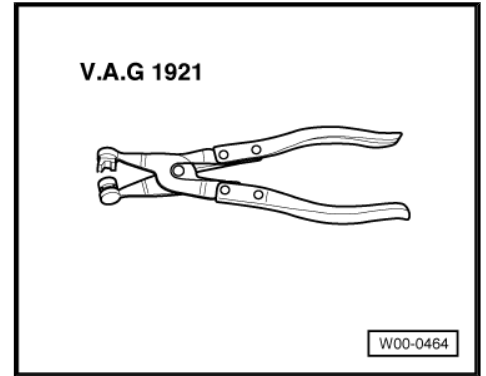

Removing



WARNING

Hot steam/hot coolant may escape when opening expansion tank. Cover cap with cloth and open carefully.

- Open filler cap on coolant expansion tank
- Unplug electrical connector at air mass meter -G70- -3-.
- Open clamps -1 and 2- and disconnect air intake hose from air mass meter.
- Detach air intake connection at lock carrier -4-.
- Pull off engine cover panel.

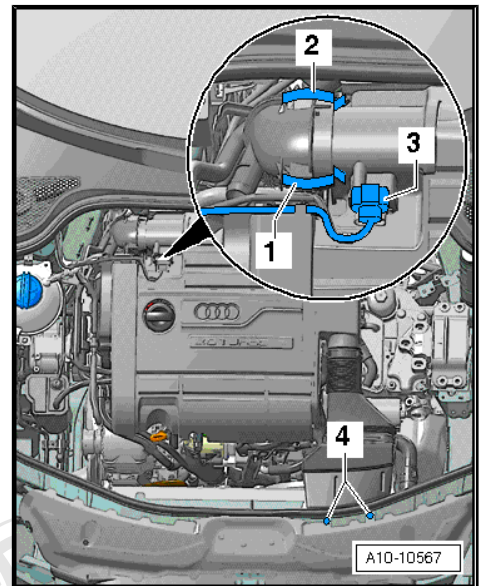

- Remove centre noise insulation -fasteners 1 ... 4-.

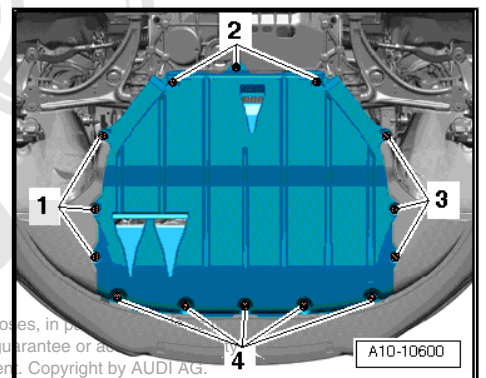

Protected by copyright. Copying for private or commercial purposes, in part or in full, is not permitted unless authorised by AUDI AG. AUDI AG does not guarantee or accept any liability with respect to the correctness of information in this document. Copyright by AUDI AG.



- Remove noise insulation frame -arrow-.
- Drain off coolant => [page 147](#)
- Remove intake manifold and fuel rail => Motronic direct injection and ignition system (4-cylinder); Repair group 24; Servicing injection system

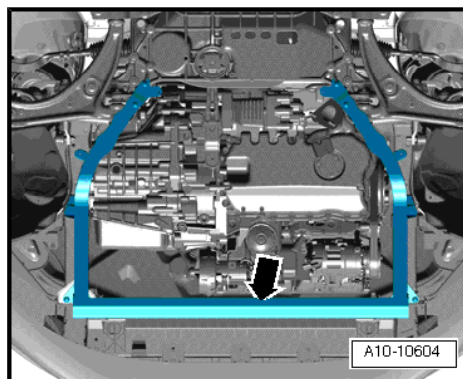

- Unbolt bracket for connectors -arrows- from coolant pipe.

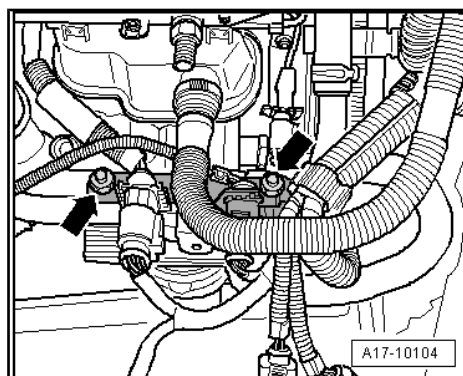

- Disconnect coolant hose -1-.
- Remove bolt -2-.

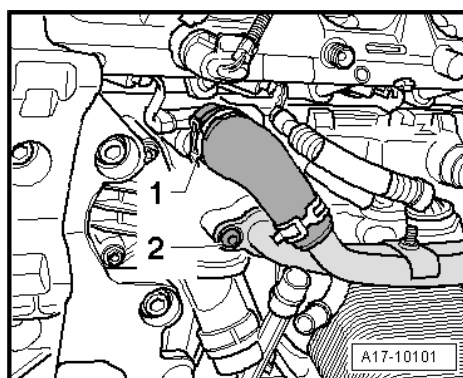

- Detach coolant hoses -arrows- from coolant pipe.
- Unscrew bolt -1- and detach coolant pipe.

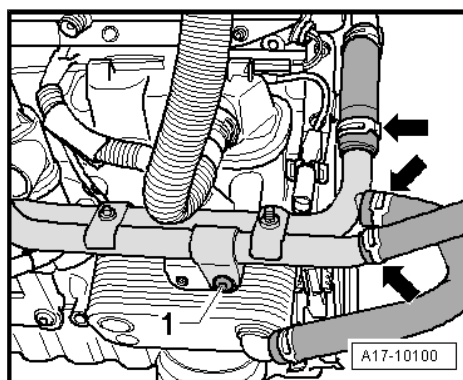

Protected by copyright. Copying for private or commercial purposes, in part or in whole, is not permitted unless authorised by AUDI AG. AUDI AG does not guarantee or accept any liability with respect to the correctness of information in this document. Copyright by AUDI AG.

- Remove oil cooler -arrows-.

Installing

Installation is carried out in the reverse order; note the following:

- Tightening torques ⇒ [page 132](#)
- Tightening torques ⇒ [page 144](#)

Note

- ◆ *Renew gaskets and seals.*
 - ◆ *Secure all hose connections with the correct type of hose clips (same as original equipment) ⇒ Parts catalogue.*
- Fill up with coolant ⇒ [page 147](#) .

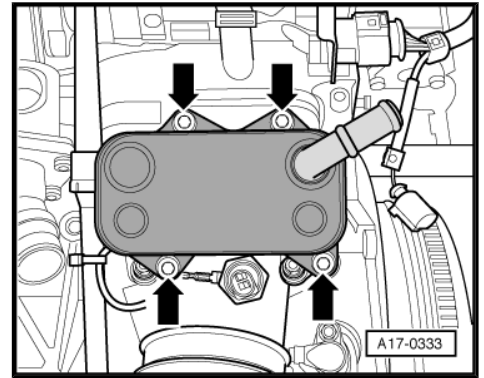

2.4 Removing and installing oil filter bracket

Special tools and workshop equipment required

- ◆ Drip tray for workshop hoist -VAS 6208-

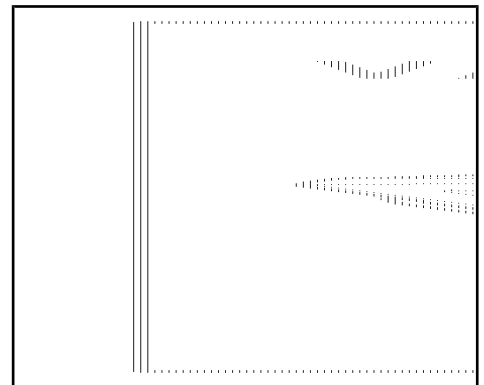

- ◆ Hose clip pliers -V.A.G 1921-

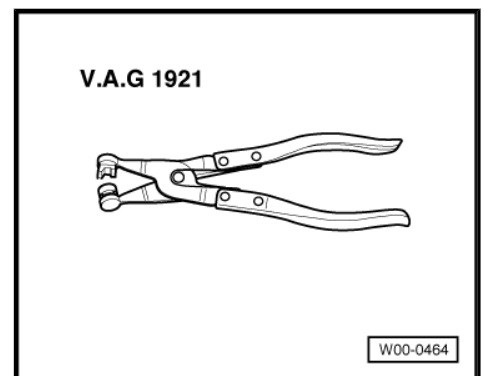
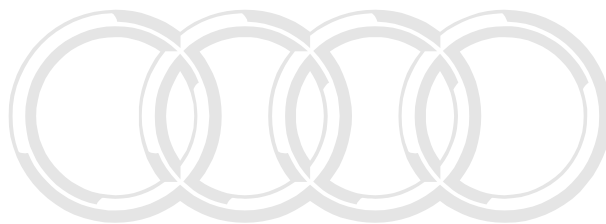

- ◆ Locking pin -T10060A-

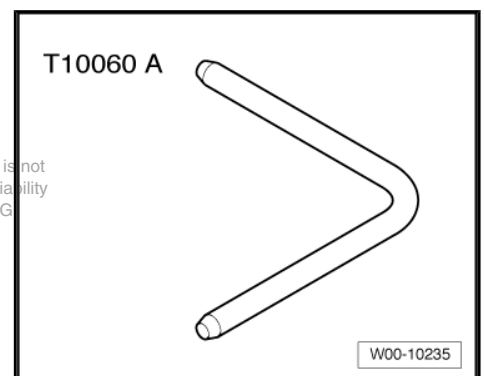

Protected by copyright. Copying for private or commercial purposes, in part or in whole, is not permitted unless authorised by AUDI AG. AUDI AG does not guarantee or accept any liability with respect to the correctness of information in this document. Copyright by AUDI AG



Removing



WARNING

Hot steam/hot coolant may escape when opening expansion tank. Cover cap with cloth and open carefully.

- Open filler cap on coolant expansion tank

Removing

- Unplug electrical connector at air mass meter -G70- -3-.
- Open clamps -1 and 2- and disconnect air intake hose from air mass meter.
- Detach air intake connection at lock carrier -4-.
- Pull off engine cover panel.

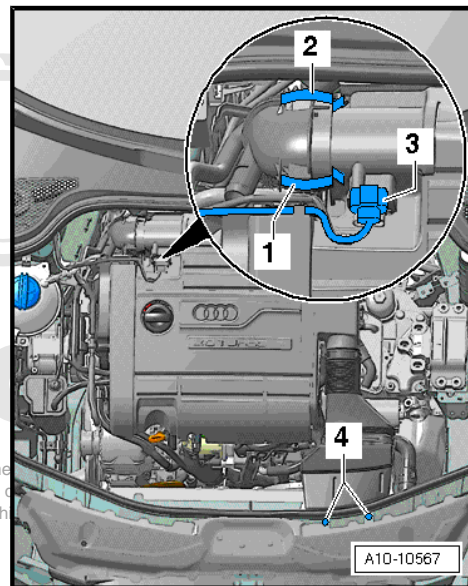

Protected by copyright. Copying for private or commercial use is not permitted unless authorised by AUDI AG. AUDI AG does not accept any responsibility with respect to the correctness of information in this document.

- Remove centre noise insulation -fasteners 1 ... 4-.

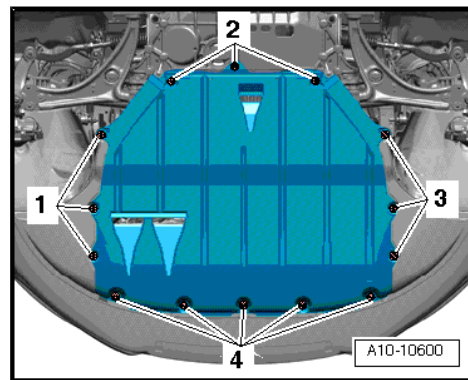

- Remove noise insulation frame -arrow-.
- Drain off coolant => [page 147](#)

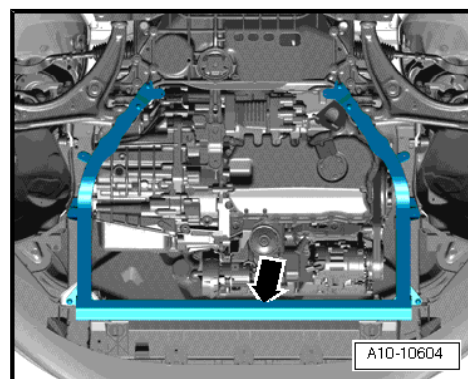

- To slacken poly V-belt, turn tensioner in -direction of arrow-.

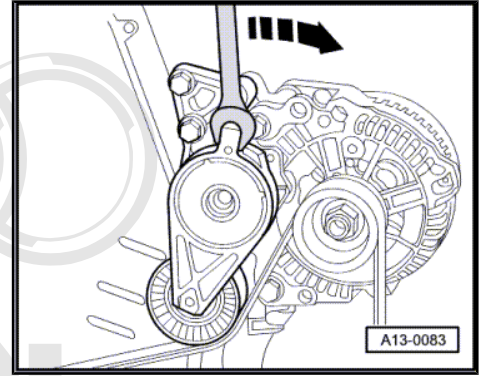

- Lock tensioner in position with locking pin -T10060A- .
- Take off poly V-belt.

Protected by copyright. Copying for private or commercial purposes, in part or in whole, is not permitted unless authorised by AUDI AG. AUDI AG does not guarantee or accept any liability with respect to the correctness of information in this document.

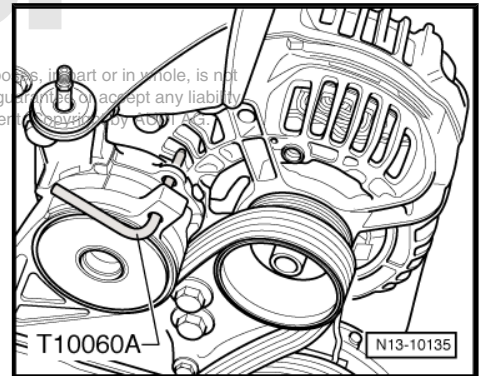

- Remove tensioner for poly V-belt -arrows-.
- Remove alternator => Electrical system; Repair group 27 .
- Remove intake manifold and fuel rail => Motronic direct injection and ignition system (4-cylinder); Repair group 24; Servicing injection system

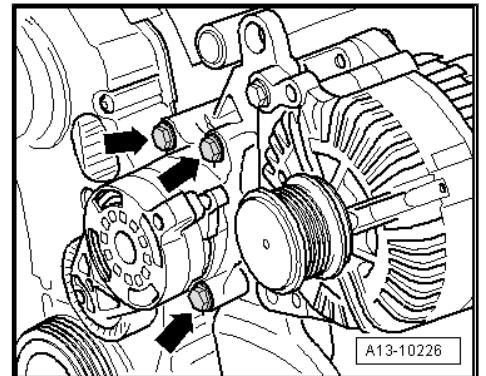

- Unbolt bracket for connectors -arrows- from coolant pipe.

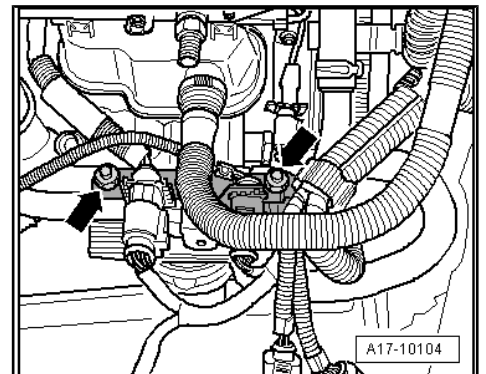



- Disconnect coolant hose -1-.
- Remove bolt -2-.

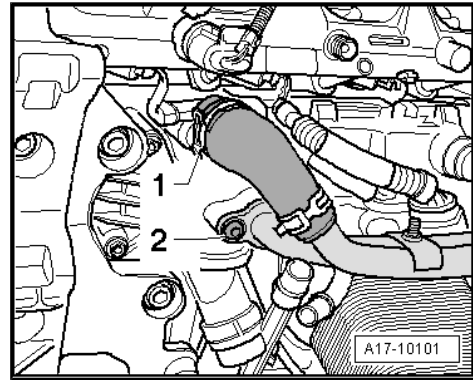

- Detach coolant hoses -arrows- from coolant pipe.
- Unscrew bolt -1- and detach coolant pipe.

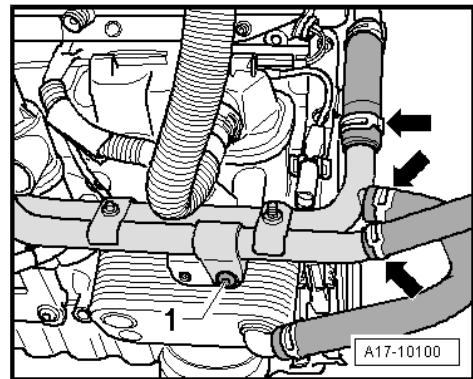

- Remove oil cooler -arrows-.

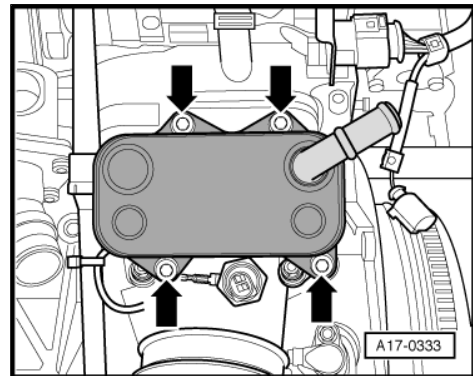

- Detach pipe -1- for crankcase breather system.
- Unscrew earth cable -2- for oil pressure switch.
- Unscrew bolts -arrows- and remove oil filter bracket.

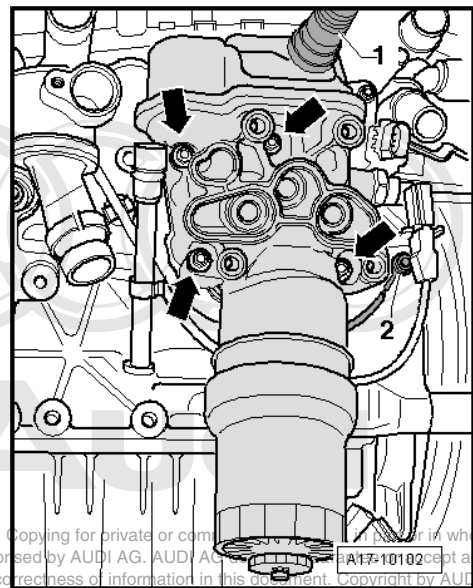

Installing

Installation is carried out in the reverse order; note the following:

- Tightening torques ⇒ [page 132](#)
- Tightening torques ⇒ [page 144](#)



Note

- ◆ *Renew gaskets and seals.*
- ◆ *Secure all hose connections with the correct type of hose clips (same as original equipment) ⇒ Parts catalogue.*

- Install baffle plate ⇒ [Item 13 \(page 132\)](#)
- Fill up with coolant ⇒ [page 147](#) .

Protected by copyright. Copying for private or commercial use without permission in whole, is not permitted unless authorised by AUDI AG. AUDI AG does not accept any liability with respect to the correctness of information in this document. Copyright by AUDI AG.

2.5 Checking oil pressure and oil pressure switch

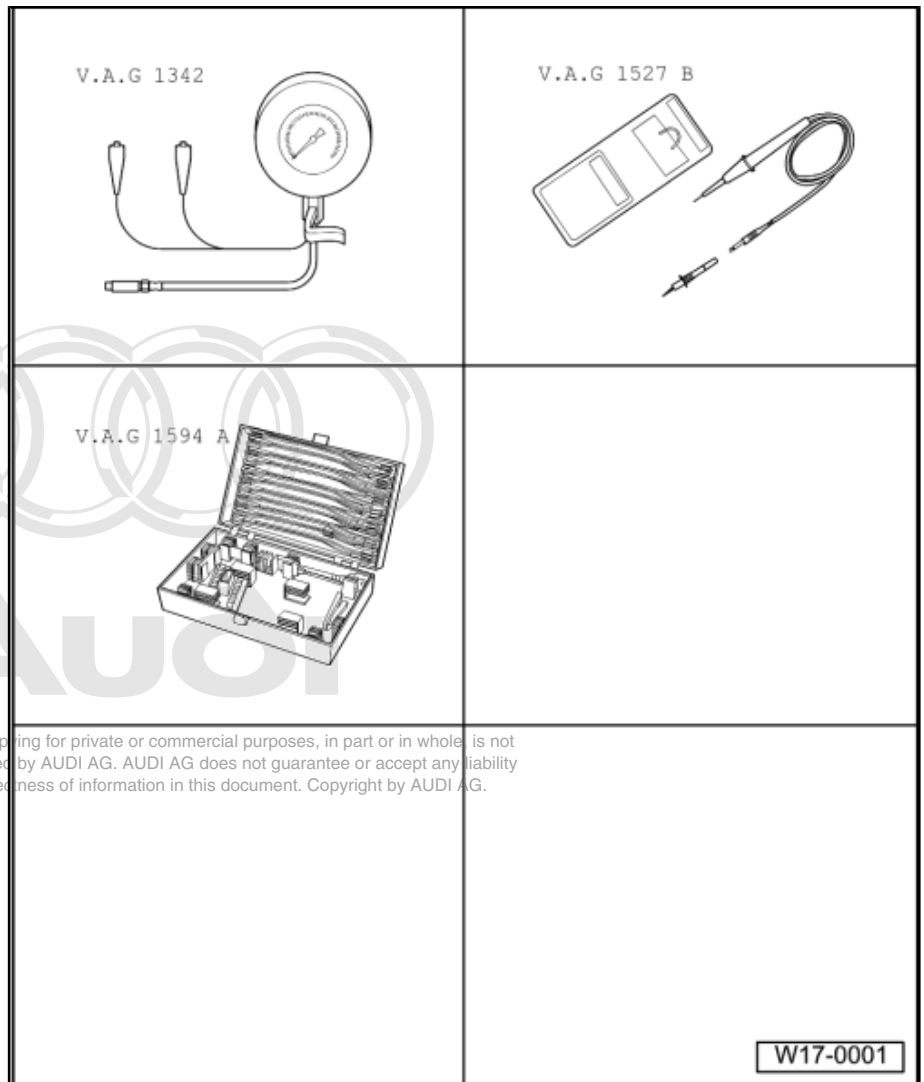

Special tools and workshop equipment required

- ◆ Oil pressure tester -V.A.G 1342-
- ◆ Voltage tester -V.A.G 1527 B-
- ◆ Auxiliary measuring set -V.A.G 1594 C-

Test requirements

- Engine oil level OK, checking ⇒ Maintenance ; Booklet 810
- Oil pressure warning lamp must light up for approx. 3 seconds when ignition is switched on.
- In vehicles with auto-check system, the "OK" display must light up (select symbol).
- Engine oil temperature at least 80°C (radiator fan must have run once)

**Note**

Functional check and servicing the visual and acoustic oil pressure warning: Current flow diagrams, ⇒ Vehicle diagnosis, testing and information system VAS 5051; "Function and component selection".

Test sequence

- Tightening torques ⇒ [page 132](#)
- Remove the oil pressure switch -F1- -A- and screw it onto tester.
- Screw tester into oil filter bracket in place of the oil pressure switch.
- Connect brown wire of tester to earth (-).
- Connect voltage tester -V.A.G 1527 B- with adapter leads from auxiliary measuring set -V.A.G 1594 C- to battery positive (+) and oil pressure switch -F1- -B-. LED must not light up.
- If the LED lights up, renew 1.4 bar oil pressure switch.

If the LED does not light up:

- Start engine and run at increased speed: at 1.2 ... 1.6 bar pressure the LED should light up, otherwise renew oil pressure switch -F1- .
- Increase engine speed further. At 2,000 rpm and an oil temperature of 80 °C the oil pressure should be between 2.7 ... 4.5 bar.

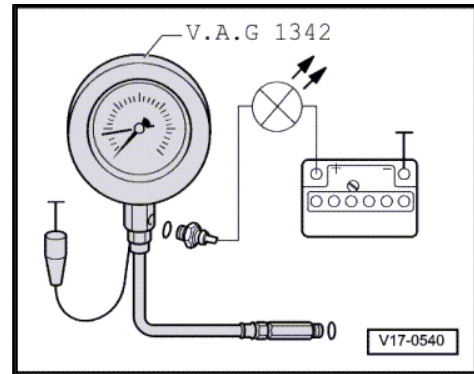

Protected by copyright. Copying for private or commercial purposes, in part or in whole, is not permitted unless authorised by AUDI AG. AUDI AG does not guarantee or accept any liability with respect to the correctness of information in this document. Copyright by AUDI AG.

19 – Cooling

1 Removing and installing parts of cooling system



WARNING

Hot steam/hot coolant may escape when opening expansion tank. Cover cap with cloth and open carefully.



Note

- ◆ *The cooling system is under pressure when the engine is hot. If necessary, relieve pressure before commencing repair work.*
- ◆ *Secure all hose connections with the correct type of hose clips (same as original equipment) ⇒ Parts catalogue.*
- ◆ *Hose clip pliers -V.A.G 1921- or spring-type clip pliers -VAS 5024 A- are recommended for use in installing spring-type clips.*
- ◆ *Renew gaskets and seals.*
- ◆ *The arrow markings on coolant pipes and on ends of hoses must align.*

1.1 Cooling system components (on engine) - exploded view

- 1 - Bolt
 - 40 Nm
- 2 - Bolt
 - 30 Nm
- 3 - Coolant pipe
- 4 - Connecting hose
- 5 - O-ring
 - Renew
- 6 - Connection
- 7 - Bolt
 - 10 Nm
- 8 - Retaining clip
- 9 - O-ring
 - Renew
- 10 - Coolant temperature sender -G62-
 -
- 11 - Connecting hose
- 12 - Connecting piece
- 13 - Connecting hose
- 14 - Connecting hose
- 15 - Connecting hose
- 16 - Coolant pipe
- 17 - Bolt
 - 5 Nm
- 18 - Connecting hose
- 19 - Coolant pipe
- 20 - Bolt
 - 5 Nm
- 21 - Coolant distributor housing
 - With thermostat
 - Starts to open at 87°C
- 22 - Bolt
 - 15 Nm
- 23 - Coolant pump
 - Removing and installing ⇒ [page 155](#)
- 24 - Bolt
 - 15 Nm

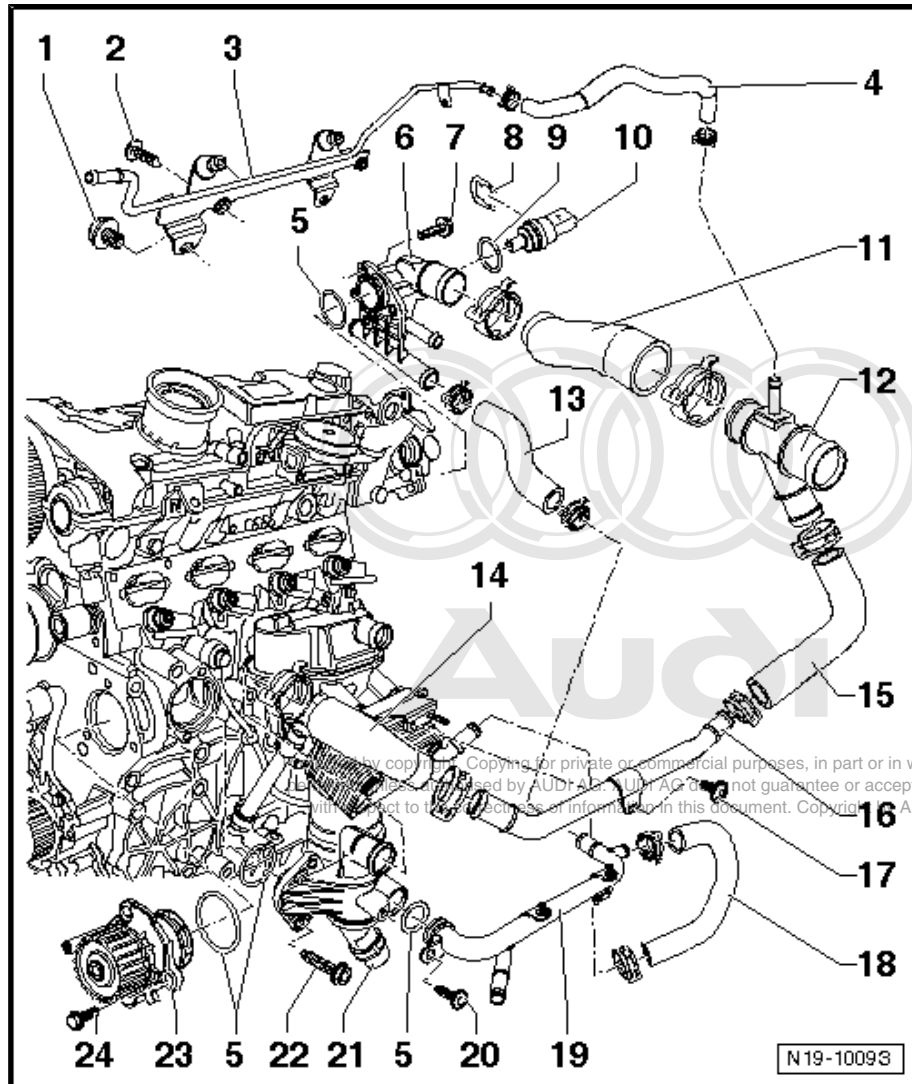

Copying for private or commercial purposes, in part or in whole, is not permitted. Audi AG does not guarantee or accept any liability with respect to the correctness of information in this document. Copyright © Audi AG.

1.2 Continued coolant circulation pump -V51- - exploded view

- 1 - Nut
 3 Nm
- 2 - Coolant pipe
- 3 - Spring-type hose clip
- 4 - Coolant pipe
 To turbocharger
- 5 - Bolt
 5 Nm
- 6 - Spring-type hose clip
- 7 - Coolant hose
- 8 - Bracket
- 9 - Coolant hose
 Going to radiator
- 10 - Spring-type hose clip
- 11 - Continued coolant circulation pump -V51-
- 12 - Bolt
 5 Nm
- 13 - Spring-type hose clip
- 14 - Nut
 5 Nm

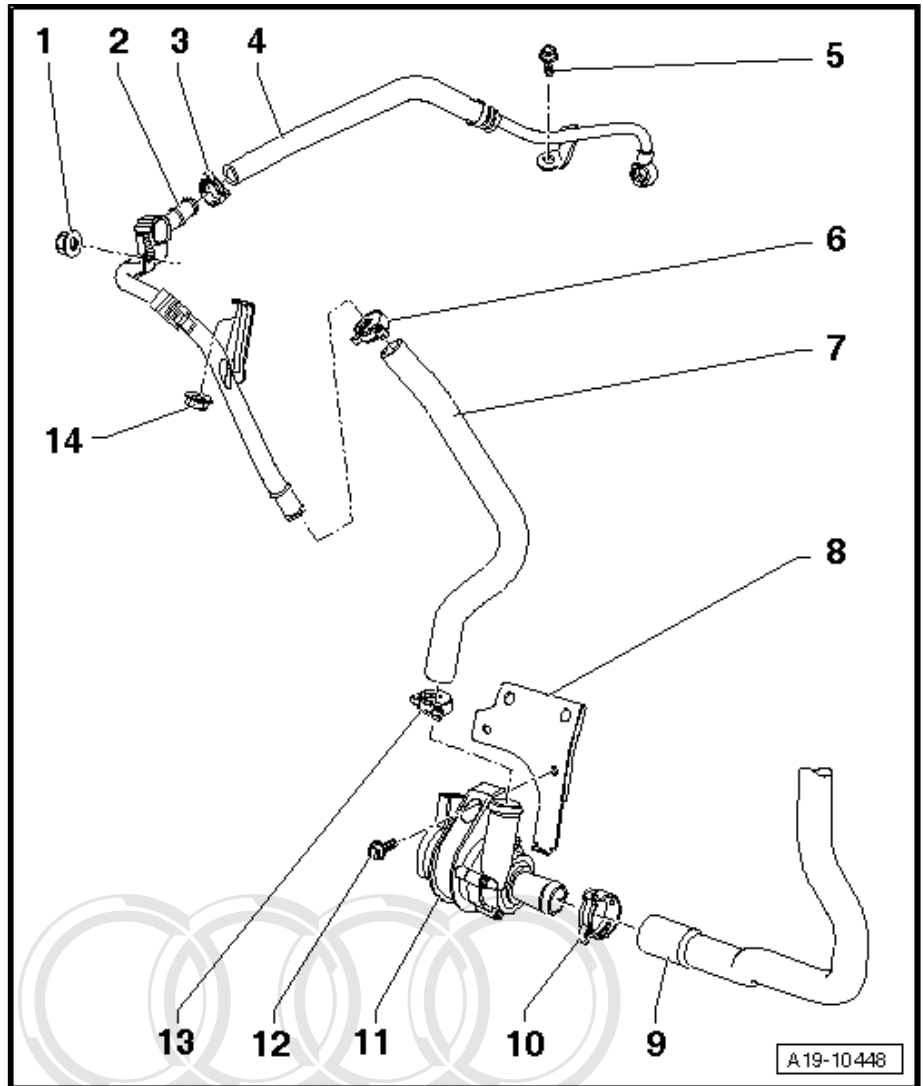

Audi

Protected by copyright. Copying for private or commercial purposes, in part or in whole, is not permitted unless authorised by AUDI AG. AUDI AG does not guarantee or accept any liability with respect to the correctness of information in this document. Copyright by AUDI AG.

1.3 Diagram of coolant hose connections

1 - Radiator

- Removing and installing ⇒ [page 158](#)
- If renewed, refill system with fresh coolant

2 - Continued coolant circulation pump -V51-

3 - Map-controlled engine cooling thermostat -F265-

- Removing and installing ⇒ [page 155](#)

4 - Coolant pump

- Removing and installing ⇒ [page 155](#)

5 - Cylinder head/cylinder block

- If renewed, refill system with fresh coolant

6 - Turbocharger

- Removing and installing ⇒ [page 164](#)

7 - Expansion tank

- With filler cap
- Testing pressure relief valve in filler cap ⇒ [page 151](#)

8 - Heat exchanger (for heating system)

- If renewed, refill system with fresh coolant

9 - Coolant connecting pipe

10 - Engine oil cooler

11 - Intake manifold

- Removing and installing ⇒ Rep. Gr. 24

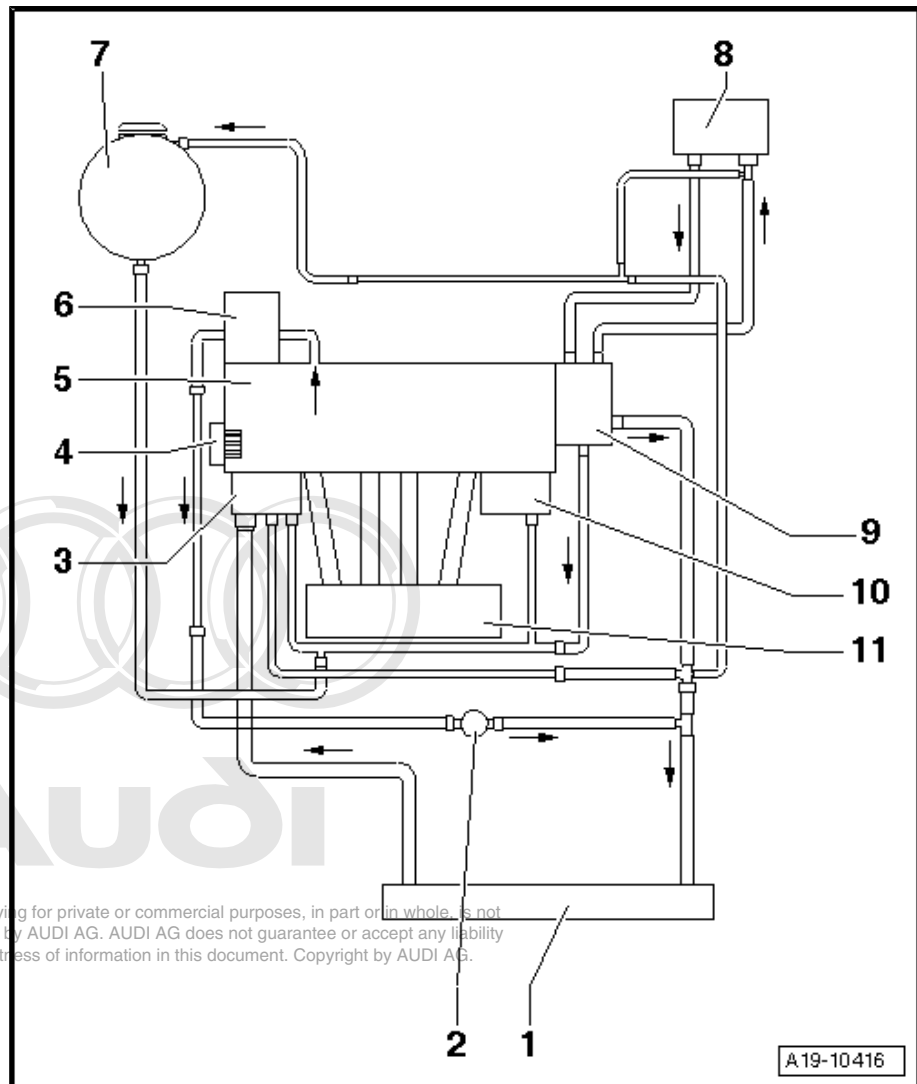

1.4 Draining and filling cooling system

Special tools and workshop equipment required

- ◆ Adapter for cooling system tester -V.A.G 1274/8-
- ◆ Drip tray for workshop hoist -VAS 6208-
- ◆ Hose clip pliers - V.A.G 1921-
- ◆ Cooling system charge unit -VAS 6096-
- ◆ Refractometer -T10007-

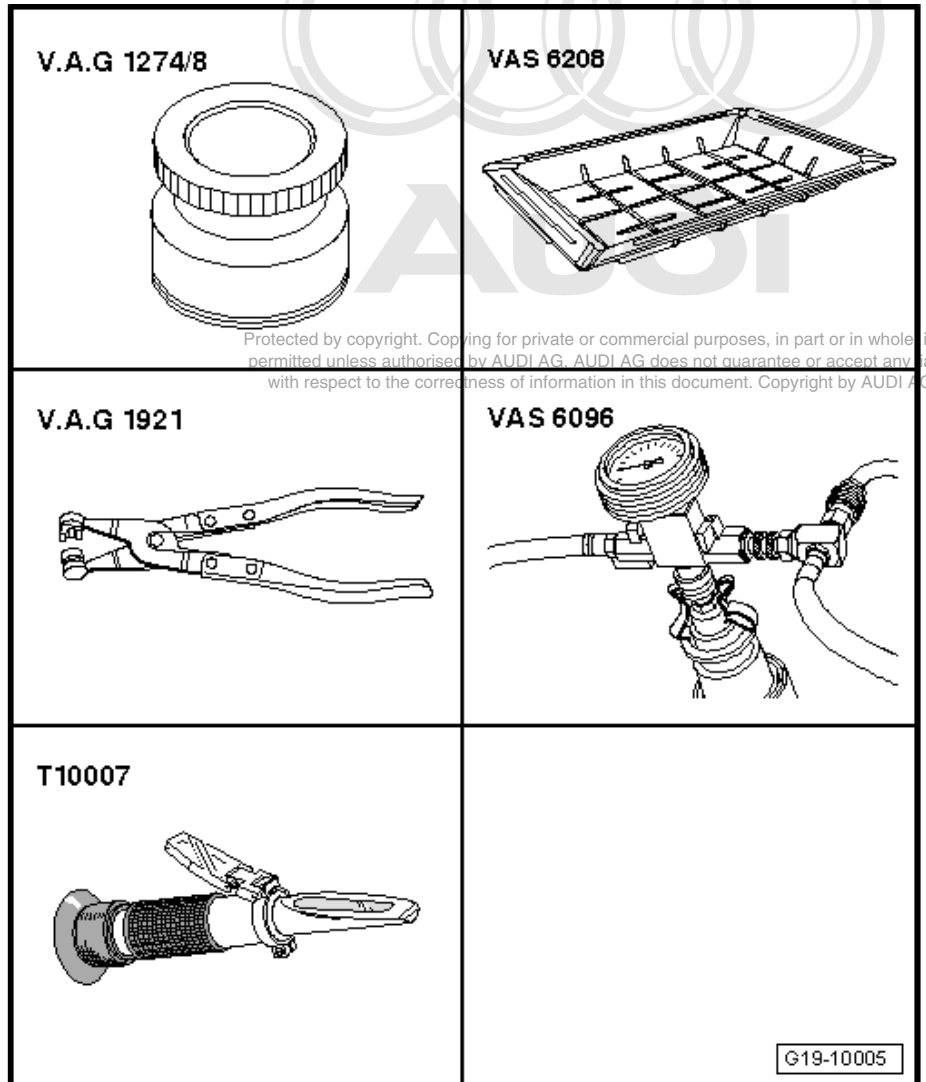

Draining



Collect drained coolant in a clean container for re-use or disposal.



WARNING

Hot steam/hot coolant may escape when opening expansion tank. Cover cap with cloth and open carefully.

- Open filler cap on coolant expansion tank



- Remove centre noise insulation -fasteners 1 ... 4-.

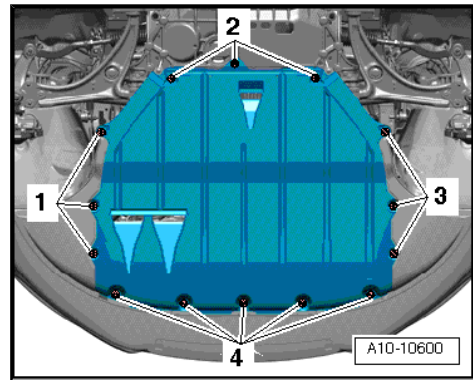

- Remove noise insulation frame -arrow-.
- Place drip tray for workshop hoist -VAS 6208- beneath engine.

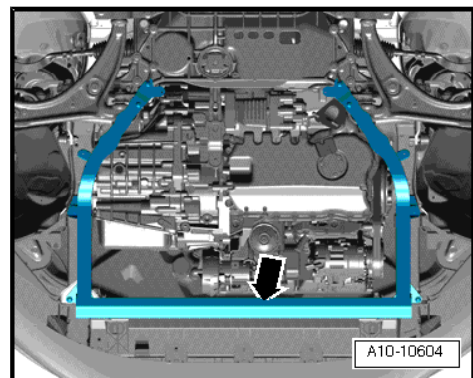

Protected by copyright. Copying for private or commercial purposes, in part or in whole, is not permitted unless authorised by AUDI AG. AUDI AG does not guarantee or accept any liability with respect to the correctness of information in this document. Copyright by AUDI AG.

- To drain off coolant, detach bottom coolant hose -arrow-.

Filling

Note

- ◆ *The cooling system is filled all year round with a mixture of water and radiator antifreeze/anti-corrosion agent.*
- ◆ *Only use coolant additive G 12+ in accordance with TL - VW 774 F- . Other coolant additives could seriously impair in particular the anticorrosion properties. The resulting damage could lead to loss of coolant and consequently to serious engine damage.*
- ◆ *Coolant additive G12+ can be mixed with additives G11 and G12.*
- ◆ *G 12+ and coolant additives marked "meeting specification TL -VW 774- F" prevent frost and corrosion damage as well as scaling. Such additives also raise the boiling point of the coolant. For these reasons the cooling system must be filled all year round with the correct antifreeze and anticorrosion additive.*
- ◆ *Because of its high boiling point, the coolant improves engine reliability under heavy loads, particularly in countries with tropical climates.*
- ◆ *Frost protection is required down to about -25 °C (in countries with arctic climate: down to about -35 °C).*
- ◆ *The coolant concentration must not be reduced by adding water even in warmer seasons and in warmer countries. The antifreeze concentration must be at least 40 %.*
- ◆ *If greater frost protection is required in very cold climates, the amount of G 12+ can be increased, but only up to 60 % (this gives frost protection to about -40 °C), as otherwise frost protection is reduced again, as is cooling effectiveness.*
- ◆ *Use only clean tap water for mixing coolant.*
- ◆ *If radiator, heat exchanger, cylinder head, cylinder head gasket or cylinder block are renewed, do not reuse old coolant.*
- ◆ *Contaminated or dirty coolant must not be used again.*
- ◆ *For checking anti-freeze protection in cooling system, use refractometer -T10007- for coolant additive G12+.*

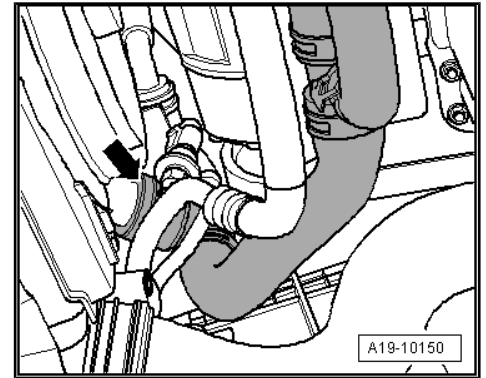

- Connect bottom coolant hose to radiator -arrow-

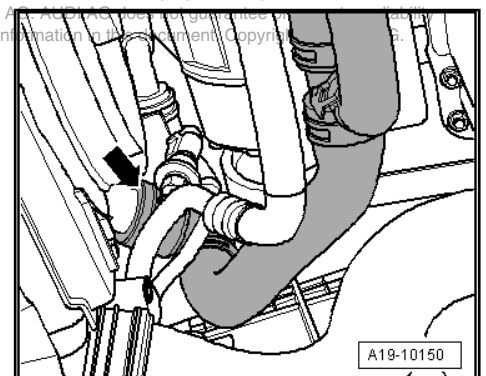

Protected by copyright. Copying for private or commercial purposes, in part or in whole, is not permitted unless authorised by AUDI AG. AUDI AG does not guarantee the accuracy of the information in this document. Copyright © Audi AG 2006.



- Fill reservoir of cooling system charge unit -VAS 6096- with at least 8 litres of premixed coolant (based on recommended ratio):
 - ◆ G12+ (40%) and water (60%) for frost protection to -25 °C
 - ◆ G12+ (50%) and water (50%) for frost protection to -35 °C
 - ◆ G12+ (60%) and water (40%) for frost protection to -40 °C
- Screw adapter for cooling system tester -V.A.G 1274/8- onto coolant expansion tank.
- Fit cooling system charge unit -VAS 6096- onto adapter for cooling system tester -V.A.G 1274/8- .
- Run vent hose -1- into a small container -2-. (The vented air draws along a small amount of coolant, which should be collected.)
- Close the two valves -A- and -B- (levers at right angles to direction of flow).
- Connect hose -3- to compressed air.
- Pressure: 6 ... 10 bar

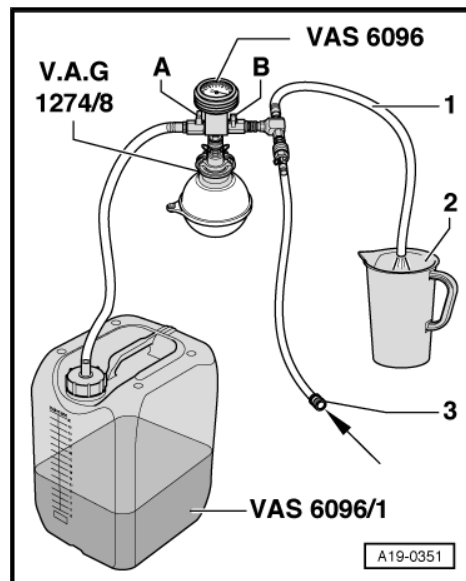

- Open valve -B- (lever in direction of flow).

The suction jet pump generates a partial vacuum in the cooling system.

- The needle on the gauge should move into the green zone.
- Additionally open valve -A- briefly (lever in direction of flow) so that the hose of cooling system charge unit -VAS 6096- is filled with coolant.
- Close valve -A- again.
- Leave valve -B- open for another 2 minutes.

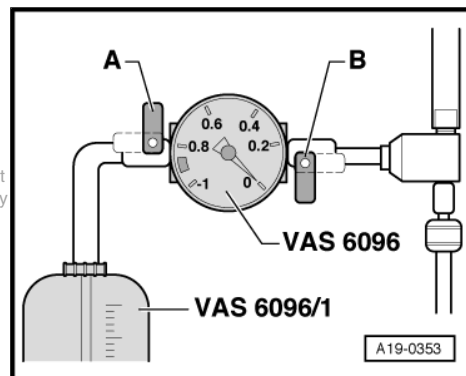

The suction jet pump will continue generating a vacuum in the cooling system.

- The needle on the gauge should remain in the green zone.
- Close valve -B-.
- The needle on the gauge should stop in the green zone. The vacuum level in the cooling system is then sufficient for subsequent filling.

If the needle does not reach the green area, repeat the process.

If the vacuum level drops, there is a leak in the cooling system.

- Detach compressed air hose.
- Open valve -A-.

The vacuum in the cooling system causes the coolant to be drawn out of the cooling system charge unit -VAS 6096- ; the cooling system is then filled.

- Check the coolant level and top up coolant as far as the max mark.
- Start engine, run for 2 minutes (maximum) at approx. 1500 rpm and top up coolant to overflow hole on expansion tank with engine running.
- Fit expansion tank cap.
- Run engine until radiator fan cuts in.

**WARNING**

Hot steam/hot coolant may escape when opening expansion tank. Cover cap with cloth and open carefully.

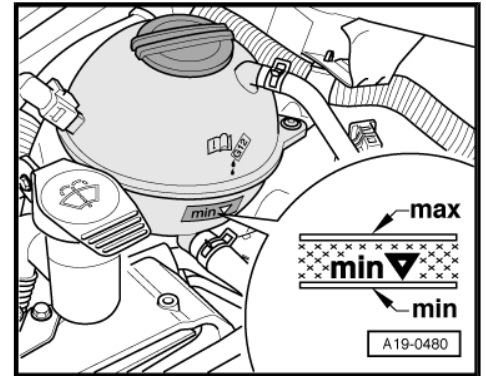

- Check coolant level and top up if necessary. When the engine is at normal operating temperature, the coolant level must be on the MAX mark; when the engine is cold, between the MIN and MAX marks.
- Switch off engine.

1.5 Checking cooling system for leaks

Special tools and workshop equipment required

- ◆ Cooling system tester - V.A.G 1274-
- ◆ Adapter for cooling system tester -V.A.G 1274/8-
- ◆ Adapter for cooling system tester -V.A.G 1274/9-

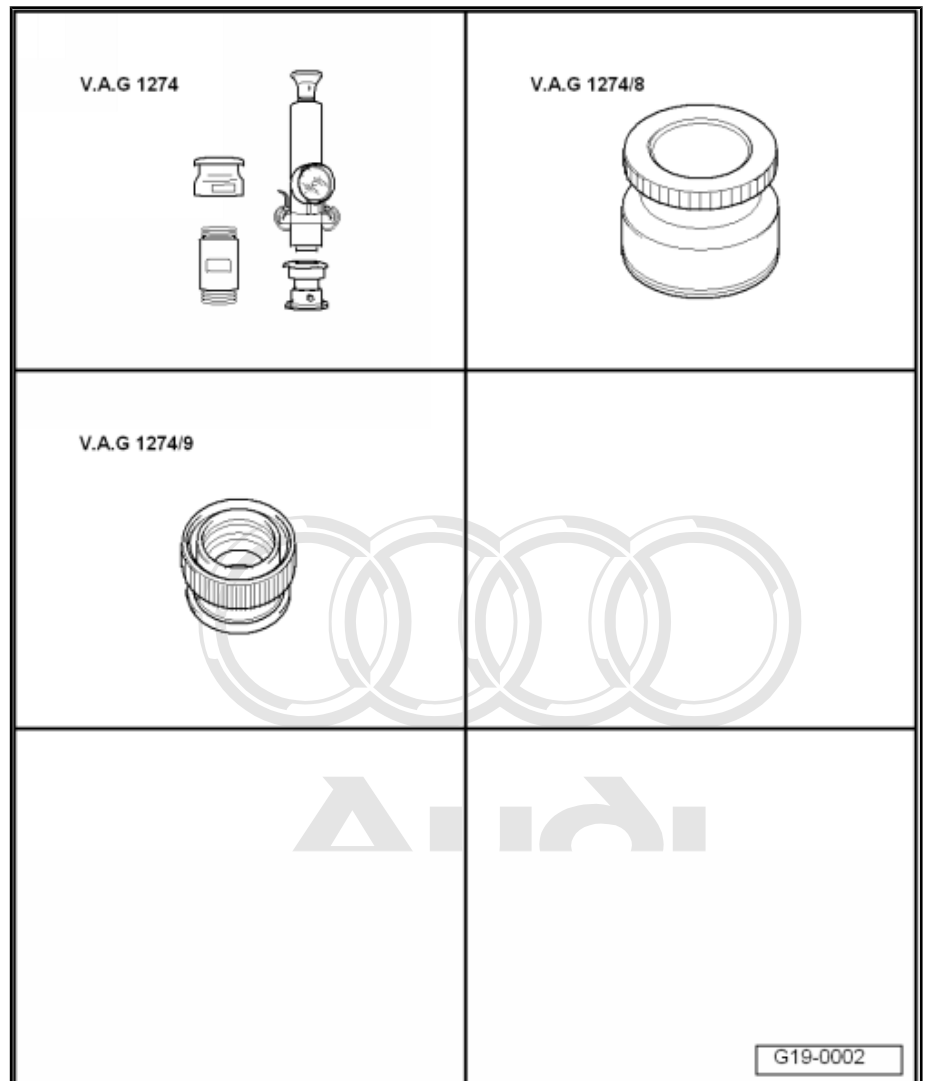



Test condition

- Engine must be warm.

Test sequence



WARNING

Hot steam/hot coolant may escape when opening expansion tank. Cover cap with cloth and open carefully.

- Open filler cap on coolant expansion tank
- Fit cooling system tester -V.A.G 1274- with adapter for cooling system tester -V.A.G 1274/8- on coolant expansion tank.
- Using hand pump on tester, build up a pressure of approx. 1.0 bar.
- If this pressure is not maintained, locate and rectify leaks.

Checking pressure relief valve in cap.

- Fit cooling system tester -V.A.G 1274- with adapter for cooling system tester -V.A.G 1274/9- on filler cap.
- Operate hand pump.
- ◆ The pressure relief valve should open at a pressure of 1.4 ... 1.6 bar.

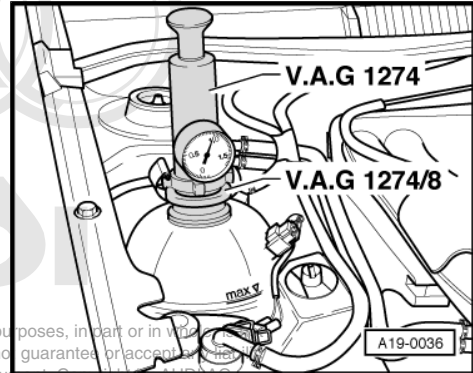

Protected by copyright. Copying for private or commercial purposes, in part or in whole, is not permitted unless authorised by AUDI AG. AUDI AG does not guarantee or accept any liability with respect to the correctness of information in this document. Copyright by AUDI AG.

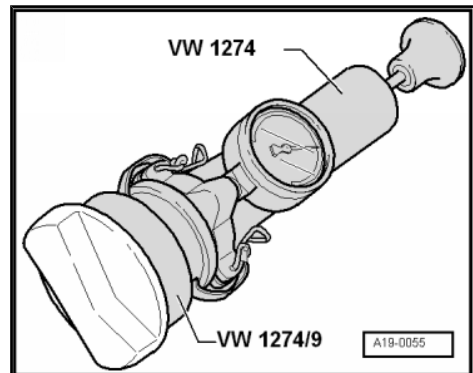

1.6 Removing and installing coolant pipes

Special tools and workshop equipment required

- ◆ Hose clip pliers -V.A.G 1921-

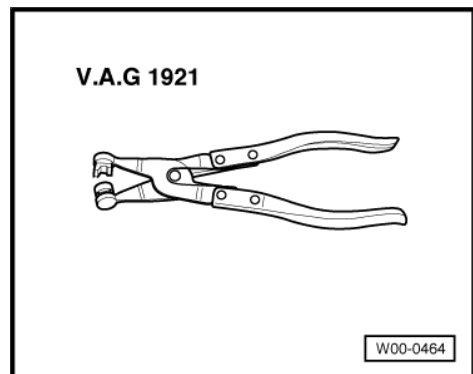

Removing

- Unplug electrical connector at air mass meter -G70- -3-.
- Open clamps -1 and 2- and disconnect air intake hose from air mass meter.
- Detach air intake connection at lock carrier -4-.
- Pull off engine cover panel.

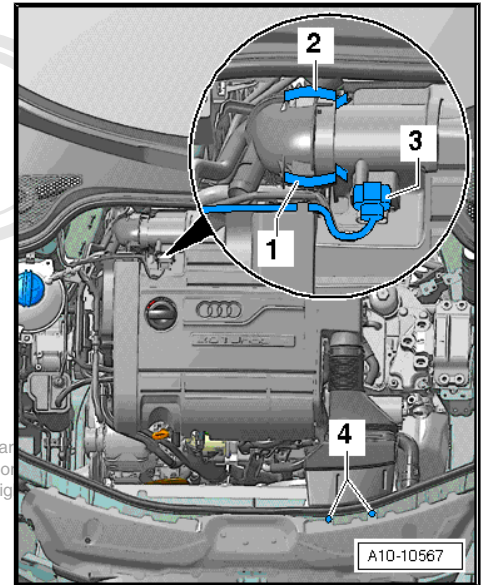

Protected by copyright. Copying for private or commercial purposes, in part permitted unless authorised by AUDI AG. AUDI AG does not guarantee or with respect to the correctness of information in this document. Copyright

- Remove pipe -A- and hose -B- -arrows-.

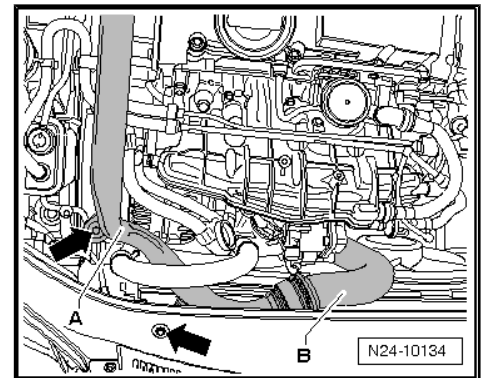

- Remove air pipe -1 and 2- for charge air cooler.

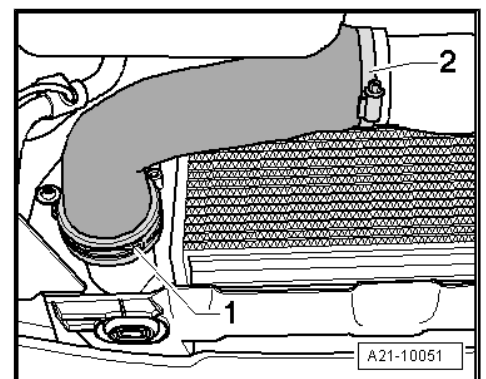

- Slacken clip -2-.
- Unplug electrical connector -4-.
- Remove nut -3- and bolt -1-.
- Take out intake connecting pipe downwards.
- Drain off coolant ⇒ [page 147](#) .

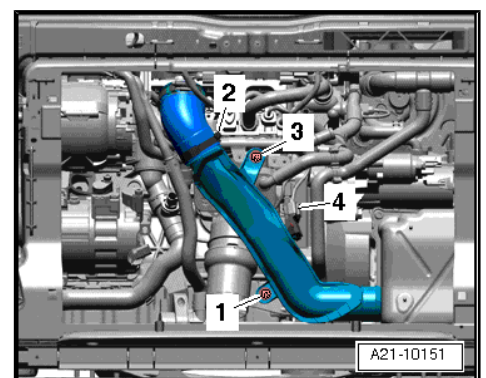

- Unplug electrical connectors -arrows-.

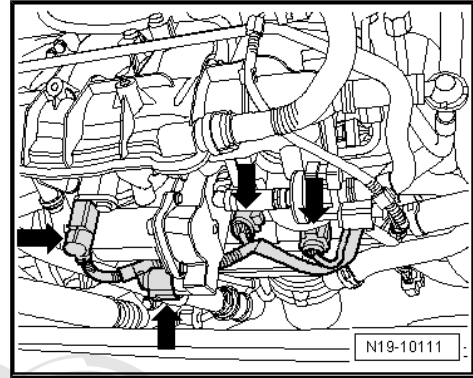

- Detach coolant hoses from coolant pipes -arrows-.

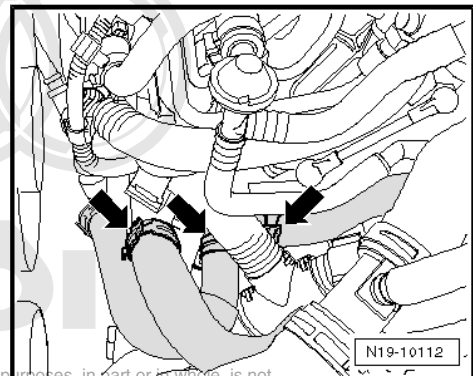

- Detach hose -A- and unscrew bolt -B-. Remove front coolant pipe.

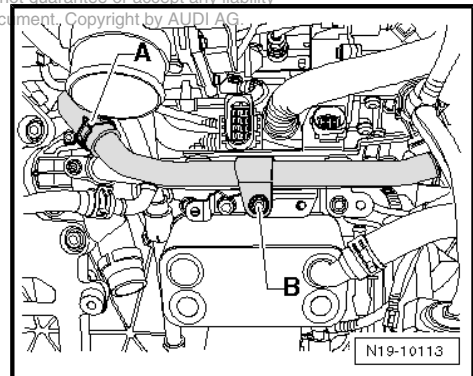

- Release connectors -A- from bracket, detach hose -B- and unscrew bolts -C-. Remove rear coolant pipe.

Installing

Installation is carried out in the reverse order; note the following:



Note

- ◆ *Renew gaskets and seals.*
 - ◆ *Secure all hose connections with the correct type of hose clips (same as original equipment) ⇒ Parts catalogue.*
- Fill up with coolant ⇒ [page 147](#) .

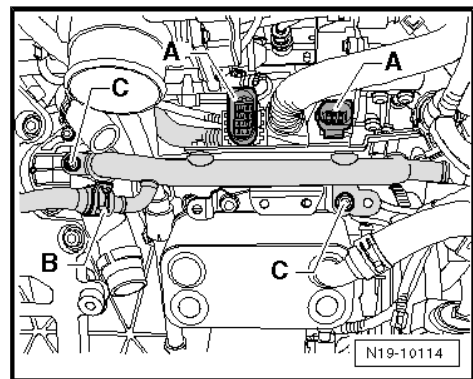

1.7 Removing and installing coolant distributor housing with map-controlled engine cooling thermostat -F265-

Removing

- Remove alternator ⇒ Electrical system; Rep. Gr. 27 ; Alternator .
- Remove coolant pipes ⇒ [page 152](#) .
- Detach coolant hose -2- from coolant distributor housing; to do so, pull out retaining clip -1-.

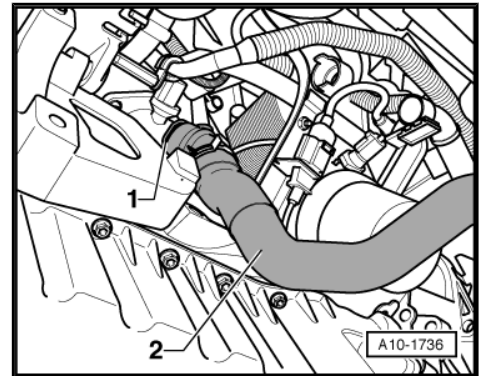

- Unscrew bolts -arrows- and remove coolant distributor housing with map-controlled engine cooling thermostat -F265- from engine.

Installing

Installation is carried out in the reverse order; note the following:

- Tightening torques ⇒ [page 144](#)

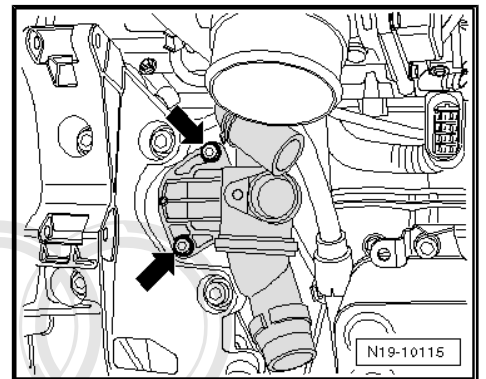

Note

- ◆ *Renew gaskets and seals.*
- ◆ *Secure all hose connections with the correct type of hose clips (same as original equipment) ⇒ Parts catalogue.*

- Clean sealing surface for O-ring.
- Renew O-ring and lubricate with coolant.
- Install alternator ⇒ Electrical system; Rep. Gr. 27 ; Alternator .
- Fill up with coolant ⇒ [page 147](#)

Protected by copyright. Copying for private or commercial purposes, in part or in whole, is not permitted unless authorised by AUDI AG. AUDI AG does not guarantee or accept any liability with respect to the correctness of information in this document. Copyright by AUDI AG.

1.8 Removing and installing coolant pump

Special tools and workshop equipment required



◆ Drip tray for workshop hoist -VAS 6208-

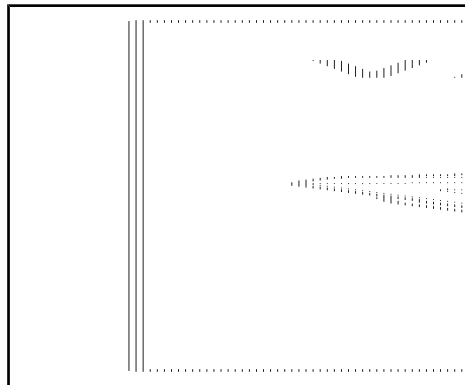

Removing



WARNING

Hot steam/hot coolant may escape when opening expansion tank. Cover cap with cloth and open carefully.

- Open filler cap on coolant expansion tank
- Unplug electrical connector at air mass meter -G70- -3-.
- Open clamps -1 and 2- and disconnect air intake hose from air mass meter.
- Detach air intake connection at lock carrier -4-.
- Pull off engine cover panel.

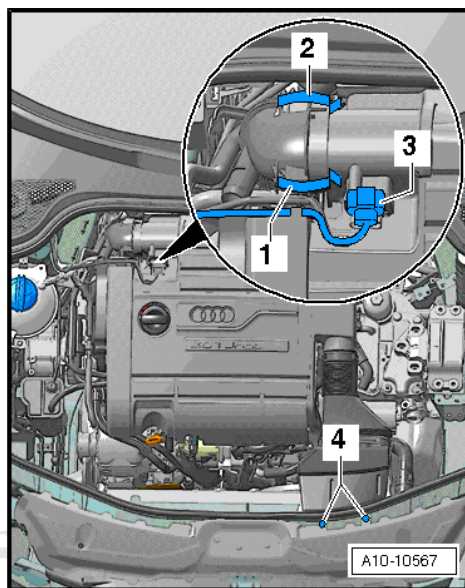

- Remove centre noise insulation -fasteners 1 ... 4-.

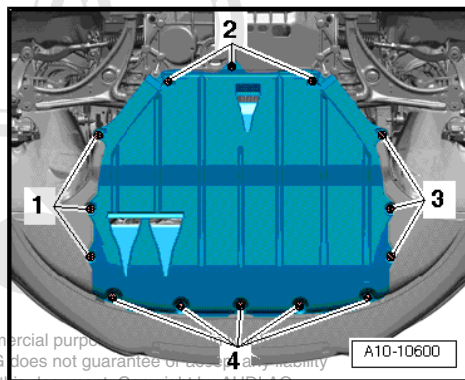

Protected by copyright. Copying for private or commercial purposes is not permitted unless authorised by AUDI AG. AUDI AG does not guarantee or accept any liability with respect to the correctness of information in this document. Copyright by AUDI AG.

- Remove right noise insulation -arrows-.

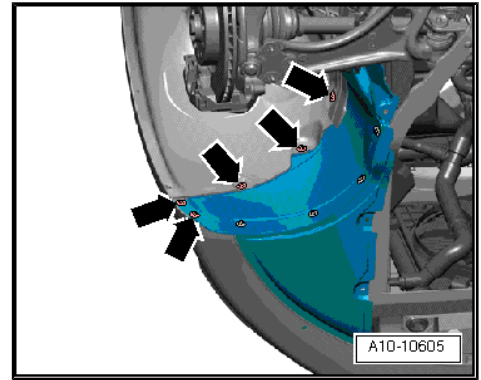

- Remove noise insulation frame -arrow-.
- Drain off coolant ⇒ [page 147](#)
- Remove toothed belt ⇒ [page 66](#)

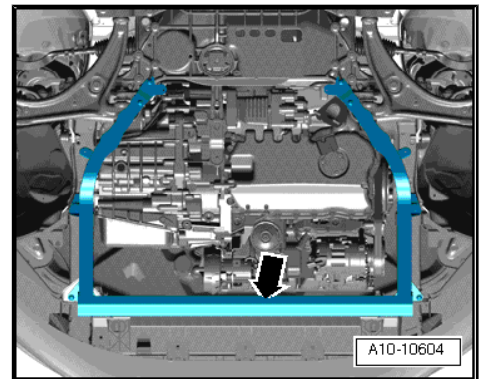

- Unscrew coolant pump securing bolts -1- and remove coolant pump -2-.
- Remove O-ring -3-.

Installing

Installation is carried out in the reverse order; note the following:

- Tightening torques ⇒ [page 144](#)
- Clean and smoothen sealing surface for O-ring.

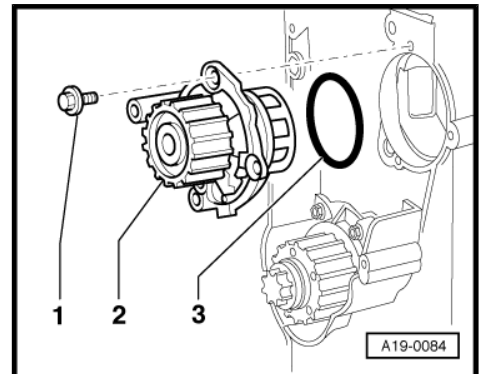

- Coat new O-ring -3- with coolant G12+.

Protected by copyright. Copying for private or commercial purposes, in part or in whole, is not permitted. Please contact Audi AG. Audi AG does not guarantee or accept any liability with respect to the correctness of information in this document. Copyright by Audi AG.

Fit coolant pump -2-

- Installation position: Sealing plug in housing faces downwards.
- Tighten coolant pump bolts -1-.
- Fit toothed belt ⇒ [page 66](#) .
- Install poly V-belt ⇒ [page 33](#) .
- Fill up with coolant ⇒ [page 147](#) .

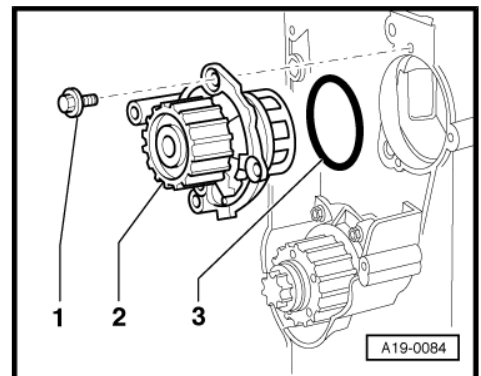

1.9 Radiator and radiator fans - exploded view

1 - Radiator fan -V7-

- Removing and installing ⇒ [page 163](#)

2 - Nut

- 10 Nm

3 - Radiator cowl

4 - Coolant hose (top)

- To connection at cylinder head

5 - O-ring

- Renew if damaged

6 - Radiator

- Removing and installing ⇒ [page 158](#)
- If renewed, change coolant in entire system

7 - O-ring

- Renew if damaged

8 - Coolant hose (bottom)

- To connection for thermostat

9 - Bolt

- 5 Nm
- To charge air cooler

10 - Nut

- 10 Nm

11 - Bolt

- 5 Nm
- To radiator

12 - Radiator fan 2 -V177-

- Removing and installing ⇒ [page 163](#)

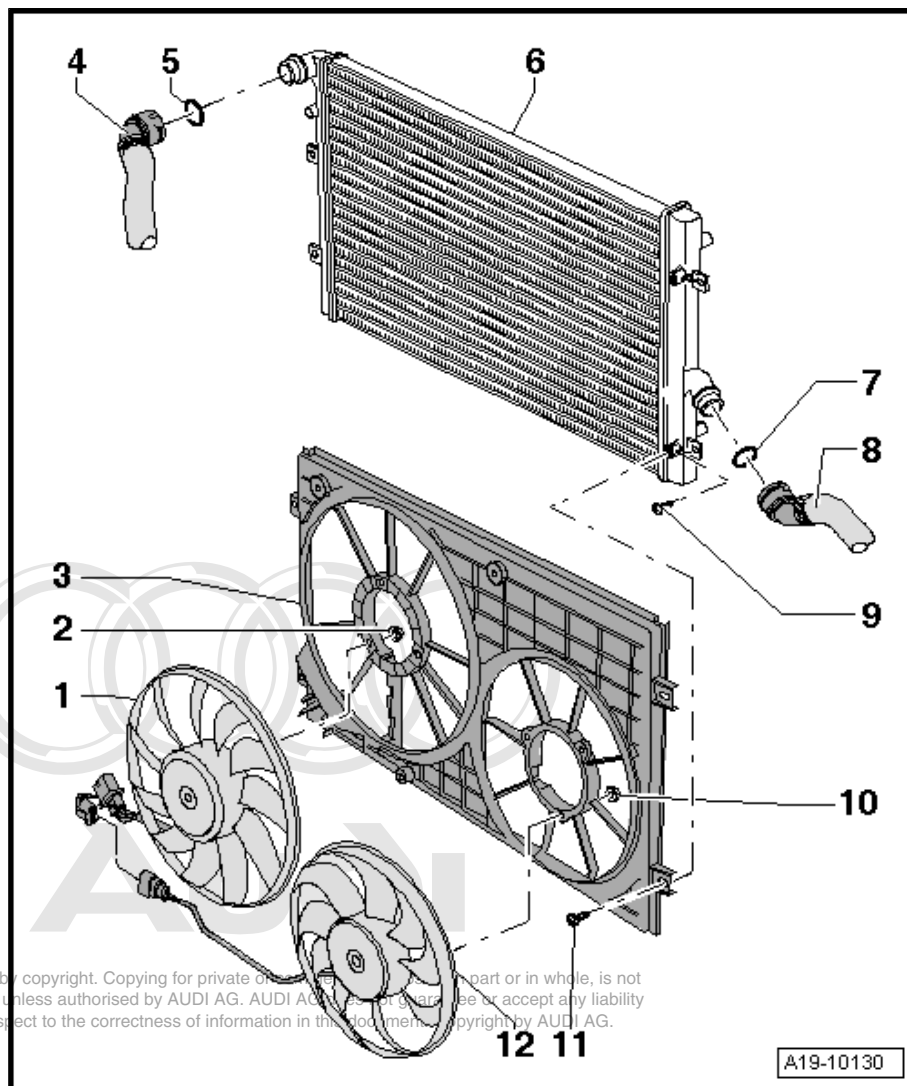

1.10 Removing and installing radiator

Special tools and workshop equipment required

- ◆ Drip tray for workshop hoist -VAS 6208-

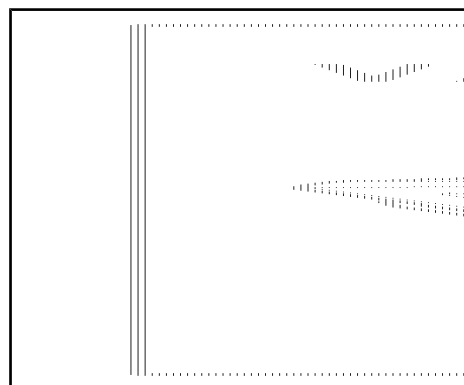

- ◆ Hose clip pliers -V.A.G 1921-

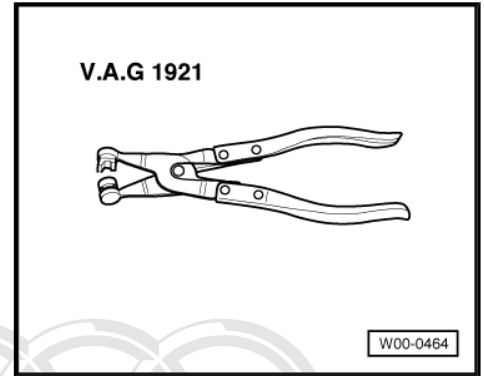

Removing



WARNING

Hot steam/hot coolant may escape when opening expansion tank. Cover cap with cloth and open carefully.

- Open filler cap on coolant expansion tank
- Disconnect intake connecting pipe -arrow- with hose clip pliers -V.A.G 1921- .
- Unbolt air intake connection at front of lock carrier -1- and remove air intake connection.

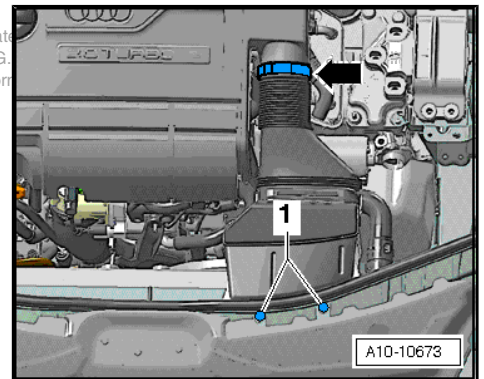

- Unscrew bolts -1- from above.

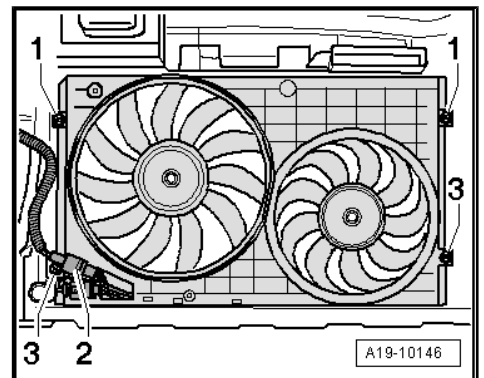



- Remove centre noise insulation -fasteners 1 ... 4-.

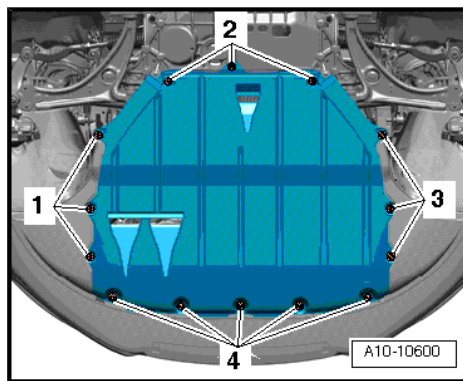

- Remove air pipe -1 and 2- for charge air cooler.

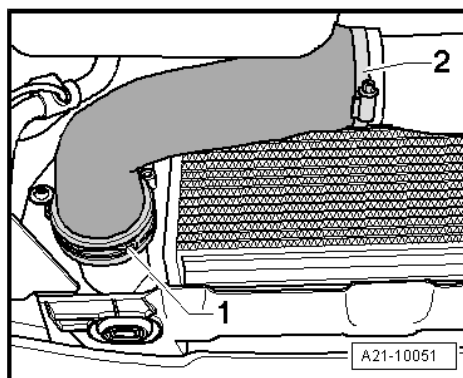

- Remove air pipe -arrows-.

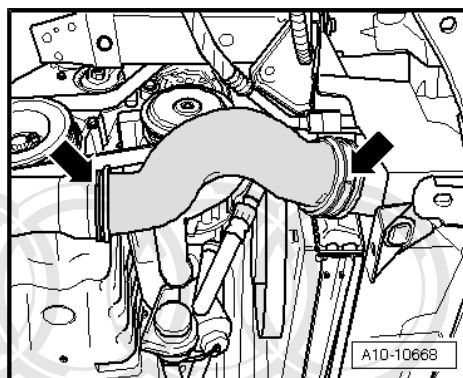

- Unplug electrical connector -2-.
- Unscrew the bolts -3- and remove radiator cowl from below.
- Place drip tray for workshop hoist -VAS 6208- beneath engine.

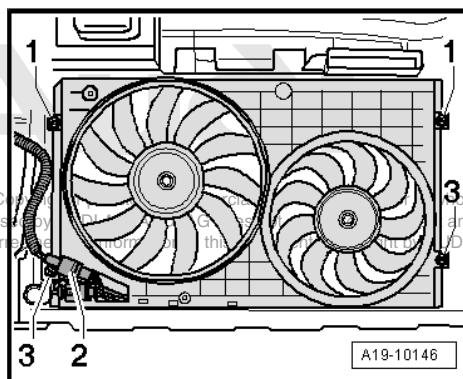

Protected by copyright. Copying or reproduction in any form or by any means, is not permitted unless authorized in writing by Audi AG. Audi AG is not liable for any damage or liability arising from the use of this manual.

- To drain off coolant, detach bottom coolant hose -arrow-.

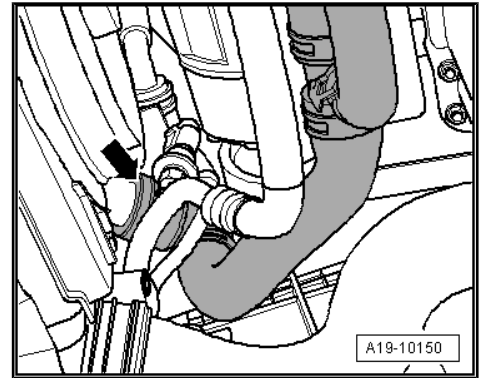

- Detach top coolant hose from radiator -arrow-.

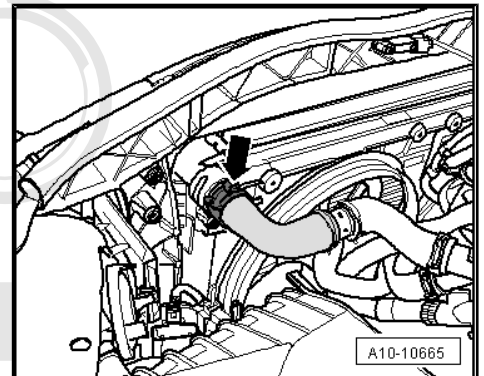

- Unscrew bolts -arrows- on backside of radiator.
- Lift up radiator slightly and remove from below.

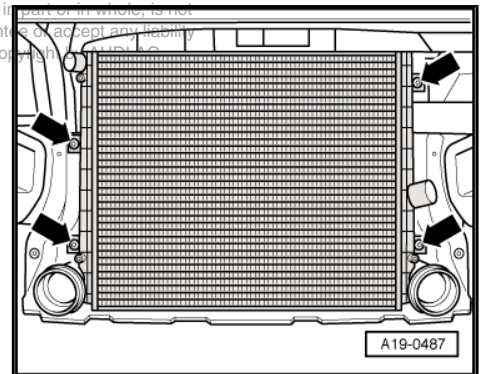

Installing

Installation is carried out in the reverse order; note the following:

- Tightening torques ⇒ [page 158](#)
- Installing air pipes with connectors ⇒ [page 164](#)
- Fill up with coolant ⇒ [page 147](#) .

1.11 Removing and installing radiator cowl

Special tools and workshop equipment required

- ◆ Hose clip pliers -V.A.G 1921-

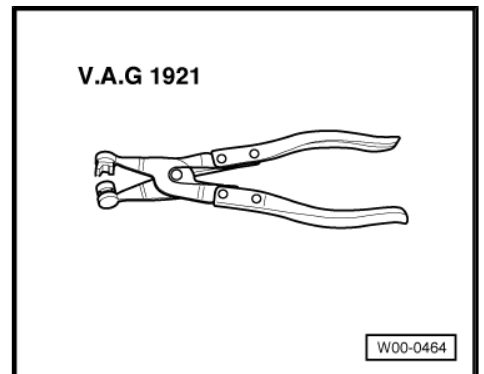



Removing

- Unscrew bolts -1- from above.

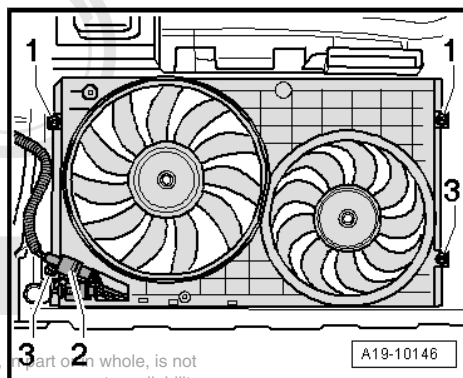

Protected by copyright. Copying for private or commercial purposes, or for the whole or part of a whole, is not permitted unless authorised by AUDI AG. AUDI AG does not guarantee the accuracy or accept any liability with respect to the correctness of information in this document. Copyright by AUDI AG.

- Remove centre noise insulation -fasteners 1 ... 4-.

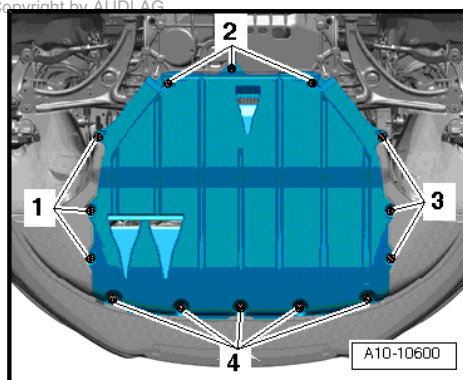

- Remove air pipe -1 and 2- for charge air cooler.

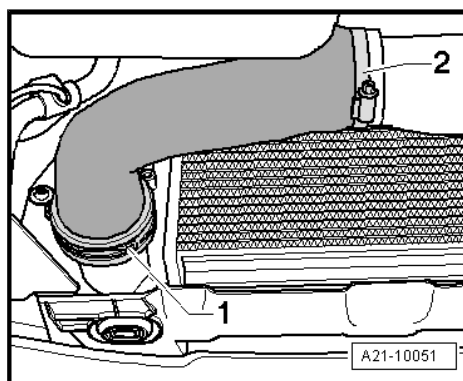

- Unplug electrical connector -2-.
- Unscrew the bolts -3- and remove radiator cowl from below.

Installing

Installation is carried out in the reverse order; note the following:

- Tightening torques ⇒ [page 158](#)
- Installing air pipes with connectors ⇒ [page 164](#)

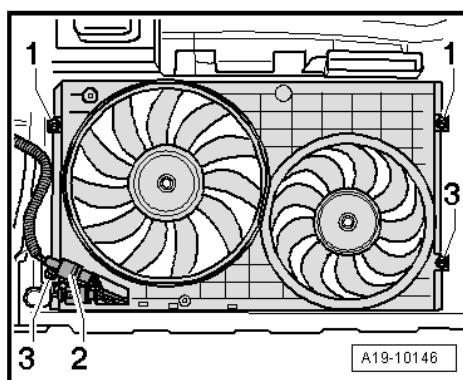

1.12 Removing and installing radiator fan - V7- and radiator fan 2 -V177-

Removing

- Remove radiator cowl ⇒ [page 161](#) .
- Unplug electrical connector -1-.
- Move wiring clear.
- Unscrew nuts -arrows- and remove fans.

Installing

Installation is carried out in the reverse order; note the following:

- Tightening torques ⇒ [page 158](#)
- Install radiator cowl ⇒ [page 161](#) .

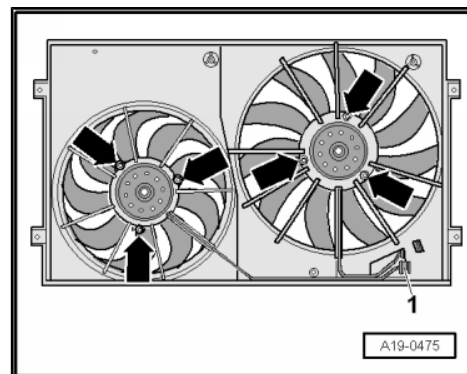

Protected by copyright. Copying for private or commercial purposes, in part or in whole, is not permitted unless authorised by AUDI AG. AUDI AG does not guarantee or accept any liability with respect to the correctness of information in this document. Copyright by AUDI AG.



21 – Turbocharging/supercharging

1 Turbocharger



Note

- ◆ Observe the rules for cleanliness ⇒ [page 4](#)
- ◆ Secure all hose connections with the correct type of hose clips (same as original equipment). ate or commercial purposes, in part or in whole, is not permitted unless authorised by AUDI AG. AUDI AG does not guarantee or accept any liability
- ◆ Hose connections and hoses for charge air system must be free of oil and grease before assembly. However (applies only to plug-in connectors); the seal and the sealing surface of plug-in connectors should be lubricated lightly with oil ⇒ [page 164](#).
- ◆ Charge air system must be free of leaks.
- ◆ Renew self-locking nuts.
- ◆ Hose clip pliers -V.A.G 1921- or spring-type clip pliers -VAS 5024A- are recommended for installing spring-type hose clips.
- ◆ Fill turbocharger with engine oil at connection for oil supply pipe.
- ◆ After installing turbocharger, allow engine to idle for approx. 1 minute and do not rev up immediately to ensure turbocharger is supplied with oil.

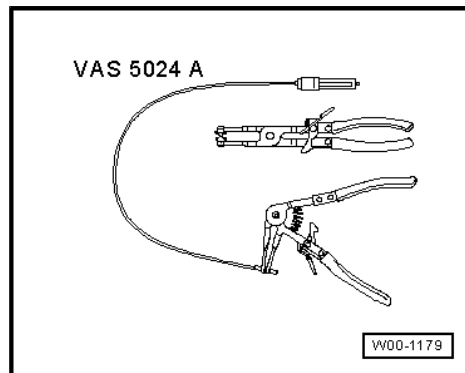

Fitting hose connections with plug-in connectors ⇒ [page 164](#)

1.1 Fitting hose connections with plug-in connectors



Caution

The seal in the plug-in connector can be damaged if the securing clip is in the locked position when fitting the connector. This can cause leakage. Note assembly instructions.

Removing:

- Release plug-in connector by pulling out retaining clip -arrow-. Disconnect pipe/hose (do not use tools of any kind).

Installing

- When renewing seal, fit seal in groove on charge air hose. Make sure that the seal is correctly seated in the groove all round the complete circumference and that it is not twisted.
- Lubricate sealing surface and seal with oil.

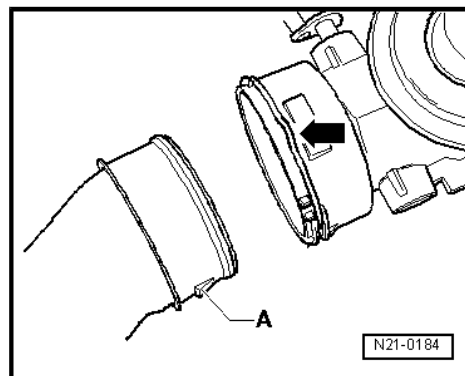

- Move securing clip to released position -1-.
- Push charge air hose into connector as far as stop.
- Move securing clip to locked position -2- and press charge air hose in once again.
- Then pull hose to check that it is fitted correctly and that plug-in connector is locked.

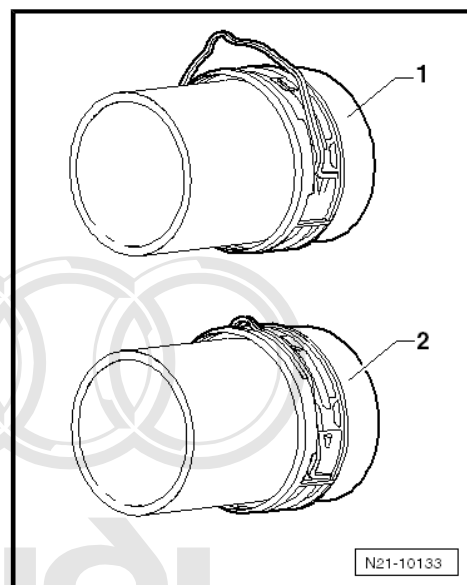

1.2 Turbocharger - exploded view

Part I

Part II ⇒ [page 167](#)

Part III ⇒ [page 168](#)

Part IV ⇒ [page 169](#)

Protected by copyright. Copying for private or commercial purposes, in part or in whole, is not permitted unless authorised by AUDI AG. AUDI AG does not guarantee or accept any liability with respect to the correctness of information in this document. Copyright by AUDI AG.



1 - Turbocharger

- Can only be renewed together with exhaust manifold and vacuum unit as one unit
- Removing and installing => [page 170](#)

2 - Gasket

- Renew

3 - Bolt

- 9 Nm

4 - Crankcase breather hose

5 - Heat shield

6 - ACF line

7 - Vacuum unit/pressure actuator for turbocharger

- Checking => [page 177](#)
- Removing and installing => [page 179](#)
- Adjusting => [page 179](#)

8 - Nipple

9 - Seal

- Renew

10 - Hose

11 - Hose

12 - Bolt

- 3 Nm

13 - Charge pressure control solenoid valve -N75-

14 - Bolt

- 8 Nm

15 - Seal

- Renew

16 - Connection

17 - Securing clip

18 - Bolt

- 9 Nm

19 - Hose

20 - Bolt

- 7 Nm

21 - Mounting bracket

22 - Bolt

- 7 Nm

23 - Turbocharger air recirculation valve -N249-

- Note installation position => [page 167](#)

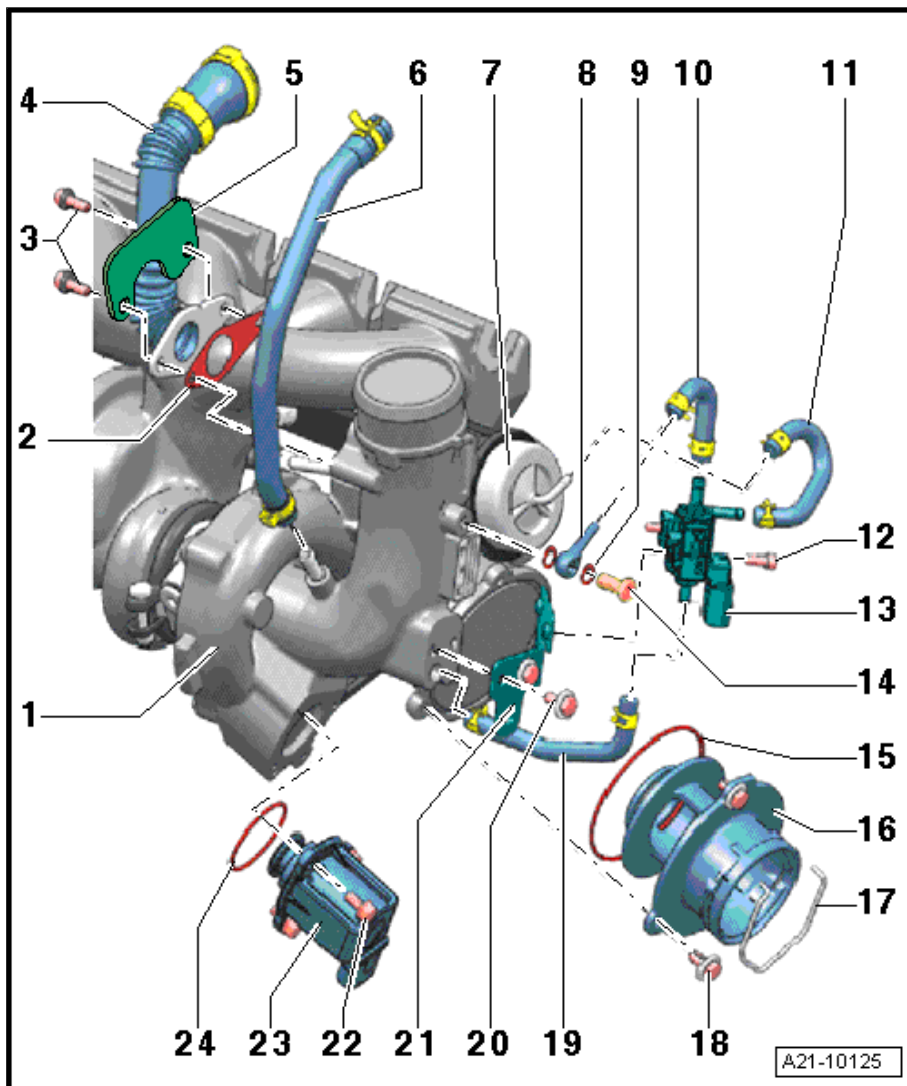

Audi

Protected by copyright. Copying for private or commercial purposes, in part or in whole, is not permitted unless authorised by AUDI AG. AUDI AG does not guarantee or accept any liability with respect to the correctness of information in this document. Copyright by AUDI AG.

24 - Seal

- Renew

Fitting location of turbocharger air recirculation valve -N249-

– Heed installation position -arrows-.

Part II

Part I ⇒ [page 165](#)

Part III ⇒ [page 168](#)

Part IV ⇒ [page 169](#)

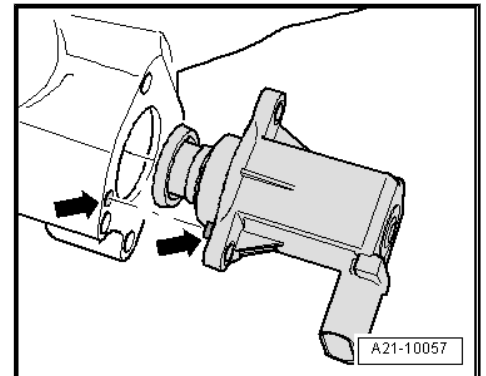
**1 - Seal**

- Renew

2 - Bolt

- 30 Nm

3 - Oil supply pipe**4 - Turbocharger**

- Can only be renewed together with exhaust manifold and vacuum unit as one unit
- Removing and installing ⇒ [page 170](#)

5 - Bolt

- 9 Nm

6 - Bolt

- 30 Nm

7 - Seal

- Renew

8 - Bolt

- 35 Nm

9 - Seal

- Renew

10 - Coolant supply pipe**11 - Bolt**

- 23 Nm

12 - Bolt

- 23 Nm

13 - Bolt

- 9 Nm

14 - Seal

- Renew

15 - Gasket

- Renew

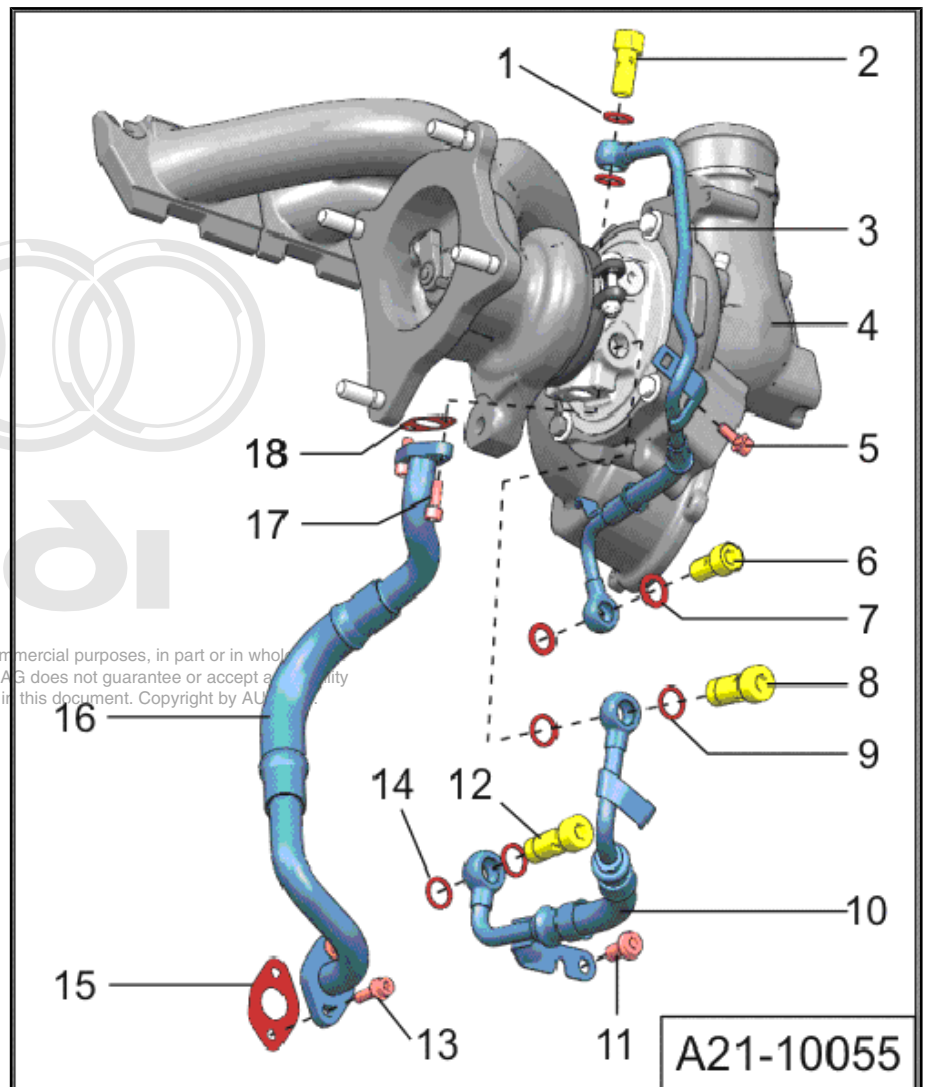

Protected by copyright. Copying for private or commercial purposes, in part or in whole, is prohibited without the prior written permission of Audi AG. Audi AG does not guarantee or accept any liability with respect to the correctness of information in this document. Copyright by Audi AG.



16 - Oil return pipe

17 - Bolt

- 9 Nm

18 - Gasket

- Renew

Part III

Part I ⇒ [page 165](#)

Part II ⇒ [page 167](#)

Part IV ⇒ [page 169](#)



1 - Gasket

- Renew

2 - Nut

- 21 Nm
- Renew
- Coat studs of exhaust manifold with high-temperature paste
- High-temperature paste ⇒ Parts catalogue

3 - Bolt

- 35 Nm

4 - Seal

- Renew

5 - Bolt

- 9 Nm

6 - Coolant return hose/pipe

7 - Turbocharger

- Can only be renewed together with exhaust manifold and vacuum unit as one unit
- Removing and installing ⇒ [page 170](#)

8 - Bracket

9 - Bolt

- 30 Nm
- Lubricate bolts with high-temperature paste
- High-temperature paste ⇒ Parts catalogue

10 - Bolt

- 30 Nm
- Lubricate bolts with high-temperature paste
- High-temperature paste ⇒ Parts catalogue

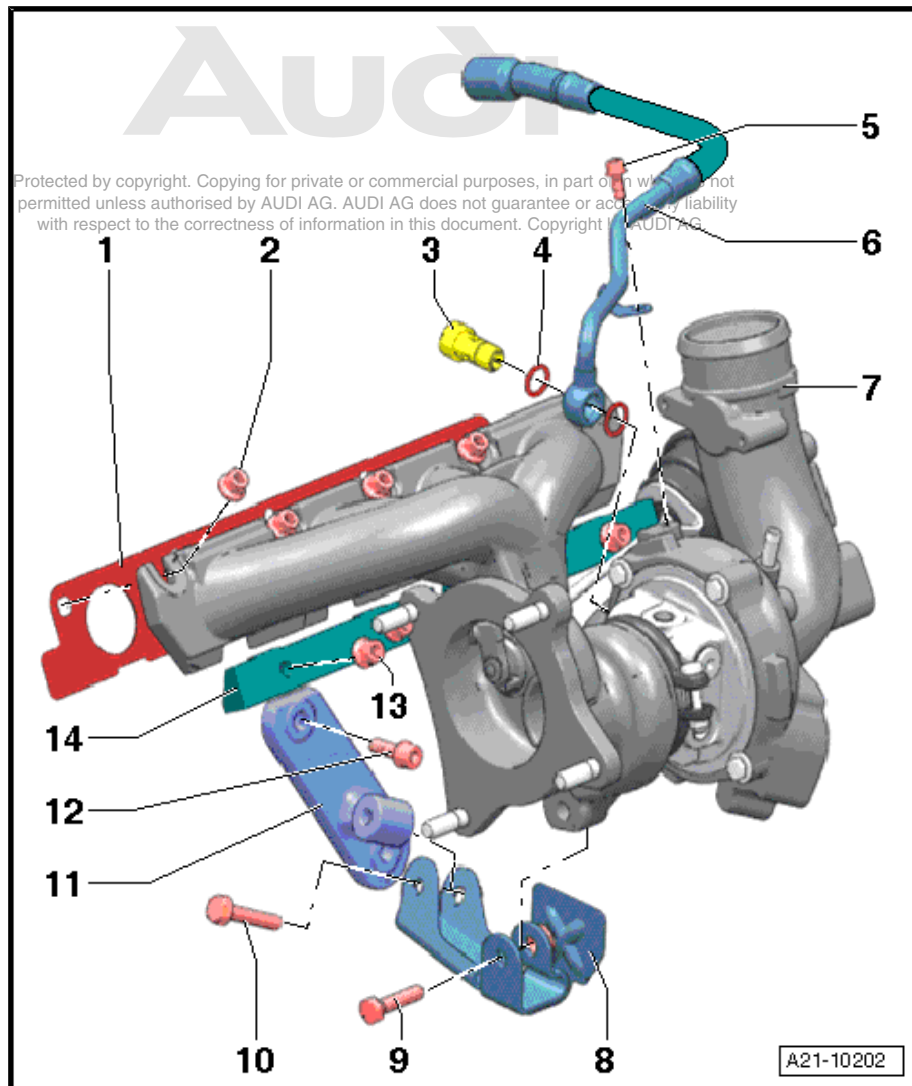

A21-10202

11 - Bracket**12 - Bolt**

- 23 Nm

13 - Nut

- 30 Nm
- Do not open when removing turbocharger
- Renew
- Coat studs of exhaust manifold with high-temperature paste
- High-temperature paste ⇒ Parts catalogue

14 - Fastening strip**Part IV**Part I ⇒ [page 165](#)Part II ⇒ [page 167](#)Part III ⇒ [page 168](#)**1 - Turbocharger**

- Can only be renewed together with exhaust manifold and vacuum unit as one unit
- Removing and installing ⇒ [page 170](#)

2 - Vacuum unit for turbocharger

- Checking ⇒ [page 177](#)
- Removing and installing ⇒ [page 179](#)
- Adjusting ⇒ [page 179](#)

3 - Bolt

- 10 Nm

4 - Locking plate**5 - Nut**

- 9 Nm
- Secure with sealing paint
- Sealing paint ⇒ Parts catalogue

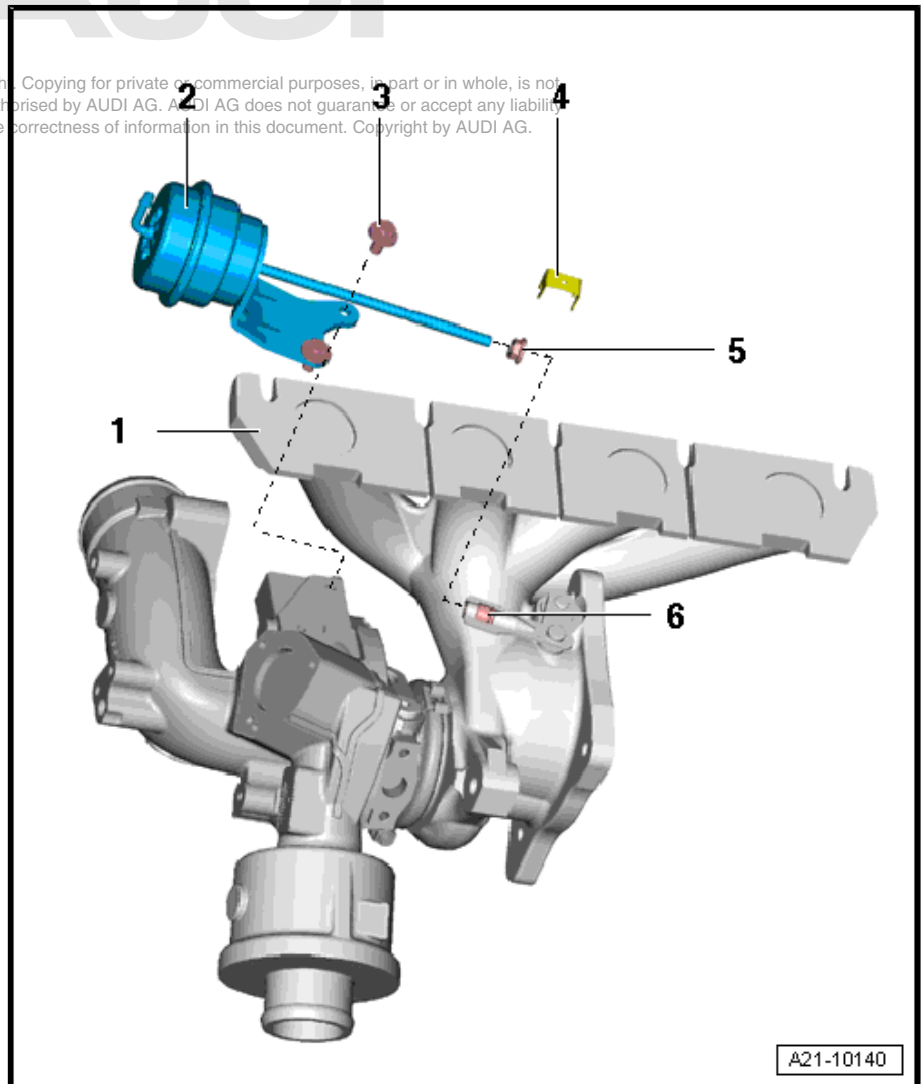
6 - Knurled nut



Further tightening torques

Component	Nm
Charge air pipe (right-side) to sump	10
Charge air pipe (rear) to bracket	10
Oil supply pipe to oil filter bracket	25

1.3 Removing and installing turbocharger

Special tools and workshop equipment required

- ◆ Hose clip pliers -V.A.G 1921-

Protected by copyright. Copying for private or commercial purposes, in part or in whole, is not permitted unless authorised by AUDI AG. AUDI AG does not guarantee or accept any liability with respect to the correctness of information in this document. Copyright by AUDI AG.

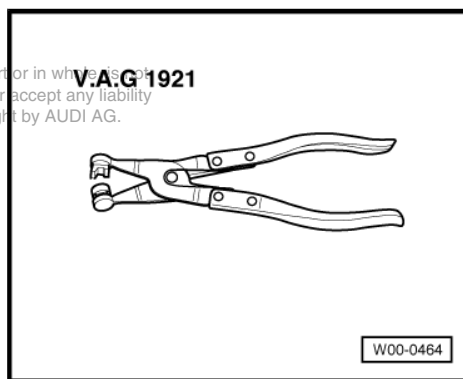

- ◆ Tensioning strap -T10038-

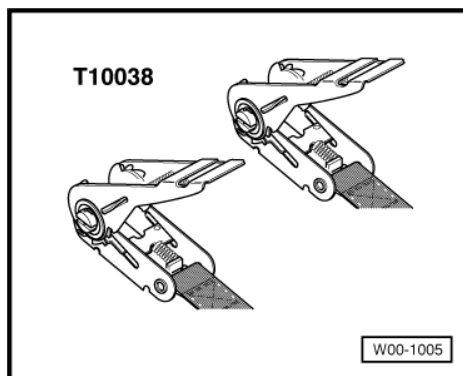

- ◆ Lambda probe open ring spanner set -3337-

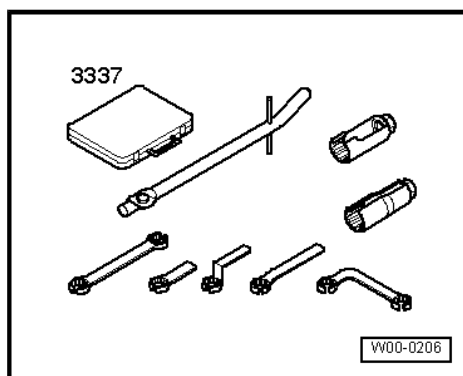

Removing

- Unplug electrical connector at air mass meter -G70- -3-.
- Open clamps -1 and 2- and disconnect air intake hose from air mass meter.
- Detach air intake connection at lock carrier -4-.
- Pull off engine cover panel.

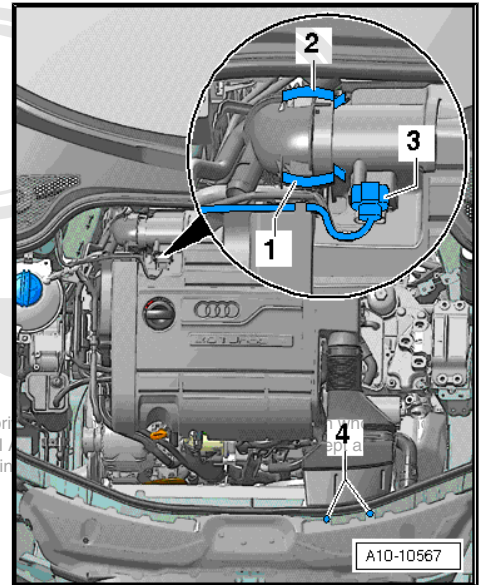

Protected by copyright. Copying for private use is permitted unless authorised by AUDI AG. All rights reserved with respect to the correctness of information.

- Remove air intake hose -arrow- using hose clip pliers -V.A.G 1921- .

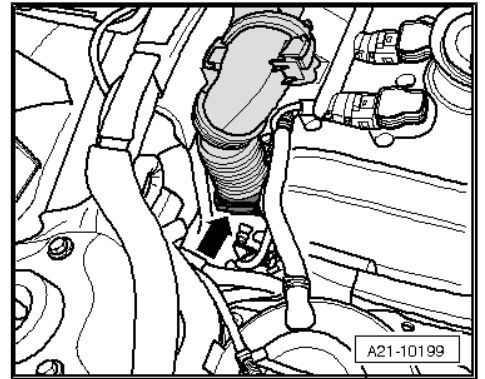

- Unplug connectors -1- on ignition coils.



WARNING

Hot steam/hot coolant may escape when opening expansion tank. Cover cap with cloth and open carefully.

- Open filler cap on coolant expansion tank
- Drain off coolant ⇒ [page 147](#)

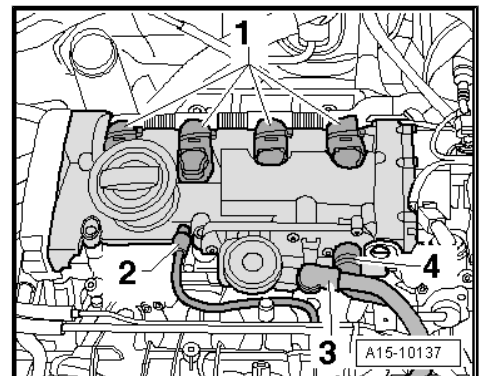

- Disconnect coolant pipe going to coolant expansion tank -arrow-.

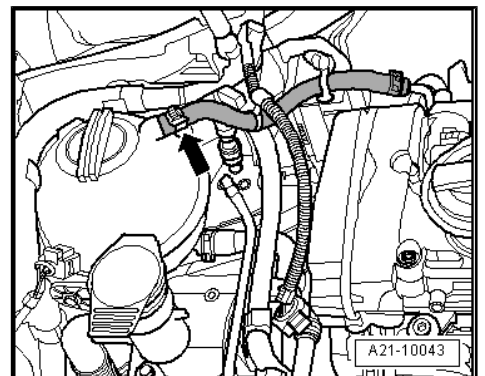



- Disconnect coolant hose -1-.
- Disconnect coolant hose -2-.
- Unscrew coolant line -3-.



Note

Shown in illustration from rear with engine removed.

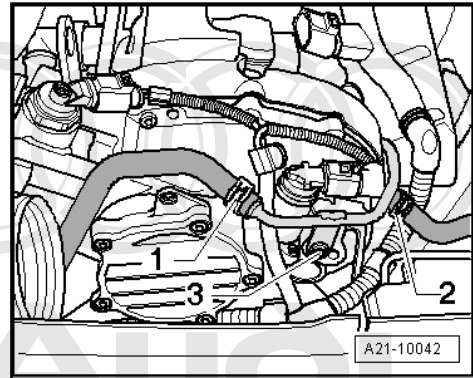

- Remove heat shield -arrows-.

Protected by copyright. All rights reserved. No part of this publication may be reproduced, stored in a retrieval system, or transmitted in any form or by any means, electronic, mechanical, photocopying, recording, or by any information storage and retrieval system, without the prior written permission of Audi AG.

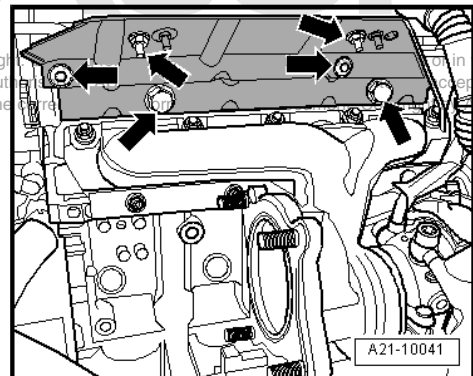

- Unscrew crankcase breather line with heat shield from turbocharger -1-.
- Disconnect crankcase breather line from cylinder head cover -2- and remove.
- Disconnect ACF line going to turbocharger from cylinder head cover -3-.
- Unscrew oil supply pipe from turbocharger -4-.

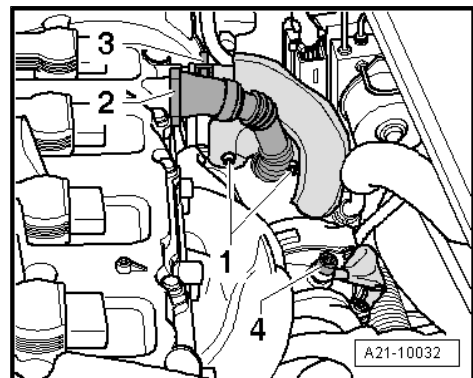

- Remove electrical connector -arrow- for Lambda probe -G39- and Lambda probe heater -Z19- (before catalytic converter) from bracket, unplug and move clear.

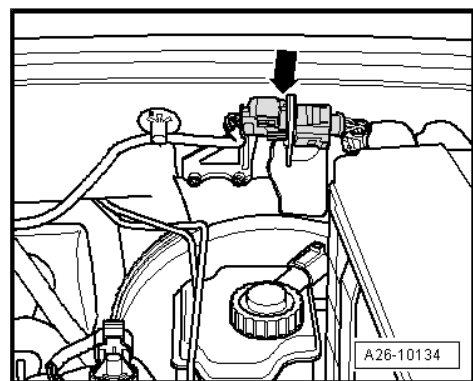

- Unscrew Lambda probe -G39- -arrow- using tool from Lambda probe open ring spanner set -3337- .
- Remove catalytic converter with front exhaust pipe
=> [page 191](#)

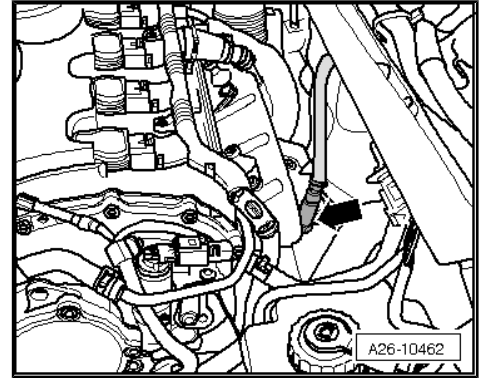

- Remove centre noise insulation -fasteners 1 ... 4-

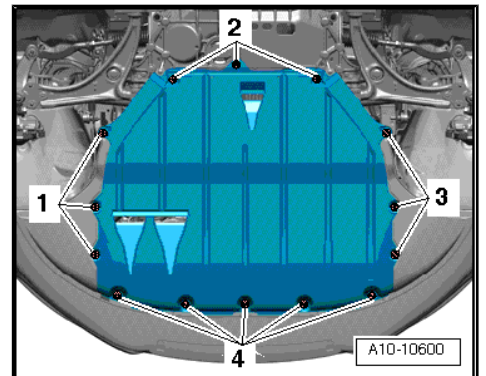

- Remove right noise insulation -arrows-

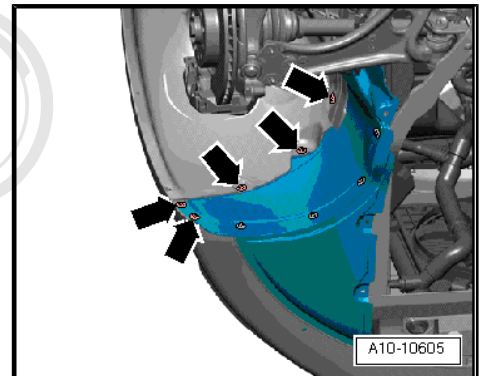

- Remove noise insulation frame -arrow-
- Remove drive shaft (right-side) => Rep. Gr. 40

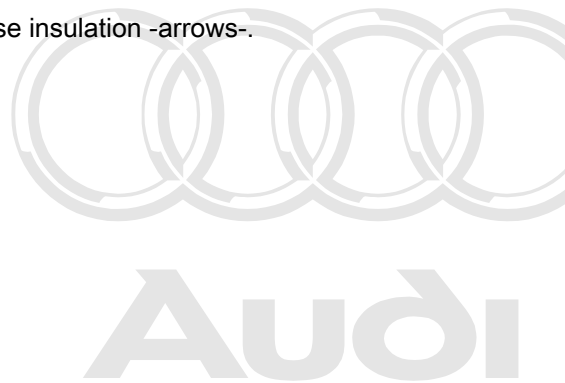
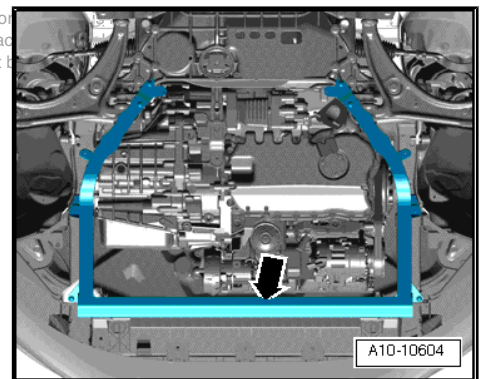



- Unbolt heat shield for drive shaft (right-side) -arrows-

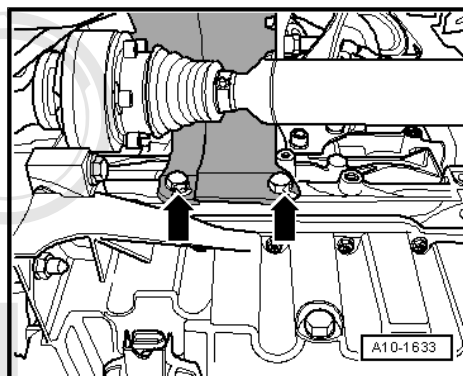

- Detach air pipe -arrow- from charge air cooler.

Protected by copyright. Copying for private or commercial purposes, in part or in whole, is not permitted unless authorised by AUDI AG. AUDI AG does not guarantee or accept any liability with respect to the correctness of information in this document. Copyright by AUDI AG.

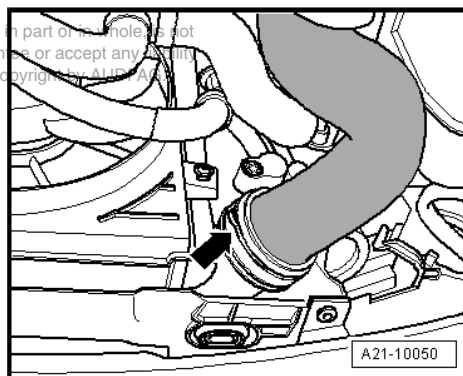

- Unbolt air pipe from turbocharger -arrows-.
- Detach electrical connectors -1 and 2- and move wire clear.

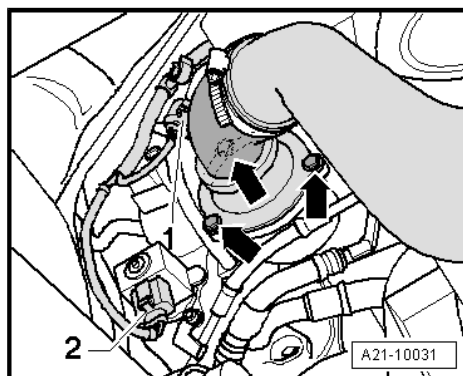

- Unscrew bolts -arrows- and remove air pipe.



Note

Shown in illustration from rear with engine removed.

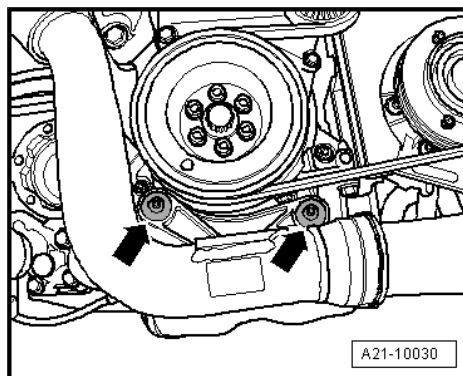

- Unscrew oil supply pipe from turbocharger -2-.

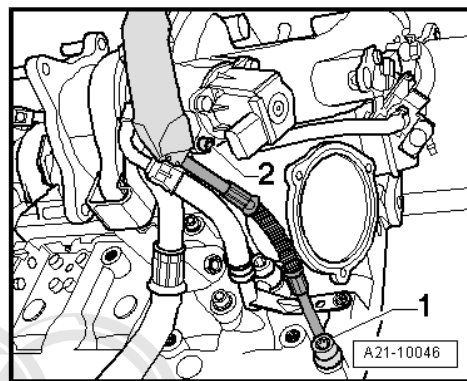

- Unscrew coolant supply pipe at turbocharger -2-.

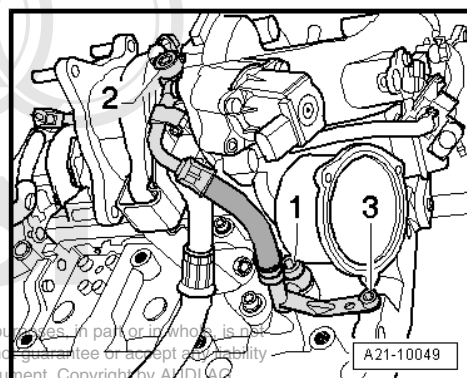

Protected by copyright. Copying for private or commercial purposes in part or in whole is not permitted unless authorised by AUDI AG. AUDI AG does not guarantee or accept responsibility with respect to the correctness of information in this document. Copyright by AUDI AG

- Remove oil return pipe -arrows- at turbocharger.

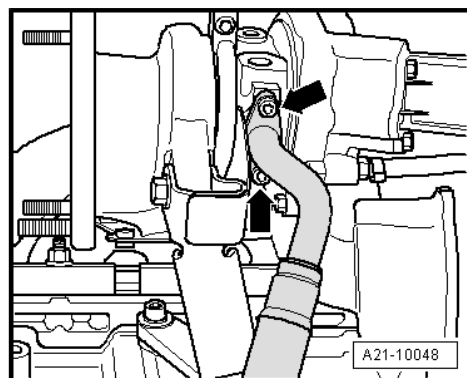

- Remove bolts -1- and -2- and remove support for turbocharger.

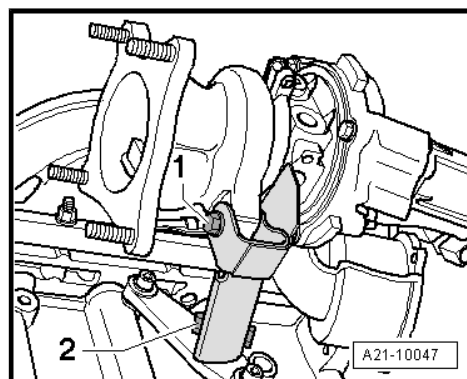



- Remove bolts -1 ... 3- and take out pendulum support.

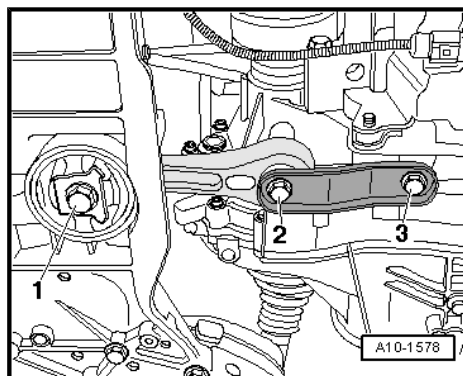

- Fit bolt -1-.
- Use tensioning strap -T10038- to move engine towards the front.



Note

Make sure there is sufficient clearance around engine and turbo-charger.

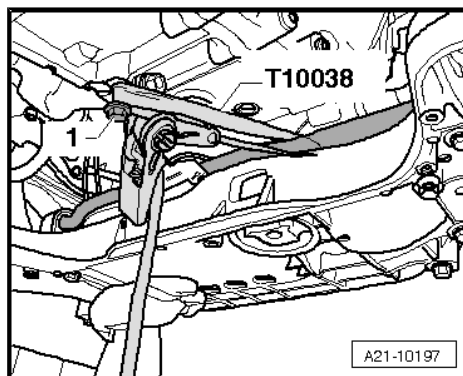

- Disconnect coolant pipe -arrow-.



Note

- ◆ Shown in illustration from rear with engine removed.
- ◆ Do not unscrew nuts on fastening strip (bottom).

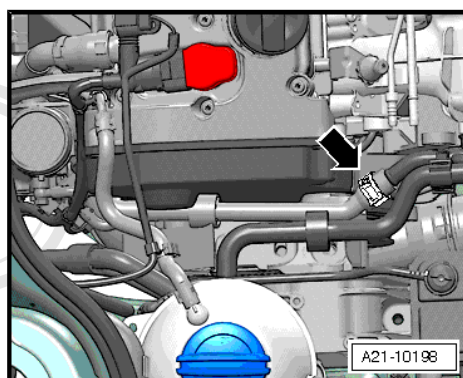

- Unscrew top nuts -arrows-.
- Lift out turbocharger/exhaust manifold.

Installing

Protected by copyright. Copying for private or commercial purposes, in part or in full, is not permitted unless authorised by AUDI AG. AUDI AG does not guarantee the accuracy of the information with respect to the correctness of information in this document. Copyright © Audi AG 2006

Installation is carried out in the reverse order; note the following:

- Tightening torques ⇒ [page 165](#)



Note

- ◆ Renew seals, gaskets and self-locking nuts.
- ◆ Fill turbocharger with engine oil at connection for oil supply pipe.
- ◆ Hose connections and hoses for charge air system must be free of oil and grease before assembly.
- ◆ Secure all hose connections with the correct type of hose clips (same as original equipment) ⇒ *Parts catalogue*.

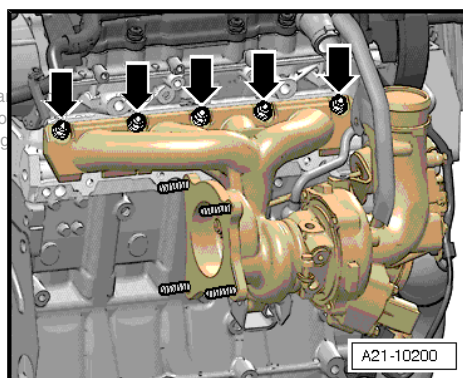

- Position turbocharger as shown in illustration when fitting.
- Install exhaust system and align it free of stress
⇒ [page 194](#) .
- Install Lambda probe -G39- ⇒ Rep. Gr. 24 .
- Install drive shaft ⇒ Rep. Gr. 40 .
- Installing air pipes with connectors ⇒ [page 164](#)
- Fill up with coolant ⇒ [page 147](#) .
- Check oil level ⇒ Maintenance ; Booklet 810 .

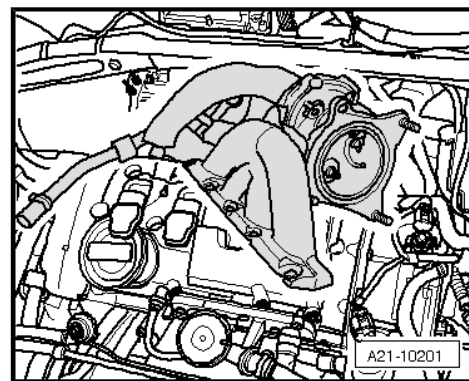

 **Note**

After installing turbocharger, allow engine to idle for approx. 1 minute and do not rev up immediately to ensure turbocharger is supplied with oil.

1.4 Checking vacuum unit for turbocharger

Special tools and workshop equipment required

- ◆ Hand-operated vacuum pump -VAS 6213-

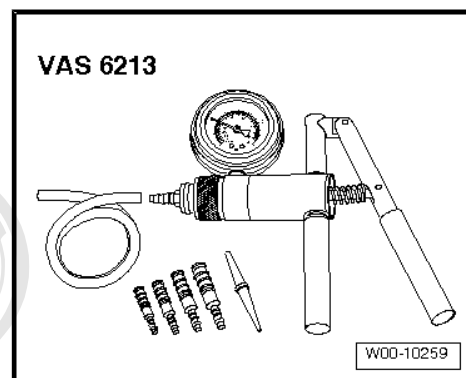

Test condition:

- ◆ Hose from turbocharger via charge pressure solenoid valve - N75- to vacuum unit must not be blocked.
- ◆ Charge pressure control solenoid valve -N75- OK.

Protected by copyright. Copying for private or commercial purposes, in part or in whole, is not permitted unless authorised by AUDI AG. AUDI AG does not guarantee or accept any liability with respect to the correctness of information in this document. Copyright by AUDI AG.



Procedure:

- Unplug electrical connector at air mass meter -G70- -3-.
- Open clamps -1 and 2- and disconnect air intake hose from air mass meter.
- Detach air intake connection at lock carrier -4-.
- Pull off engine cover panel.

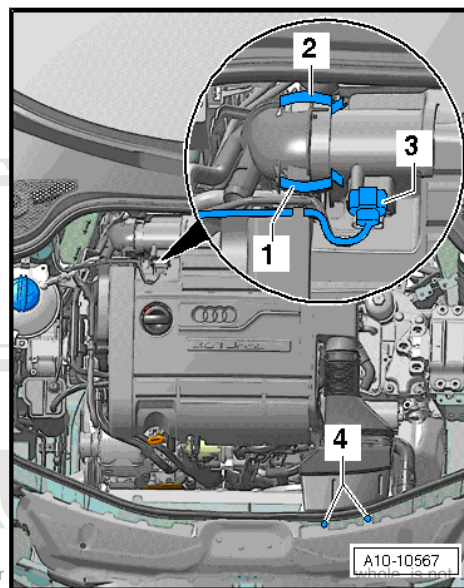

Protected by copyright. Copying for permitted unless authorised by AUDI AG. AUDI AG does not guarantee or accept any liability with respect to the correctness of information in this document. Copyright by AUDI AG.

- Connect hand-operated vacuum pump -VAS 6213- to vacuum unit -arrow-.

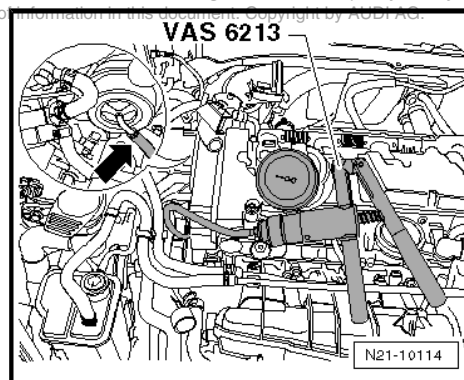

- Move adjuster ring -1- on hand-operated vacuum pump -VAS 6213- to position -B- to select "pressure".



Caution

The pressure must not exceed 750 mbar. The vacuum unit could be damaged if the pressure is exceeded.

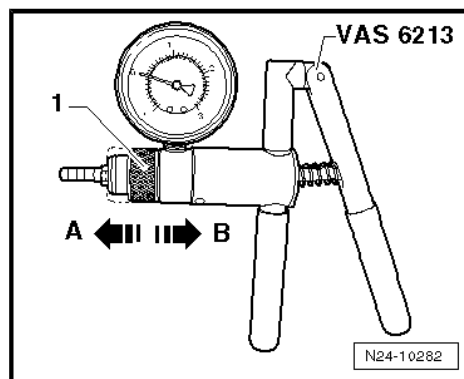

- Operate hand-operated vacuum pump -VAS 6213- several times and at the same time observe linkage.

The linkage -A- should start to move at a pressure of approx. 300 mbar and be at its limit stop at a pressure of approx. 700 mbar.

The linkage should travel approx. 10 mm.

 **Note**

If it is not possible to build up pressure with hand-operated vacuum pump -VAS 6213- or if the pressure drops again immediately, check hand-operated vacuum pump -VAS 6213- and connecting hoses for leaks. If no fault is found: renew vacuum unit ⇒ [page 179](#).

Protected by copyright. Copying for private or commercial purposes, in part or in whole, is not permitted unless authorised by AUDI AG. AUDI AG does not guarantee or accept any liability with respect to the correctness of information in this document. Copyright by AUDI AG.

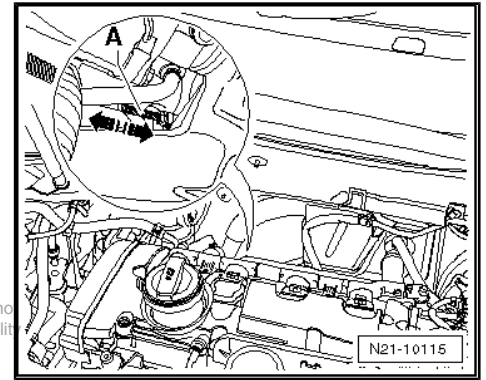

1.5 Removing and installing vacuum unit for turbocharger

Removing

- Remove turbocharger ⇒ [page 170](#)
- Detach locking plate -1- on turbocharger linkage.

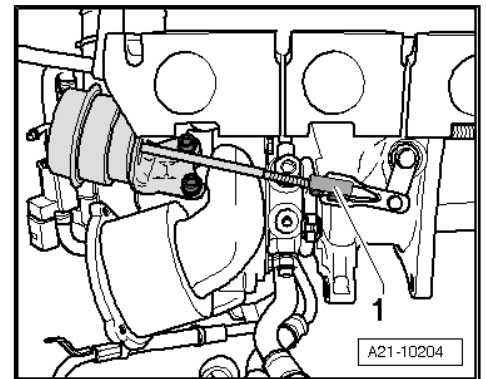

- Loosen lock nut -2-.
- Detach linkage from turbocharger -3-.
- Remove bolts -4- and take out vacuum unit -1-.

Installing

Installation is carried out in the reverse order; note the following:

- Tightening torques ⇒ [page 169](#)
- Adjust vacuum unit for turbocharger ⇒ [page 179](#).
- Install turbocharger ⇒ [page 170](#)

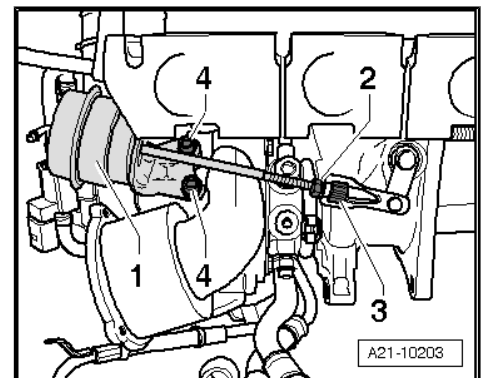

1.6 Adjusting vacuum unit for turbocharger

Turbocharger removed



Special tools and workshop equipment required

- ◆ Universal dial gauge bracket -VW 387-
- ◆ Hand-operated vacuum pump -VAS 6213-
- ◆ Pressure control valve - VAS 6342-
- ◆ Turbocharger tester -V.A.G 1397A-
- ◆ Dial gauge set, 4 pieces - VAS 6341-
- ◆ Torque wrench -V.A.G 1783-

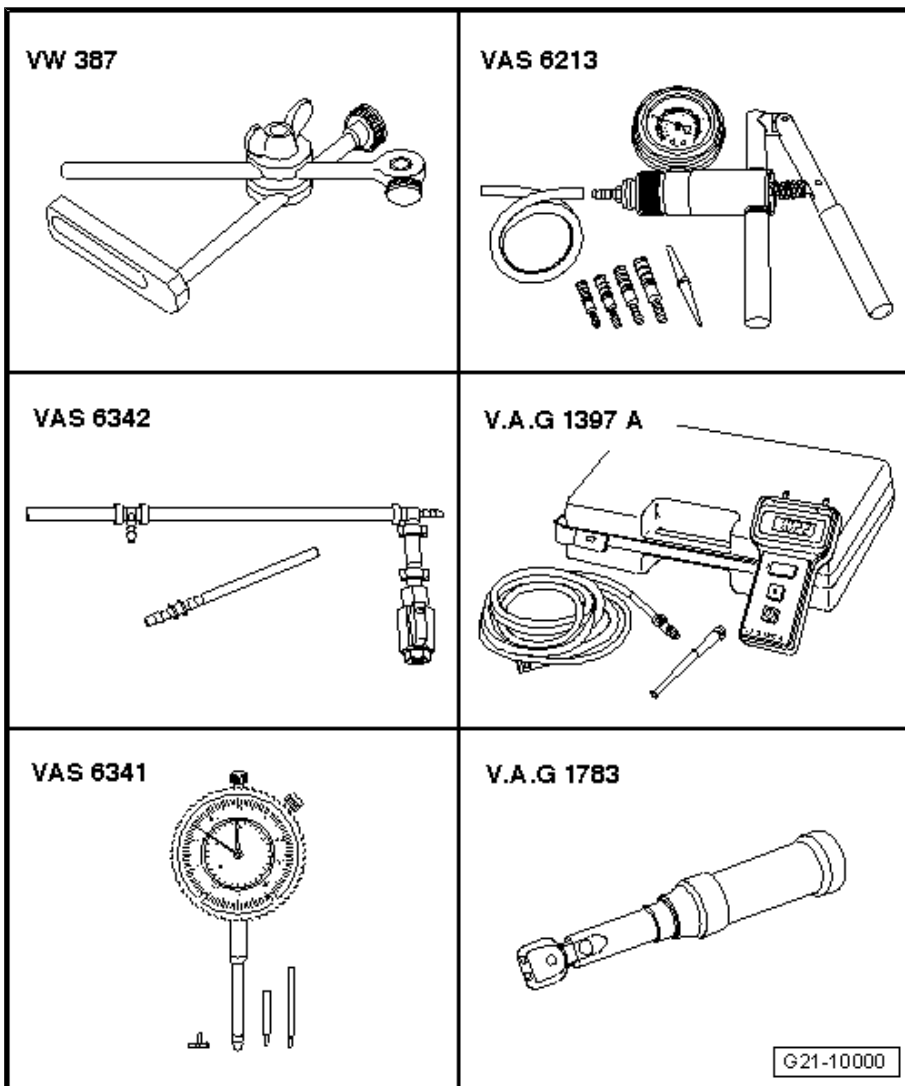

- ◆ Open-end spanner insert AF 10 -V.A.G 1783/1-

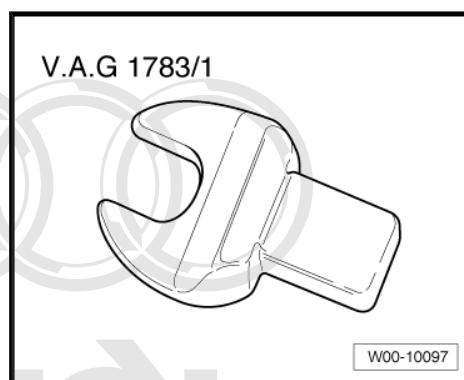

Adjusting

- Tightening torques ⇒ [page 169](#)

Protected by copyright. Copying for private or commercial purposes, in part or in whole, is not permitted unless authorised by AUDI AG. AUDI AG does not guarantee or accept any liability with respect to the correctness of information in this document. Copyright by AUDI AG.

- Disconnect hose -arrow- at vacuum unit on turbocharger.

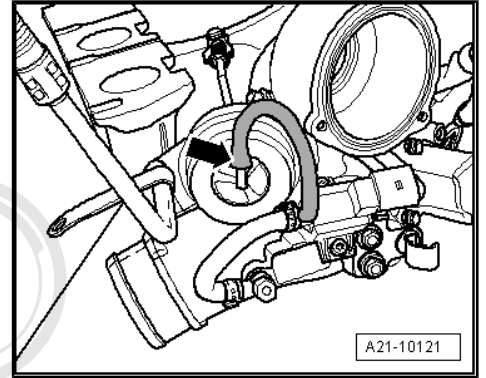

- Detach locking plate -1- on turbocharger linkage.

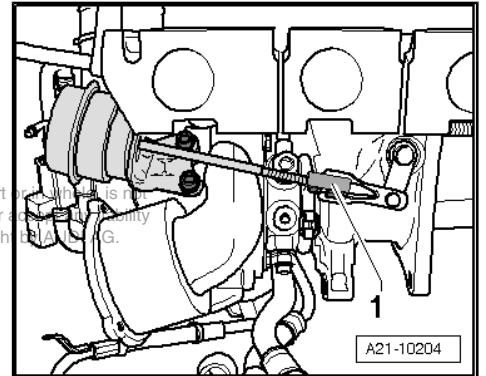

- Loosen lock nut -2-.

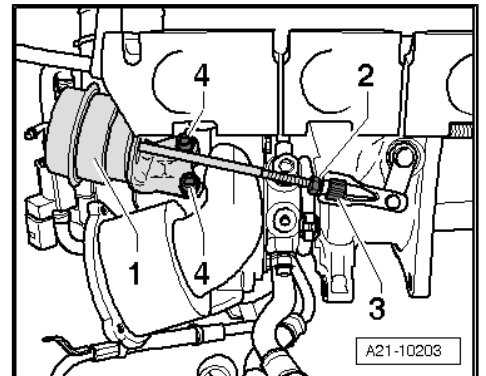

- Pre-adjust bypass flap -1- at knurled nut -arrow- so that bypass flap can still just be turned by hand.
- Hand-tighten lock nut.

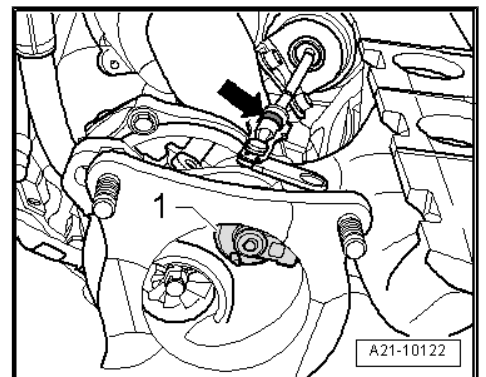

Protected by copyright. Copying for private or commercial purposes, in part or in full, is not permitted unless authorised by AUDI AG. AUDI AG does not guarantee or assume any liability with respect to the correctness of information in this document. Copyright © AUDI AG.



- Connect up hand-operated vacuum pump -VAS 6213- , turbocharger tester -V.A.G 1397A- (connection II) and pressure control valve -VAS 6342- as shown in illustration.
- Close pressure control valve -VAS 6342- at lever -1-.

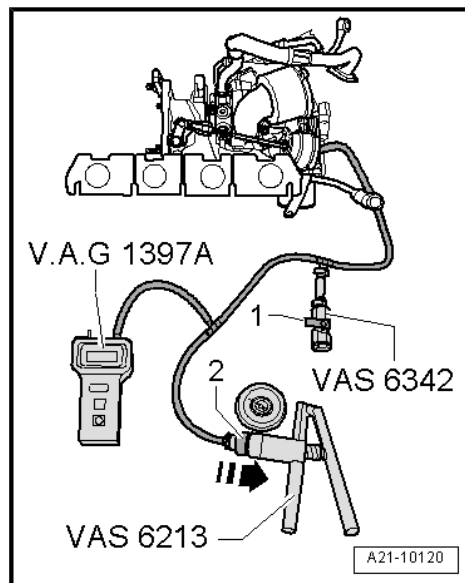

- Move adjuster ring -1- on hand-operated vacuum pump -VAS 6213- to position -B- to select "pressure".
- Switch on turbocharger tester -V.A.G 1397A- and set sliding switch to position II.

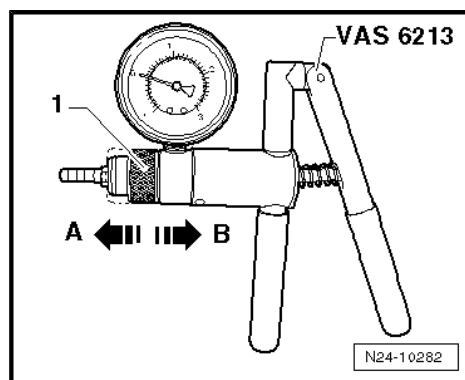

Audi

Protected by copyright. Copying for private or commercial purposes, in part or in whole, is not permitted unless authorised by AUDI AG. AUDI AG does not guarantee or accept any liability with respect to the correctness of information in this document. Copyright by AUDI AG.

- Secure universal dial gauge bracket -VW 387- to turbocharger arrow-.

 **Note**

The dial gauge values (mm) listed here include the 1 mm preload that is initially set on the gauge.

- Attach dial gauge -VAS 6341/1- with extension, 30 mm -VAS 6341/3- and flat probe -VAS 6341/4- to universal dial gauge bracket -VW 387- .
- With pressure at 0 bar, set dial gauge -VAS 6341/1- to 1 mm preload.
- Set scale of dial gauge -VAS 6341/1- to 0.
- Make sure that dial gauge can move freely.
- Operate hand-operated vacuum pump -VAS 6213- until turbocharger tester -V.A.G 1397A- indicates 350 +/- 5 mbar.
- The dial gauge should now indicate a value between 4.1 mm and 4.3 mm. If not, turn knurled nut until this value is indicated.
- Hand-tighten lock nut.
- Repeat measurement.
- Vent system via pressure control valve -VAS 6342- so that pressure reading drops to 0 mbar.
- Set dial gauge -VAS 6341/1- to 0.

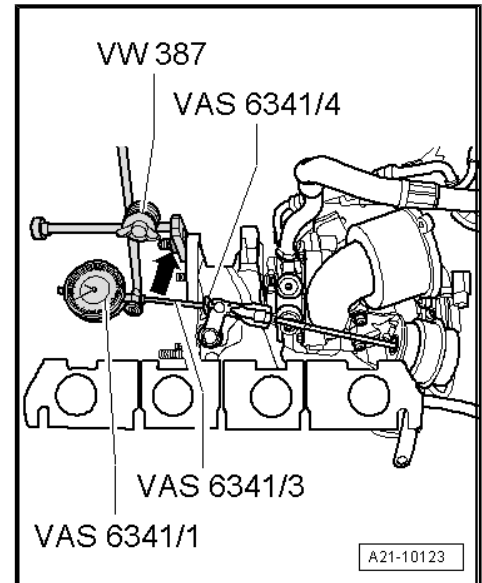

 **Note**

The following measurements must be performed in continuous sequence. Do not allow the pressure to drop to 0 between measurements.

- Operate hand-operated vacuum pump -VAS 6213- until turbocharger tester -V.A.G 1397A- indicates 350 +/- 5 mbar.
 - Read off and note value indicated on dial gauge -VAS 6341/1- .
 - Operate hand-operated vacuum pump -VAS 6213- until turbocharger tester -V.A.G 1397A- indicates 650 to 700 mbar.
 - Vent system via pressure control valve -VAS 6342- so that pressure reading drops to 350 +/- 5 mbar.
 - Read off and note value indicated on dial gauge -VAS 6341/1- .
 - Add values 1 and 2 together and divide by 2.
 - The result (mean value) should be 5 +/- 0.25 mm.
 - If the result (mean value) is not 5 +/- 0.25 mm, correct the setting accordingly, tighten the lock nut hand-tight and repeat the measurement.
 - If the result (mean value) is 5 +/- 0.25 mm, tighten the lock nut and secure with sealing paint. For sealing paint refer to Parts catalogue.
- Permitted unless authorised by AUDI AG. AUDI AG does not guarantee or accept any liability with respect to the correctness of information in this document. Copyright by AUDI AG.



- Secure locking plate -1- on linkage of vacuum unit.

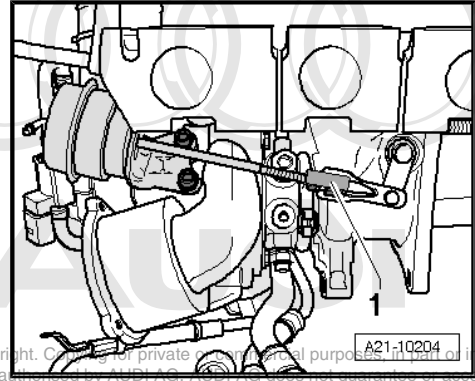

Protected by copyright. Copying for private or non-commercial purposes in whole or in part, is not permitted unless authorized by AUDI AG. AUDI AG does not accept any liability with respect to the correctness of information in this document. Copyright by AUDI AG.

2 Charge air system

Charge air cooler - exploded view of components ⇒ [page 185](#)

Turbocharging diagram ⇒ [page 186](#)

Checking charge air system for leaks ⇒ [page 187](#)

2.1 Charge air cooler - exploded view of components

- 1 - Bolt
 - 5 Nm
- 2 - Mounting
 - For charge air cooler
- 3 - Charge air cooler
- 4 - Charge air pipe
 - Fitting hose connections with plug-in connectors ⇒ [page 164](#)
- 5 - Bolt
 - 10 Nm
- 6 - Charge air hose
 - Fitting hose connections with plug-in connectors ⇒ [page 164](#)
- 7 - Hose clip
- 8 - Charge air hose
 - To throttle valve module -J338-
- 9 - Hose clip
- 10 - Bolt
 - 10 Nm
- 11 - Charge air pipe
- 12 - Hose clip
- 13 - Charge air hose
 - Fitting hose connections with plug-in connectors ⇒ [page 164](#)
- 14 - Seal
 - Renew
- 15 - Charge pressure sender -G31-
- 16 - Bolt
 - 5 Nm
- 17 - Bolts
 - 10 Nm

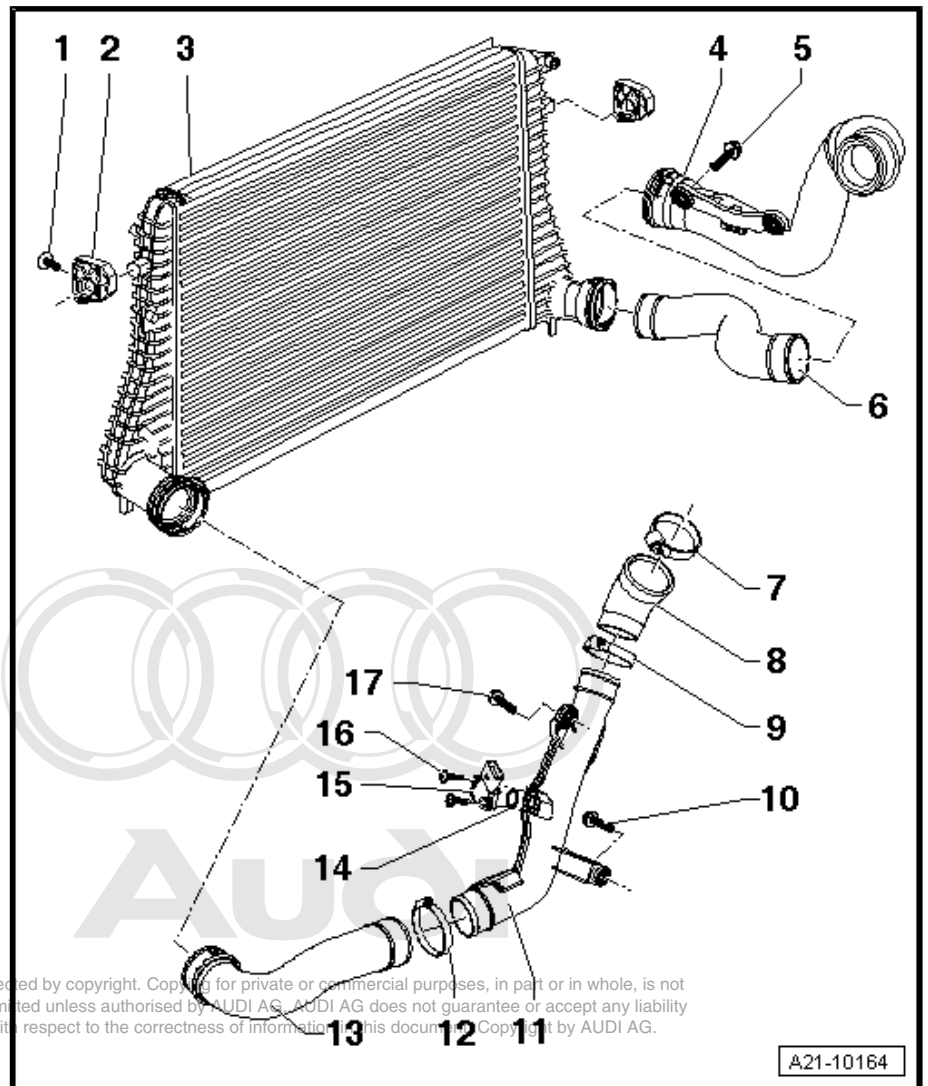

2.2 Turbocharging diagram

- 1 - Vacuum unit
- 2 - Solenoid valve for charge pressure control -N75-
- 3 - Turbocharger air recirculation valve -N249-
- 4 - Turbocharger
- 5 - Brake servo
- 6 - Non-return valve
- 7 - Coolant hose/pipe connection
- 8 - Vacuum pump
- 9 - Non-return valve
- 10 - Oil filter bracket
- 11 - Activated charcoal filter solenoid valve 1 -N80-
- 12 - Dual non-return valve
- 13 - Charge air cooler
- 14 - Throttle valve module - J338-
- 15 - Pressure control valve
- 16 - To activated charcoal filter
- 17 - Air mass meter -G70-

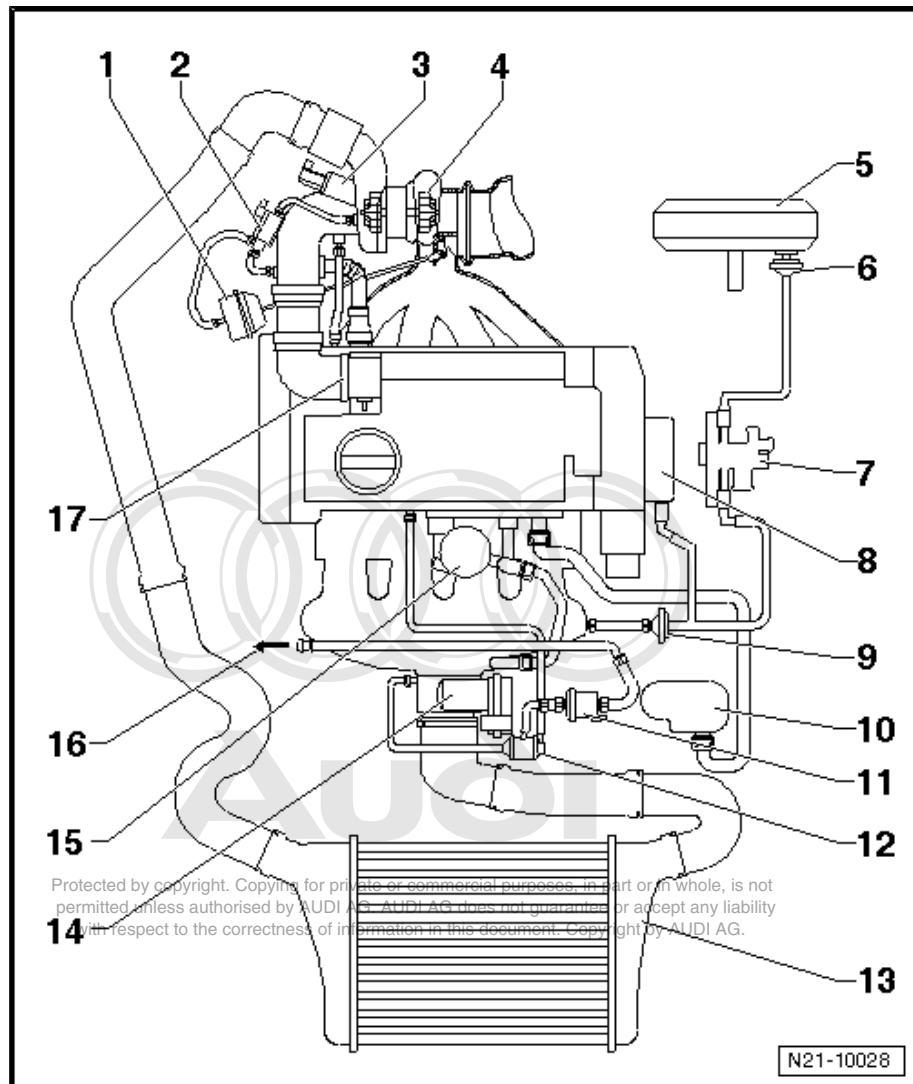

Protected by copyright. Copying for private or commercial purposes, in part or in whole, is not permitted unless authorised by AUDI AG. AUDI AG does not guarantee or accept any liability with respect to the correctness of information in this document. Copyright by AUDI AG.

2.3 Removing and installing charge air cooler

Removing

- Remove radiator ⇒ [page 158](#) .
- Remove front bumper cover ⇒ General body repairs, exterior; Rep. Gr. 63



Note

To prevent damage to the condenser, refrigerant pipes and refrigerant hoses, ensure that the pipes and hoses are not stretched, kinked or bent.

**WARNING**

The air conditioner refrigerant circuit must not be opened.

- Unscrew bolts -arrows-, to do so, release air ducts (left and right) and swivel towards headlights.
- Tilt top edge of charge air cooler slightly to rear.
- Disengage charge air cooler from bottom mounting points by lifting charge air cooler.
- Push charge air cooler towards engine.
- Support charge air cooler from below to prevent it from dropping.

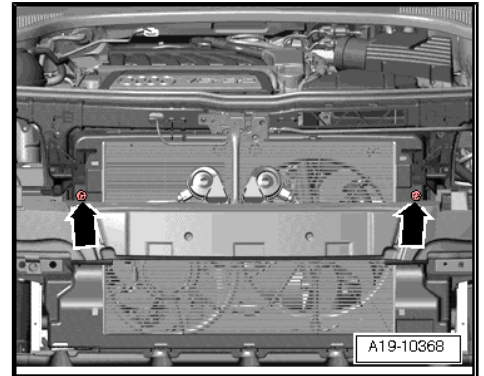

- Remove bolts -arrows-.
- Detach charge air cooler upwards and remove from below.

Installing

Installation is carried out in the reverse order; note the following:

- Tightening torques ⇒ [page 185](#)
- Installing air pipes with connectors ⇒ [page 164](#)
- Fill up with coolant ⇒ [page 147](#) .
- Install front bumper cover ⇒ General body repairs, exterior; Rep. Gr. 63

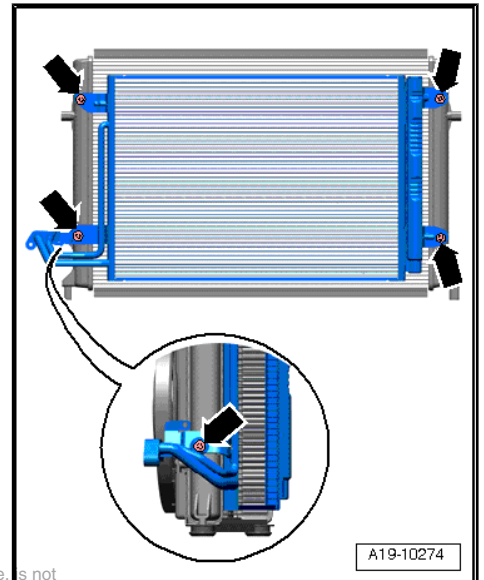

Protected by copyright. Copying for private or commercial purposes, in part or in whole, is not permitted unless authorised by AUDI AG. AUDI AG does not guarantee or accept any liability with respect to the correctness of information in this document. Copyright by AUDI AG.

2.4 Checking charge air system for leaks

Special tools and workshop equipment required

- ◆ Charge air system tester -V.A.G 1687-

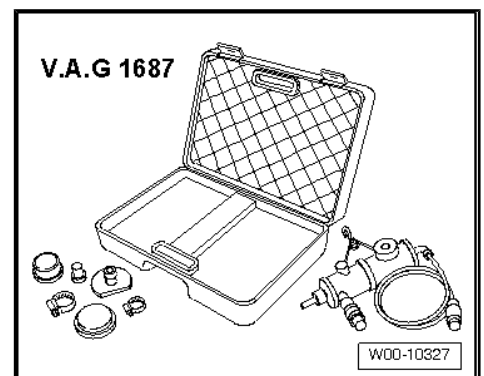

- ◆ Adapter -V.A.G 1687/5-

- Remove noise insulation tray ⇒ General body repairs, exterior; Rep. Gr. 50 ; Body - front, noise insulation .



- Release clip -A- and detach hose -B- from charge air pipe.

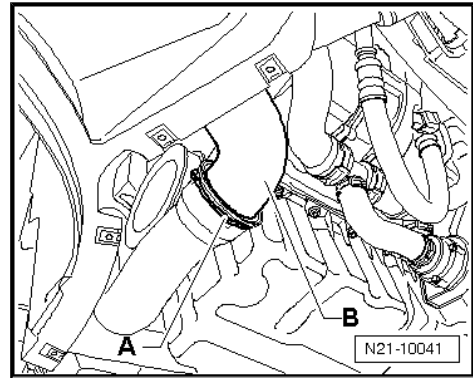

- Fit adapter -V.A.G 1687/5- onto charge air hose -A- and turn adapter through approx. 90° -B-.

Prepare charge air system tester -V.A.G 1687- as follows:

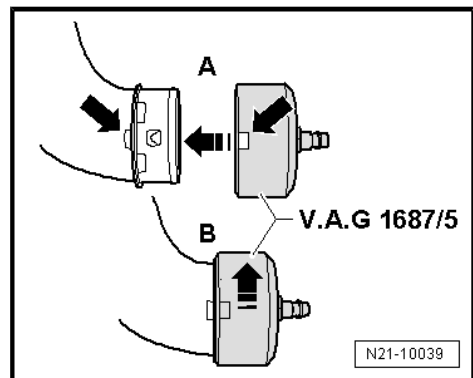

- Unscrew pressure control valve -2- all the way and close valves -3- and -4-.



Note

Make sure knob is pulled out before turning pressure control valve -2-.

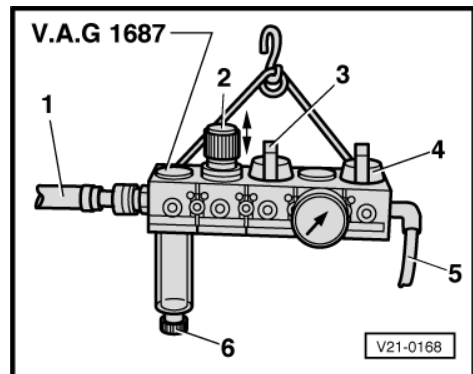

- Connect charge air system tester -V.A.G 1687- as illustrated.

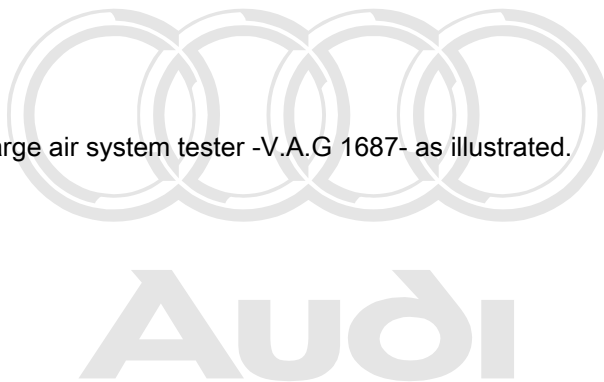
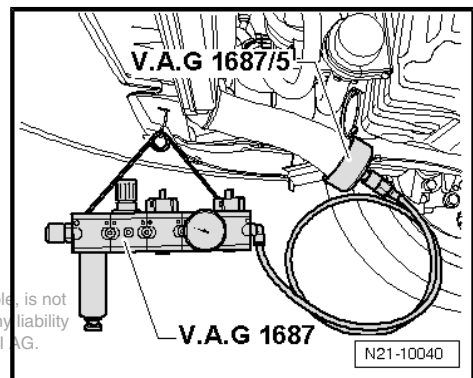

Protected by copyright. Copying for private or commercial purposes, in part or in whole, is not permitted unless authorised by AUDI AG. AUDI AG does not guarantee or accept any liability with respect to the correctness of information in this document. Copyright by AUDI AG.

- Connect pressure hose -1- (compressed air supply line) to charge air system tester -V.A.G 1687- .

 **Note**

If sight glass contains water, loosen drain plug and drain water -6-.

- Open valve -3-.
- Adjust pressure to 0.5 bar via pressure control valve -2-.



Caution

The pressure must not exceed 0.5 bar. If the pressure is set too high this can damage the engine.

- Open valve -4- and wait until test system is pressurised. Re-adjust pressure to 0.5 bar if necessary.
- Check charge air system for visible or audible leaks and apply commercially available leak detecting spray or use ultrasonic tester -V.A.G 1842- .

 **Note**

- ◆ *A small amount of air escapes through the valves and enters the engine. Therefore it is not possible to perform a pressure retention test.*
 - ◆ *Operation of ultrasonic tester -V.A.G 1842- → Operating instructions .*
 - ◆ *Release pressure by detaching coupling from adapter -V.A.G 1687/5- before removing adapter.*
 - ◆ *Hose connections and hoses for charge air system must be free of oil and grease before assembly.*
- Installing air pipes with connectors ⇒ [page 164](#)

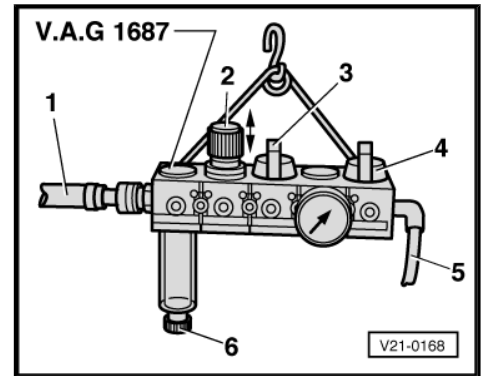

Audi

Protected by copyright. Copying for private or commercial purposes, in part or in whole, is not permitted unless authorised by AUDI AG. AUDI AG does not guarantee or accept any liability with respect to the correctness of information in this document. Copyright by AUDI AG.

26 – Exhaust system

1 Parts of exhaust system



Note

- ◆ To avoid any damage, the flexible joint in the front exhaust pipe must not be bent more than 10°.
- ◆ Renew gaskets and self-locking nuts.
- ◆ After working on the exhaust system, ensure that the system is not under stress and that it has sufficient clearance from the body. If necessary, loosen clamp and align silencers and exhaust pipe so that sufficient clearance is maintained to the body at all points and the mountings are evenly loaded.
- ◆ The exhaust manifold and the turbocharger are one component; removing and installing ⇒ [page 164](#)

1.1 Exhaust system - exploded view

1 - Bolt

- 23 Nm

2 - Bracket for exhaust system

3 - Clamp

- Align exhaust system so it is free of stress before tightening clamp ⇒ [page 194](#)
- Installation position ⇒ [page 191](#)
- Tighten bolt connections evenly.

4 - Nut

- 23 Nm

5 - Bracket for exhaust system

6 - Rubber mounting

- Renew if damaged

7 - Rubber mounting

- Renew if damaged

8 - Mounting

- Renew if damaged

9 - Bolt

- 23 Nm

10 - Tunnel brace

11 - Gasket

- Renew

12 - Nut

- 40 Nm

- Renew

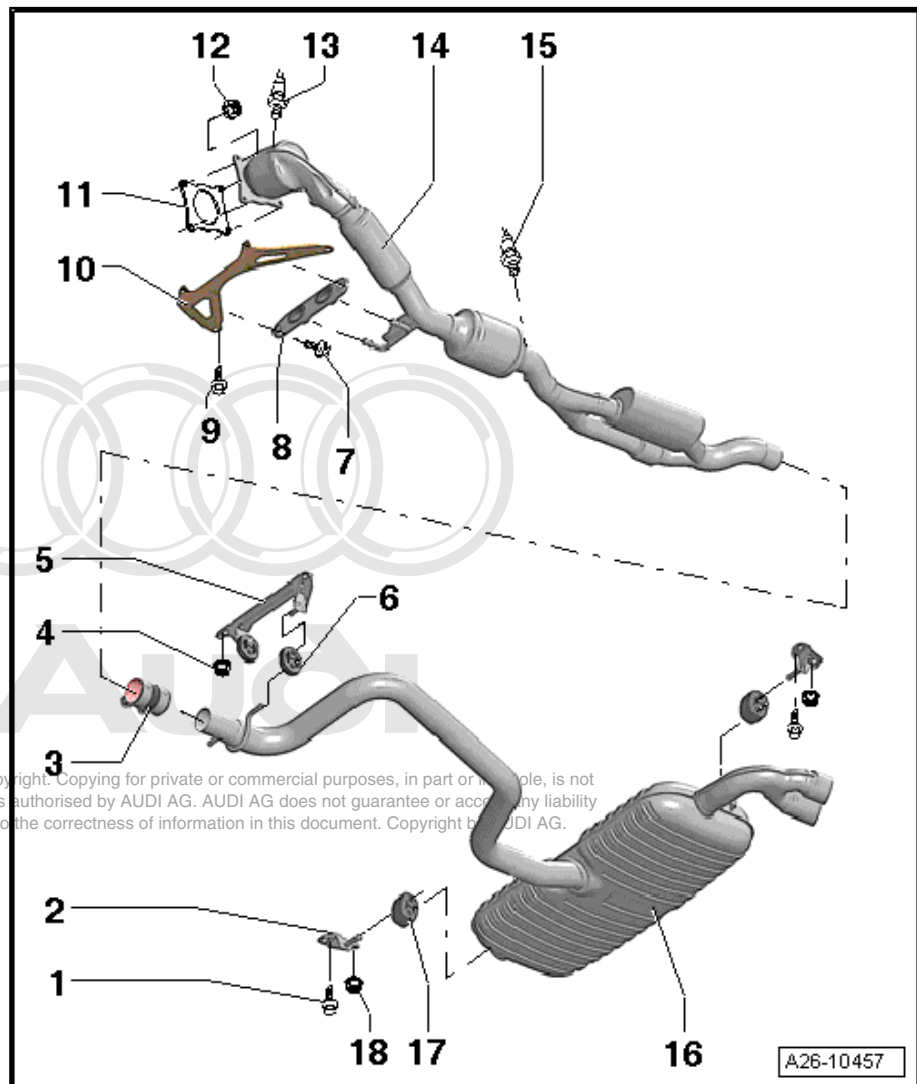

Copyright © Audi AG. Copying for private or commercial purposes, in part or in whole, is not permitted unless authorised by AUDI AG. AUDI AG does not guarantee or accept any liability with respect to the correctness of information in this document. Copyright by AUDI AG.

- Coat studs of turbocharger with high-temperature paste
- High-temperature paste ⇒ Parts catalogue

13 - Lambda probe -G39- and Lambda probe heater -Z19-

- 55 Nm
- Grease only the threads with high-temperature paste. The paste must not penetrate into the slots on the probe body.
- High-temperature paste ⇒ Parts catalogue
- Removing and installing ⇒ Rep. Gr. 24

14 - Front exhaust pipe with catalytic converters and front silencer

- Do not bend flexible joint more than 10° - otherwise it can be damaged
- Install flexible joint so that it is not under tension.
- Take care not to damage wire mesh on flexible joint.
- Protect catalytic converter from damage by knocks and impact
- Removing and installing ⇒ [page 191](#)
- Align exhaust system so it is free of stress ⇒ [page 194](#)

15 - Lambda probe after catalytic converter -G130- and Lambda probe heater 1 after catalytic converter -Z29-

- 55 Nm
- Grease only the threads with high-temperature paste. The paste must not penetrate into the slots on the probe body.
- High-temperature paste ⇒ Parts catalogue
- Removing and installing ⇒ Rep. Gr. 24

16 - Rear silencer

- Align exhaust system so it is free of stress ⇒ [page 194](#)

17 - Rubber mounting

- Renew if damaged

18 - Nut

- 23 Nm

Installation position of clamp

- Position clamp at angle shown when installing.
- Bolt connections face to right.
- Nuts face upwards.
- $\alpha = \text{approx. } 20^\circ$

Protected by copyright. Copying for private or commercial purposes, in part or in whole is not permitted unless authorised by AUDI AG. AUDI AG does not guarantee or accept any liability with respect to the correctness of information in this document. Copyright by AUDI AG.

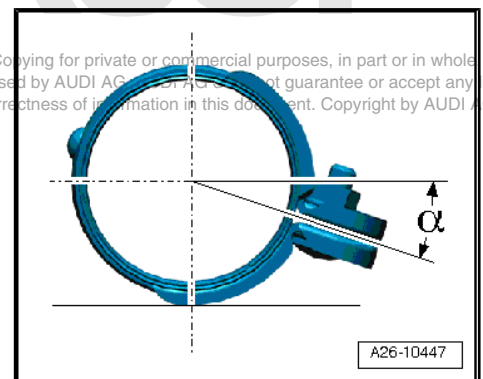

1.2 Removing and installing front exhaust pipe with catalytic converters and front silencer

Special tools and workshop equipment required



◆ Lambda probe open ring spanner set -3337-

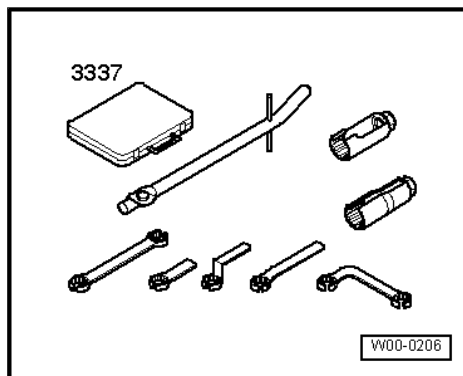

Removing

- Unplug electrical connector at air mass meter -G70- -3-.
- Open clamps -1 and 2- and disconnect air intake hose from air mass meter.
- Detach air intake connection at lock carrier -4-.
- Pull off engine cover panel.

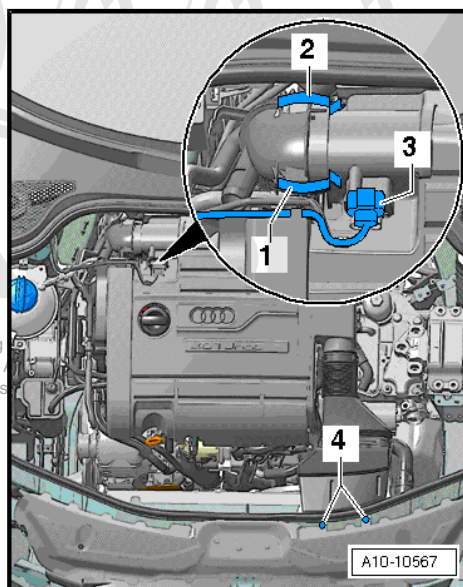

Protected by copyright. Copying or reproduction is permitted unless authorised by Audi AG with respect to the correctness.

- Unplug electrical connector -arrow- for Lambda probe -G39- and Lambda probe heater -Z19- and move wiring clear.

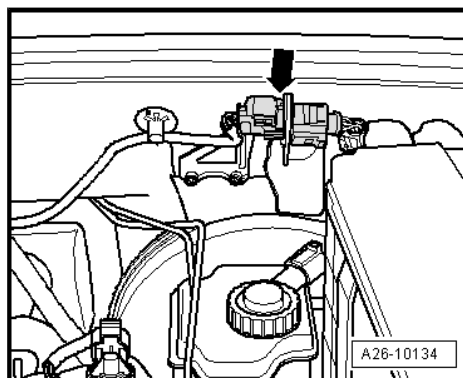

- Unscrew Lambda probe -G39- -arrow- using tool from Lambda probe open ring spanner set -3337- .

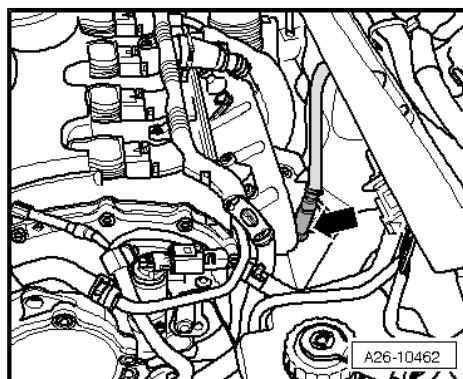

- Unscrew securing nuts -arrows- of front exhaust pipe/turbo-charger accessible from above.

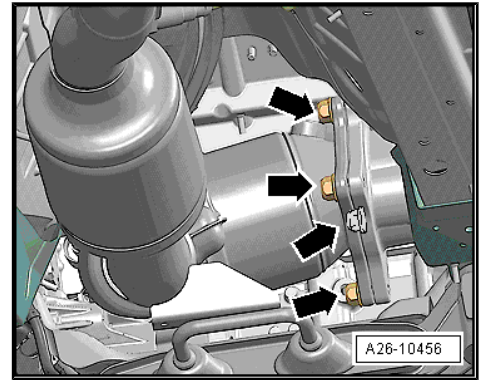

- Remove nuts -1- and -2- on bracket for electrical connector for Lambda probe on underside of vehicle and remove cover.
- Unscrew bolt -3- and move electrical wire for Lambda probe clear.

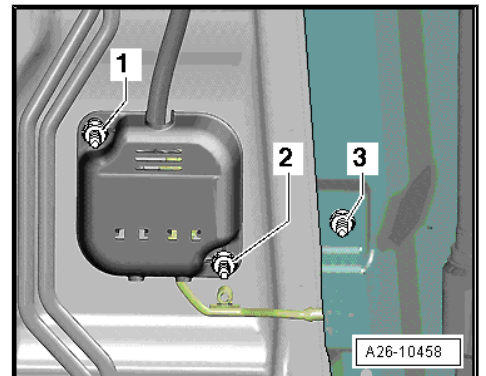

- Detach plug connector from bracket -arrow-.
- Unplug connector for Lambda probe after catalytic converter -G130- .

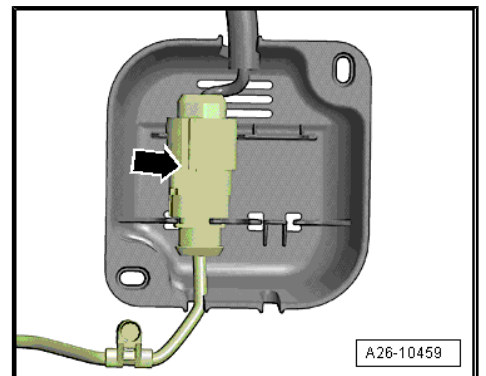

- Unscrew remaining securing nuts -arrows- for front exhaust pipe/turbocharger from below.

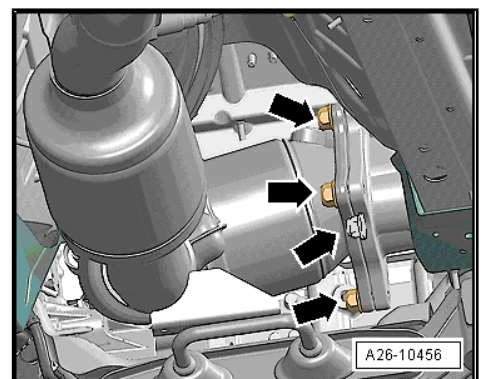

Protected by copyright. Copying for private or commercial purposes, in part or in whole, is not permitted unless authorised by AUDI AG. AUDI AG does not guarantee or accept any liability with respect to the correctness of information in this document. Copyright by AUDI AG.

- Unbolt bracket for exhaust system and tunnel brace -arrows-.

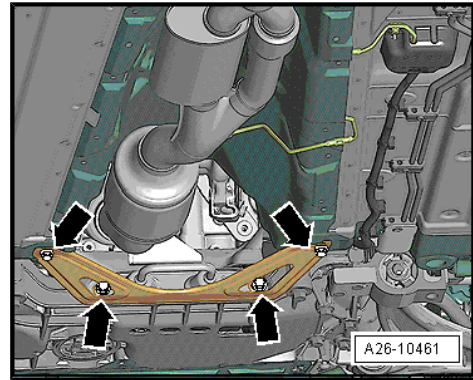
**Note**

To avoid any damage, the flexible joint in the front exhaust pipe must not be bent more than 10°.

- Separate exhaust system at clamp -arrows-.
- Remove front exhaust pipe with catalytic converter and front silencer.

Installing

Installation is carried out in the reverse order; note the following:

- Tightening torques ⇒ [page 190](#)

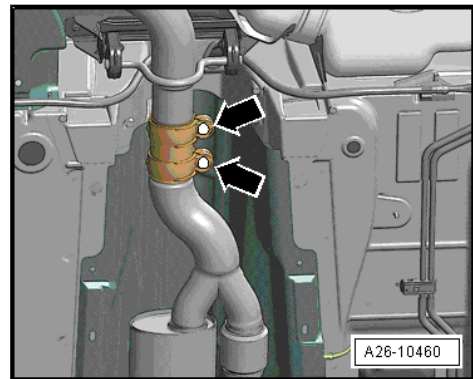
**Note**

Renew gaskets and self-locking nuts.

- Align the exhaust system so it is free of stress ⇒ [page 194](#).

1.3 Aligning exhaust system

- The exhaust system must be aligned when it is cool.
- Tightening torques ⇒ [page 190](#)
- Loosen bolt connections of front clamp ⇒ [Item 3 \(page 190\)](#).
- Push rear silencer towards front of vehicle -arrow-, so that rubber mounting (left-side) is preloaded by dimension -a- = 11 ... 13 mm.

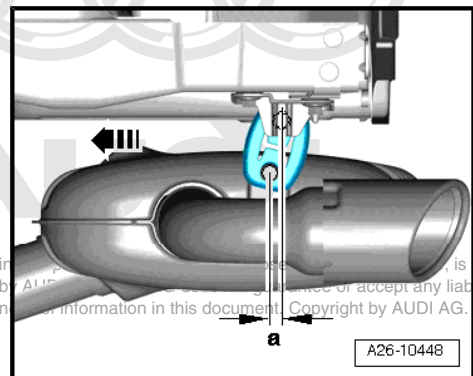

Protected by copyright. Copying or reproduction in any form is not permitted unless authorised by AUDI AG. No warranty is given or accepted any liability with respect to the correctness of the information in this document. Copyright by AUDI AG.

- Position clamp at angle shown when installing.
- Bolt connections face to right.
- Nuts face upwards.
- $\alpha = \text{approx. } 20^\circ$
-
- Tighten bolt connections on clamp evenly.

Aligning tailpipe:

- Align tailpipes so that distance -a- is the same on both sides.
- At the same time, distance -b- must be obtained between bumper cut-out and top of tailpipes.
- ◆ Dimension b = min. 21 mm
- If necessary, unfasten rear silencer mounting to align tailpipes.

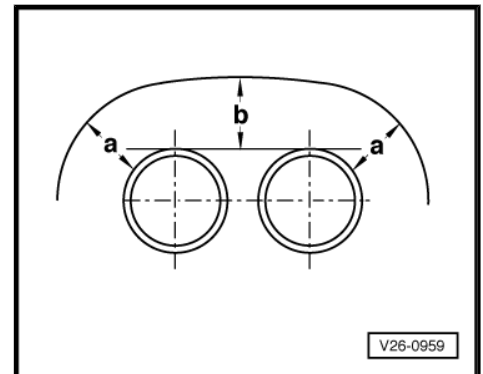
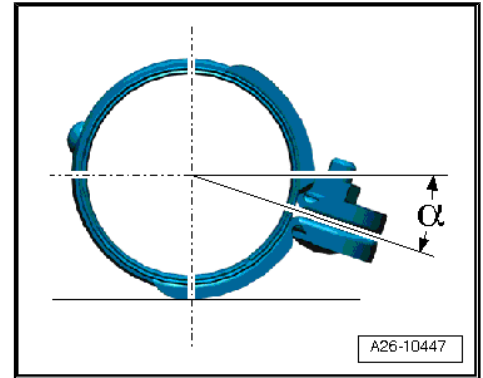

1.4 Checking exhaust system for leaks

- Start engine and run at idling speed.
- Plug the tailpipe (e. g. with rags or stopper) and leave plugged until the check is complete.
- Listen for noise at connection points (cylinder head/exhaust manifold, exhaust manifold/front exhaust pipe, etc.) to locate any leaks.
- Rectify any leaks that are found.

Audi

Protected by copyright. Copying for private or commercial purposes, in part or in whole, is not permitted unless authorised by AUDI AG. AUDI AG does not guarantee or accept any liability with respect to the correctness of information in this document. Copyright by AUDI AG.